



26.1 SCOPE.

26.1.1 Purpose. This section establishes the rules and practices related to preparing, annotating, revising, and using 3D solid model data sets and axonometric drawing views as deliverables in accordance with ASME Y14.41-2003 “Digital Product Definition Data Practices” and MIL-DTL-31000C. Some material in this section was developed specifically for the DRM. ASME Y14.41-2003 builds upon other ASME Y14 series standards, in some cases creating additional requirements, and in other cases taking exception with the other standards.

26.1.2 Introduction. Solid models. CAD data. Digital data representing three-dimensional (3D) solid models. Digital product definition data sets. These are all terms for the digital representation of the solid model data used to define and describe mechanical parts and assemblies so common in industry today. Indeed, over the last twenty-five years the use of 3D CAD solid models has been increasing at a rapid pace.

Today, most companies design their products using CAD software which has the ability to design the product as a 3D solid model. Whereas past practices limited the engineer to design and describe the product using two-dimensional (2D) representations and orthographic views, modern CAD software allows the design engineer to model the product as a three-dimensional (3D) entity. This single advancement vastly improves the quality of the design and enhancing the ability of all involved to visualize and understand the product.

Perhaps one of the first benefits recognized from using 3D CAD software was associativity of geometric definition of the product in orthographic views on a drawing. The lines, circles, curves etc, in each view were linked to and derived from the same data, the 3D solid model. Any geometric change to the 3D solid model automatically manifested itself in the various views on the drawing. This was a dramatic improvement of the earlier 2D method of CAD and manual drafting where the geometric product definition in each view was not-associated with the other views; each view was independent from the other views on the drawing. The drafter had to be careful and manually ensure that any change to the model was correctly reflected in all affected drawing views. Basing all the drawing views on a common 3D model ensured that the geometry in the views would remain synchronized, regardless of the changes made to the model. Knowing this, the design engineer no longer had to spend valuable time manipulating the view geometry to ensure agreement between the views – this time could now be spent on other more beneficial tasks.

The next benefit was recognizing that once a solid model is created, it is very easy to create a pictorial (axonometric, isometric, oblique, etc.) view of the product. The design engineer could create a pictorial view virtually for free, and this view could be easily added to the drawing. This improves the usefulness of the drawing by making it easier for everyone to “see” the product in 3D. This led to a huge improvement in drawing clarity, as many people have difficulty understanding drawings based on orthographic projection alone. (For the purposes of this section, further discussion of pictorial views will focus on axonometric views.) Today, most product drawings created by companies using 3D CAD software include one or more axonometric views.

Further benefits of designing in 3D were made available as the software vendors developed new tools for using the 3D solid model data for other purposes, such as various types of analysis, mass and balance calculations, and determination of bulk product usage, such as necessary quantities of paint or adhesive to name a few. The role of the design engineer expanded with these newfound capabilities. In some cases, the time it took to complete a design was compressed, as the tools made it easier to do the same amount of work in less time. In most cases, however, the amount of work done during the design process increased, as the design engineer was now able to do more using the same data set. More “what if” scenarios were contemplated. More analyses were performed, some “on the fly”, as it was now relatively easy to get estimates of critical performance characteristics. However, perhaps the most important benefit from designing in 3D came when downstream processes began to use the 3D model data.

Much of modern Computerized Numerical Control (CNC) processing machinery is incredibly precise, and is essentially driven by 3D coordinate data. Early on this 3D coordinate data was fed manually into these machines. A programmer would enter the data manually into the machine using a 2D drawing as the source of the part geometry. The programmer would define one or more coordinate systems on the part, convert the



dimensional data on the drawing to the format needed for entry into the CNC machine's interface or control software, and then would assign process information to complete the programming. Obviously, a lot of manual data entry was required. There was a chance of error, as the programmer essentially duplicated and converted the drawing data into a form that worked with the machinery and its programs. As CAD tools increased in sophistication, software was developed to export the 3D model data, allowing the CNC programmer to use the CAD geometry instead of having to manually enter the data. When these capabilities were expanded to use 3D solid model data, manufacturing saw tremendous benefits. Their risk of making mistakes was reduced, as they no longer had to duplicate the part data on the drawing, and their productivity increased, as they no longer had to spend the time required for conversion.

Soon the use of the 3D solid model data moved into the quality and inspection areas. The Coordinate Measuring Machine (CMM) was developed to make use of the 3D solid model data during inspection, and with its advent the same data could now be used in design, analysis, manufacturing and inspection. The cycle was complete; by using the same data throughout the product development process productivity was increased, cycle time was reduced, and probability of errors was reduced.

Today, 3D solid model data is ubiquitous. 3D solid models may be found in most companies, and are used by many departments and by suppliers and vendors. The 3D solid model data has in many cases become the design master, the primary representation of the part or assembly geometry. This ubiquity brings with it a need to carefully control the model. Companies have long understood the need to control drawings, as a drawing is the legal document which defines the majority of requirements for a given part or assembly. Companies that use 3D solid models have also learned that the 3D solid model data is equally important, plays an even more important role in its many uses, and that like drawings, the 3D solid model data must be formally controlled.

Product Data Management (PDM) systems are used to manage the many computer files and data sets produced by the various departments within a company or entity. Sophisticated PDM programs are used to coordinate and manage related files for a given product for all departments. As the use of the 3D solid model data has become more varied and sophisticated, the software tools needed to manage the many uses of the data have also become more sophisticated.

The logical conclusion reached by some companies to the increasing role of the 3D solid model data is a desire to eventually eliminate the need for a paper drawing altogether. That is, the goal is to use the 3D solid model data set as the design deliverable, and to package and format the data in such a way that everyone who has historically needed to use the drawing will be able to obtain the needed information from the digital 3D data set. This process is not without problems, as a painstaking process must be undertaken to ensure that each user can indeed get the information they need to do their job. And, this information must also be easy to use. For this transformation to a purely digital domain to make business sense, it must leave us with higher quality, faster throughput, and reduced cost. The verdict is still out on this.

Finally, as the use of 3D solid model data has increased to its present level, it has become clear to all involved that it is essential for 3D solid model data sets to follow common sets of rules for format, content, data display, annotation, etc. Just as rules for drawing format and content are needed, it has become apparent that rules for model format and content are also required. Engineering drawing standards have been around for a long time. ASME has produced the Y14 series of standards for many years. With these considerations in mind, ASME introduced the ASME Y14.41-2003 "Digital Product Definition and Data Practices" standard in 2003. This standard covers 3D solid model data set creation, formatting and revision. The remainder of this section presents the rules and techniques defined in this standard.

26.1.3 Using and Annotating Axonometric Views. ASME Y14.41 allows using axonometric views on drawings, and establishes rules for annotating axonometric views, both on the model and on the drawing. This practice is not explicitly prohibited by other ASME Y14 standards, it just isn't discussed. Allowing dimensions and tolerances and other annotation to be placed on axonometric views offers additional tools and techniques to more clearly and concisely define the design requirements. However, this practice also brings new challenges, as some of the existing annotation tools and techniques defined for drawings based on orthographic projection do not work with axonometric views or with annotated models that may be rotated. For example, some of the



dimensioning and tolerancing techniques described in ASME Y14.5 are view-specific; they are only suited for use with orthographic views. ASME Y14.41 addresses these limitations and provides new techniques for annotating axonometric views and models. The rules governing the use of axonometric views and the new annotation tools will be explained in this section.

26.2 Invocation of ASME Y14.41-2003. A note must be added to the data set or a document referenced in the data set for the ASME Y14.41-2003 standard and all of its provisions to apply to the data set. If the Y14.41-2003 standard is not formally referenced in the data set as described in the previous sentence, then the standard does not apply. The standard may be referenced on a drawing in the data set, in or on an annotated model in the data set, on a document in or referenced by the data set, or any combination thereof.

26.3 APPLICABLE DOCUMENTS. Note: DoD Policy Memo 05-3 “Elimination of Waivers to Cite Military Specifications and Standards in Solicitation and Contracts” has eliminated the need for waivers to use MIL-SPECS and MIL-STDS on DoD contracts. (See PREFACE 1, Section 2)

ASME Y14.1/1M	Decimal Inch Drawing Sheet Size and Format
ASME Y14.2M	Line Conventions and Lettering
ASME Y14.3M	Multiview and Sectional View Drawings
ASME Y14.4M	Pictorial Drawings
ASME Y14.5M-1994	Dimensioning and Tolerancing
ASME Y14.8M	Castings and Forgings
ASME Y14.35M	Revision of Engineering Drawings and Associated Documents
ASME Y14.38M	Abbreviations and Acronyms
ASME Y14.41-2003	Digital Product Definition Data Practices
ASME Y14.100	Engineering Drawing Practices
IEEE / ASTM SI 10	Standard for Use of the International System of Units (SI)
ISO 16792	Technical Product Documentation – Digital Product Definition Data Practices (This standard was based on and derived from ASME Y14.41-2003.)
ISO 10303-1	Industrial Automation Systems and Integration – Product Data Representation and Exchange: Part 1: Overview and Fundamental Principles (STEP)

26.4 Definitions.

26.4.1 Annotation. Dimensions, tolerances, notes, text, or symbols visible without any manual or external manipulation.

26.4.2 Annotation Plane. A conceptual plane containing annotation that either perpendicularly intersects, or is coincident with one or more surfaces of a feature.

26.4.3 Assembly Model. A model in which the product described is an assembly of two or more items.

26.4.4 Associated Entities. The portion of a product definition to which annotation pertains.

26.4.5 Associated Group. A user-defined set of related digital elements.

26.4.6 Associativity. The established relationship between digital elements.

26.4.7 Attribute. A dimension, tolerance, note, text, or symbol required to complete the product definition or feature of the product that is not visible but available upon interrogating the model.



26.4.8 Data. Information represented in a formal manner suitable for communication, interpretation, or processing by human beings or computers.

26.4.9 Datum System. A partial or complete datum reference frame. (Note: For the purposes of this document, the term “datum system” shall not be used, as it is synonymous with the term *datum reference frame* previously established in ASME Y14.5M-1994 and earlier revisions of that standard.)

26.4.10 Datum Reference Frame. A Cartesian coordinate system consisting of three mutually perpendicular axes (or planes) derived from the theoretically perfect mathematical representation of specified datum features. Datum reference frames are defined by specifying datum features on drawings (or models in the case of this section and ASME Y14.41-2003), simulating those datum features using the appropriate true geometric counterparts (or datum feature simulators), and relating the datum reference frame to the specified datum features.

26.4.11 Derivative. Data duplicated or extracted from the original (or design master). A copy of a derivative is also a derivative.

26.4.12 Design Master. The data set that is considered to be the master representation of the design data. This may be a hard copy drawing; it may be a digital CAD data set representing the 2D drawing; or it may be an annotated 2D or 3D CAD solid model data set. This is similar to the concept of the “original” drawing as defined in ASME Y14.100. The term “design master” is unique to this section and is not part of ASME Y14.41.

Note: The term “original” is defined in ASME Y14.100, and refers to “the current design activity’s drawing on which the official revision record is kept.” That same concept is used here as the design master, and expanded to include digital drawing data sets and annotated 3D CAD data sets.

26.4.13 Design Model. The portion of the data set that contains model and supplemental geometry.

26.4.14 Digital Element. A geometric element, feature, group of features, annotation, associated group, or attribute that exists in a data set.

26.4.15 Digital Element Identifier. A label or name used to specify a unique digital element.

26.4.16 Direction Dependent Tolerance. A tolerance that invokes a zone of parallel lines or curves.

26.4.17 Geometric Element. A graphic entity used in a data set. For example, point, line, plane, surface, solid, model coordinate system, or crosshatching.

26.4.18 Hard Copy. A printed or plotted copy of a displayed image on a medium such as paper or polyester film.

26.4.19 Installation Model. A model in which the product described is an installation, showing parts or assemblies and a partial or complete representation of the installation site.

26.4.20 Management Data. The data required for the release, control, and storage of product definition data as well as other relevant engineering data.

26.4.21 Model. A combination of design model, annotation and attributes that describes a product.

26.4.22 Model Coordinate System. A representation of a Cartesian coordinate system in a product definition data set.

26.4.23 Model Geometry. Geometric elements in product definition data which represent designed product.

26.4.24 Model Value. The numerical value derived by interrogating the model that quantifies the form and spatial relationships of the geometry composing a design model or assembly of models to the precision (number of decimal places) of the computer system.



26.4.25 Product Definition Data. Data elements required to completely define a product.

26.4.26 Product Definition Data Set. A collection of one or more computer file(s) that discloses (directly or by reference), by means of graphic or textual presentations, or combinations of both, the physical and functional requirements of an item.

26.4.27 Query. A means of interrogating a digital element or the relationship between digital elements. (Note: see the more detailed definition and explanation for query in paragraphs 26.19.4.7 and 26.19.4.7.1.)

26.4.28 Represented Line Element. A supplemental geometry line or curve segment indicating the orientation of a direction dependent tolerance.

26.4.29 Resolved Dimension. A model value that is rounded off to the number of decimal places required for the design.

26.4.30 Saved View. A stored and retrievable specific orientation and a magnification factor of a model.

26.4.31 Special Character. A character not included in the set of letters A-Z, a-z, numerals, and punctuation symbols.

26.4.32 Supplemental Geometry. Geometric elements included in product definition data to communicate design requirements but not intended to represent a portion of the manufactured product.

(Note: Definitions 26.4.1 – 26.4.9, 26.4.11, and 26.4.13 – 26.4.32 are reprinted from ASME Y14.41-2003, by permission of The American Society of Mechanical Engineers. All rights reserved.)

26.5 Additional Concepts and Terms. ASME Y14.41 includes many new terms (or jargon), most of which are formally defined and listed in paragraph 26.4 above. There are a few additional terms that are not included in the definitions, but are unique or specific in how they are used in the standard. Definitions for these terms are included here.

26.5.1 Feature. ASME Y14.41 uses the term “feature” differently than it is used in ASME Y14.5M-1994. In ASME Y14.41 the term “feature” refers to the digital representation of a feature in a model or on a drawing. In ASME Y14.5M-1994, “feature” refers to an actual physical feature of a part. Where necessary, distinction between these usages will be made clear in this section.

26.5.2 Integral. Incorporated in and inseparable from the data set. Refers to data elements which are part of the data set.

26.5.3 Related Data. Data that is required to complete product definition but is not necessarily integral to the product definition data set. Related data may be considered as ancillary information required to complete product definition, including analytical data, testing requirements, parts lists, material specifications, process and finish requirements. For example, a particular model data set may contain all information except various external analytical and test data. This analytical and test data may be stored in a separate location, and therefore is not integral to the model data set, but is needed to complete the product definition.

26.5.4 Associative Dimension. A dimension with a value that is derived from and directly linked to the model geometry from which it is derived. An associative dimension automatically displays or returns upon query the model value from which it is derived, and automatically updates if the model geometry is modified. For example, if the size of a hole is dimensioned with an associative dimension, and the hole size in the model is changed from Ø25mm to Ø28mm, the displayed dimension value will automatically update to Ø28mm.

26.5.5 Axonometric View. An axonometric view is a pictorial view with the surfaces of the object being viewed at an angle to the viewing plane. FIGURE 26-1 shows examples of axonometric views. Axonometric projection is defined in ASME Y14.4 Pictorial Drawing. One of the most important aspects of ASME Y14.41 is that it defines the rules for and allows applying annotation to axonometric views on models and drawings – prior ASME standards only addressed views on drawings and annotating orthographic views on drawings.

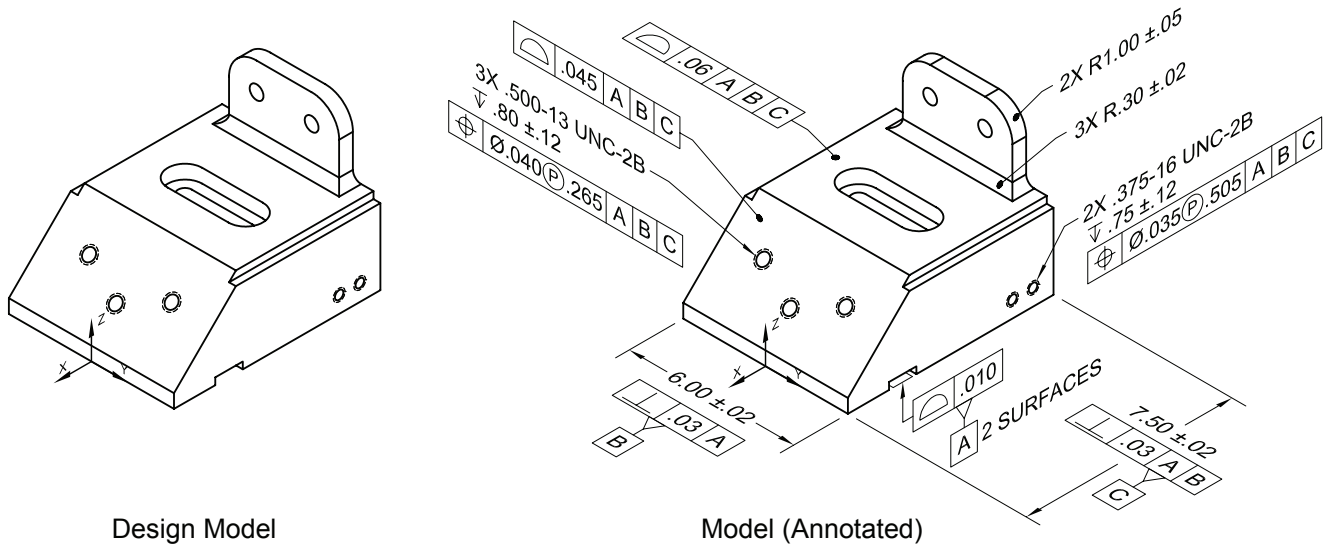

AXONOMETRIC VIEWS
 FIGURE 26-1

26.6 Units. ASME Y14.41-2003 was written using the International System of Units (SI). The standard and this section also apply to designs based on U.S. Customary Units. The primary system of units used for the design shall be specified in the data set. It is acceptable to use a different system of units to define features in a model. For example, there may be cases where metric threaded holes are needed on a part modeled using inches. In such a case, the primary units would be noted, and the exceptional features would be indicated by a note, a thread specification, or by other means. SI and U.S. Customary Units are used in this section of the DRM.

26.6.1 Specification of All Types of Units. All units needed to define the design model and completely represent its functional requirements must be clearly specified within the data set. This includes units of length, mass, temperature, pressure, etc.

26.7 History of Design Deliverables. Historically the primary design deliverable has been the engineering drawing, augmented by various other lists, printed on paper or other physical media. These documents defined the design requirements, were considered as the original or master record of the design, and presented the legal definition of these requirements. Historically these deliverables were presented as hard-copy documents. With the advent of computers and CAD software came the ability to define, store, transmit, and receive these documents electronically. In some cases, even when electronic means are used to define, store, transmit, and receive the engineering data, the design deliverable has historically been the printed copy of the design documentation. In other cases the computer-generated digital drawing files and associated documents were considered as the original or master design deliverable. Lastly, with the advent of the ability to send 3D CAD data set geometry directly to downstream processes, in some cases, these digital CAD data sets have become the design deliverable, considered as the original or master design deliverable.

26.8 The Design Master. The portion of the data set to be used as the design master must be clearly defined within the product definition. Of primary concern is which data set should be used as the primary source of dimensional data, and which source takes precedence in case of a conflict between potential sources. Options for the design master are discussed in the following paragraph.

26.8.1 Options for the Design Master. There are three choices for which data set may be considered as or designated as the design master:

1. The hard-copy drawing (or hard copy)
 - a. This is a representation of the drawing printed on physical media such as paper, vellum, etc.



- b. This may be a manually-generated drawing or a printed or plotted copy of a computer-generated (CAD) drawing.
 2. The digital CAD drawing file
 - a. This is the digital CAD drawing file, not the hard-copy version. This is a two-dimensional (2D) CAD drawing.
 - b. This digital CAD drawing may be derived from a 3D model, it may be a 2D CAD drawing not supported by a 3D model, or it may be a raster-scan or other copy of a drawing originally created manually or by other means.
 3. The annotated CAD model (or model)
 - a. This is a completely digital data set which contains the full product documentation.
 - b. This is not necessarily a traditional drawing with border, title block, etc. It may just be a digital 2D or 3D CAD model file with all the required information associated.

ASME Y14.41 does not address manually-prepared drawings, as they are adequately addressed by other standards in the Y14 series. The remaining choices for original are the hard copy of a CAD drawing, the digital CAD drawing file, the 2D or 3D CAD model geometry, or an annotated 2D or 3D CAD model.

With these choices comes the potential for confusion, as there are several options for what should be considered as the master or original design deliverable within the data set. So it is critical that it is clear which version or representation of the design is to be considered as the design master. This is especially important in environments where multiple versions or representations of a design are delivered to downstream processes. For example, consider the case where the 3D CAD model and the drawing generated from the CAD model are sent to the manufacturer. There will likely be discrepancies between these two data sets (from rounding of decimal places, etc.) – it is critical that the recipient understands clearly which of these two potentially conflicting data sets is the master and which is subordinate in cases of conflict between the two. Typically the conflict arises in dealing with dimensional values.

Note: ASME Y14.41 does not address this potential discrepancy directly, but instead requires the model data and the drawing data to be in agreement. The standard mandates that resolved dimensions shall be in agreement with model values, meaning that the dimension values obtained by querying the model, dimensioned directly on the model, or displayed on a drawing made from the model shall be derived from and in mathematical agreement with the model. The only allowable differences are as follows:

- From rounding the actual model value to a given number of decimal places displayed in a dimension or query value.
- With limit dimensions, the resolved model value may be equal to either limit or any value within the specified limits.

To be in compliance with ASME Y14.41, agreement and associativity between the model values and resolved dimension values must be maintained. In cases where the deliverable consists of multiple data set formats, such as a model and a drawing, it is still a good idea to formally state which data set is the master for a particular piece of information, such as dimensional data. For example, if a model and a drawing are to be the design deliverable, a note should be added to the drawing stating that dimensions not shown on the drawing are to be obtained from the model. Examples of this technique are shown throughout this section.

26.8.2 Designation of the Design Master. It must be stated clearly on the design deliverable(s) or in the project documentation which representation of the design is to be considered as the design master. As stated above, this is especially critical in cases where more than one representation of the design is transmitted to downstream activities, such as manufacturing, inspection, and assembly. In such cases it is a good idea to include this designation on all of the design deliverables, stating clearly which of the deliverables is to be used as the design master. Sample notations follow:



On the Hard-Copy Drawing:

THIS HARD-COPY DRAWING IS THE DESIGN MASTER. THE INFORMATION ON THIS DOCUMENT SHALL TAKE PRECEDENCE IN ANY CASE OF CONFLICT BETWEEN THIS DOCUMENT AND OTHER DESIGN DELIVERABLES.

On the Digital CAD Drawing File:

THIS DRAWING IS THE DESIGN MASTER. THE INFORMATION ON THIS DOCUMENT SHALL TAKE PRECEDENCE IN ANY CASE OF CONFLICT BETWEEN THIS DOCUMENT AND OTHER DESIGN DELIVERABLES.

On the Model:

THIS MODEL IS THE DESIGN MASTER. THE INFORMATION IN THIS MODEL SHALL TAKE PRECEDENCE IN ANY CASE OF CONFLICT BETWEEN THIS MODEL AND OTHER DESIGN DELIVERABLES.

In a Data set File for a File Referenced in the Data set:

THE (HARD COPY DRAWING, DIGITAL DRAWING, MODEL) IS THE DESIGN MASTER. THE INFORMATION IN THIS MODEL SHALL TAKE PRECEDENCE IN ANY CASE OF CONFLICT BETWEEN THIS MODEL AND OTHER DESIGN DELIVERABLES.

The model, hard copy drawing, digital drawing, or model must be selected when using this method.

By stating which design deliverable is the master, all other forms of the data are to be treated as derivatives of the master. This clarifies that any redundant or conflicting information on other design deliverables is to be considered as derived from and superseded by the master. This thinking is inherent in the logic of ASME Y14.41. It is expanded here with the hopes of offering another line of defense against misunderstanding or misinterpretation of potentially conflicting design data. Ultimately there must be a single definition for all specifications.

26.9 Differences Between ASME Y14.41 and other ASME Y14 Series Standards. During the development of ASME Y14.41 it was noted that certain techniques, rules, and tools from existing ASME Y14 series standards were not appropriate for use with axonometric views and annotated models. Models are not static like views on a drawing, and may be rotated while viewing, thus a new set of challenges arose to guarantee specifications were legible and unambiguous. For example, some of the dimensioning and tolerancing techniques described in ASME Y14.5 are view-specific, and they are only suited for use with orthographic views. ASME Y14.41 addresses these limitations and provides new techniques for annotating axonometric views and models.

26.10 Rules for Data Sets. ASME Y14.41 includes rules and guidelines for properly formatting and managing data sets and the data within the data set as described in the following sub-paragraphs.

26.10.1 Data Set Identification and Management Requirements. Data sets must be properly identified and their revision must be properly specified.

26.10.2 Data Set Identification. Data sets shall be identified using a unique alpha-numeric data set identifier that may not contain any spaces between characters. In cases where the part or identifying number (PIN) is used as the data set identifier, the data set identifier shall be in accordance with rules prescribed in ASME Y14.100 and paragraph 11.3.16. It is generally accepted that the data set identifier, including any prefixes and suffixes, should not exceed 32 characters in length. This limitation helps ensure that the data set identifier is compatible with the various computer file and automated product data management systems.

26.10.3 Data Set Management. Data sets shall be structured and formatted in such a way that ensures they may be managed by a system that provides the means to control, track, revise, review, release, check status,



and other activities needed to work with the data set. This data management system may be a part of the CAD system itself or an external program or system.

26.10.4 Data Set Approval. Data sets shall be approved in accordance with ASME Y14.100 and as described in paragraph 2.6.13 in the DRM.

26.10.5 Data Set Storage. Data sets shall be stored throughout a product's lifecycle using a formal system that allows retrieval by authorized parties.

26.10.6 Data Set Revision. The current revision status and revision history shall be integral to the data set, and shall be managed in accordance with ASME Y14.35M and as defined in Section 23 of the DRM.

26.11 Product Definition Data Set. A product definition data set must contain all of the information necessary to completely and unambiguously define the physical and functional requirements of an item (product). The data set may be presented using a combination of graphic data and textual data in a variety of formats. This information may be included in the data set directly or through reference to the applicable source data. The data set is considered as the original and any hard-copy is considered as a derivative. See definition 26.4.26.

26.11.1 Integral and Related Data in the Data Set. All pertinent and necessary data shall be integral to or referenced in the data set.

26.11.2 Integral Product Definition Data Set Contents. The Product Definition Data Set shall include:

- The model and its subordinate data
 - Annotation
 - Design model
 - Model geometry
 - Supplemental geometry
 - Physical data
 - Material data
 - Mass properties (Optional for 3D wireframe or 2D model representations)
 - In cases where the model is not represented as a 3D solid model, e.g. if the model data only provides a wireframe or 2D representation, material data and mass properties may be included as related or supplemental data. Similar issues may exist with solid models that have been converted or exported using a translator (dumb solids). Best practice is to include a 3D solid model that includes material data and mass properties in the data set.
 - Attributes
- Revision history
- Drawing notes and / or model notes
- Data set management data

26.11.3 Related Product Definition Data Set Contents. Related data may be integral to or referenced by the product definition data set. Related data includes but is not limited to:

- Analytical data
- Test data
- Prototyping information
- Parts list(s)
- Material specifications



- Surface texture requirements
- Finish requirements
- Supplemental data
- Testing requirements
- Processing requirements
- Quality control requirements
- Data reporting requirements

26.11.4 Requirements for Model-Only Product Definition Data Sets. These requirements apply if a model is intended to provide complete product definition. The model-only data set must contain the following information either integrally or by reference:

1. Product Definition Data, including but not limited to:
 - a. Notes
 - b. Parts list(s)
 - c. Marking requirements
 - d. Dimensions and tolerances
 - e. Material(s)
 - f. Surface texture requirements
 - g. Finish requirements
2. Title Block Data Elements:
 - a. Name and address of the company or design activity corresponding to the CAGE code for the data set
 - b. Data set title
 - c. Data set number
 - d. Approval and release data
 - e. Revision data
 - f. Contract number (if required)
 - g. Name of originator and date originated
 - h. CAGE code if required for identifying the originator of the data set number

26.11.5 Requirements for Model and Drawing Product Definition Data Sets. These requirements apply if a model and drawing are intended to provide complete product definition. The model and drawing data set must contain the following information either integrally or by reference:

1. Sufficient views on the drawing or of the model to completely define the design model and its requirements. These may include orthographic views, axonometric views, or a combination of the two.
2. Annotation may be specified on the model, the drawing, or a combination of the two. Note that the drawing may provide complete product definition if desired.
3. Data that resides in the model and on the drawing must be in agreement.
4. The drawing shall be formatted in compliance with ASME Y14.1 or ASME Y14.1M as appropriate.
5. The drawing must reference all applicable models for the design depicted on the drawing.
6. Hard copy drawings derived from the data set shall meet the requirements set in ASME Y14.1, Y14.1M, Y14.2M, Y14.3M, and Y14M as applicable.
7. Annotation on the drawing shall be visibly accessible without querying the data set.



8. A note shall be added to any drawing that does not contain complete product definition.
9. A note shall be added to any model that does not contain complete product definition.

26.12 Data Set Completeness. The data set shall provide a complete definition of the product.

26.13 Fundamental Dimensioning and Tolerancing Requirements. The following fundamental dimensioning and tolerancing requirements apply to both annotated models and drawings, apply specifically to annotated models, and apply specifically to drawings as noted. (Note: The material in this section has been reprinted with the permission of the ASME – see the note at the end of this section. However, the paragraph and figure references have been revised to refer to paragraphs and figures in the DRM.)

a. Common to Annotated Models and Drawings

1. All model values and resolved dimensions shall be obtained from the model. See paragraphs 26.22 and 26.23 and FIGURE 26-32.
2. The ability to query the model shall be available. See paragraphs 26.19.4.7 and 26.19.4.7.1.
3. There is no implied 90 deg basic angle rule, as defined in ASME Y14.5M, for a model. All angular values shall be queried from the model. See paragraph 26.25. Exceptions to this are the model coordinate system(s) and planes associated with a datum reference frame(s) and orthographic views.
4. Direct tolerancing methods, as defined in ASME Y14.5M, should only be used to define the size of a feature. Geometric tolerancing is the preferred method. See paragraphs 26.26 and 26.30 and FIGURE 26-37.
5. When query is required, a notation stating the requirement for query of the model or associated data shall be added to the drawing or in the general notes.
6. Rounding requirements for resolved dimensions shall comply with paragraph 26.23.1.
7. When tolerancing features, alignment of the annotation plane to the true profile is not required.
8. Values queried from the model for any feature(s) without any tolerance or datum target specifications assigned shall be reference dimensions.
9. Legibility requirements of ASME Y14.2M shall apply when the annotation is viewed perpendicular to the annotation plane.
10. Annotation in any given annotation plane shall not overlap other annotation in the same annotation plane when the model is viewed perpendicular to the annotation plane.
11. Annotation text within any given annotation plane shall not be placed over the design model when the model is viewed perpendicular to the annotation plane.
12. Visible gaps between extension (projection) lines and geometry, as defined in ASME Y14.5M, are not required on models.

b. Applicable to Models Only

1. All annotation shall be specified in one or more annotation planes. When a CAD software does not support maintenance of annotation plane orientation relative to the model, the model only method shall not be used. See paragraph 26.19.4.3.
2. The associated entities, annotation, and attributes shall be in agreement. See paragraph 26.19.4.1.
3. Resolved dimensions created from queried model values are considered the same as values specified in ASME Y14.5M as expressed dimensions. See FIGURE 26-32.
4. The term TRUE, when used with a dimension, shall not be used on models.
5. Display of centerlines or center planes for features of size are optional.
6. To ensure the annotation is being interpreted as intended (for example the text could be upside down or backwards following rotation of the model) one of the following techniques shall be used:



- a. Ensure the reading direction is updated after rotation of a model.
 - b. Include a means of determining the correct reading direction in each annotation plane applied to a model.
 - c. When using saved views, ensure the model is orientated in the intended view direction. For example, this may be accomplished by including a means of determining the correct reading direction in the view.
7. Dimensions and tolerances may be shown to internal features without the use of a section. See FIGURES 26-33a, b and 26-34c.
- c. Applicable to Drawings Only
- 1. Dimensions, tolerances, datum specifications, and notes may be shown in true profile views and refer to visible outlines, or appear in axonometric views.
 - 2. Axonometric Views
 - a. The orientation of the annotation shall be parallel to, normal to, or coincident with the surface to which it applies.
 - b. Annotation shall not overlap other annotation.
 - c. Annotation shall not overlap the part.

(Note: Fundamental Dimensioning and Tolerancing Requirements listed in para. 26.13 are reprinted from ASME Y14.41-2003, by permission of The American Society of Mechanical Engineers. All rights reserved. However, the paragraph and figure references have been revised to refer to paragraphs and figures in the DRM.)

26.14 General Requirements for Models.

26.14.1 Associativity. The system(s) used to create and manage the data set shall allow digital elements within the data set to be associated to one another. Associated digital elements may be grouped into sets, and these sets and the interrelationship between elements must be available via query.

26.14.2 Model Coordinate System. The design model shall contain at least one model coordinate system.

26.14.2.1 Representing a Model Coordinate System. A model coordinate system may be shown as three mutually perpendicular lines each of which terminates in an arrowhead; these lines represent the X, Y, and Z axes of the coordinate system. The origin of the coordinate system shall be located at the intersection of these three lines. The positive X, Y, and Z directions shall be labeled as shown in FIGURE 26-2. Right-handed coordinate systems are the default for model coordinate systems; if a left-handed coordinate system is used, it shall be noted in the data set.

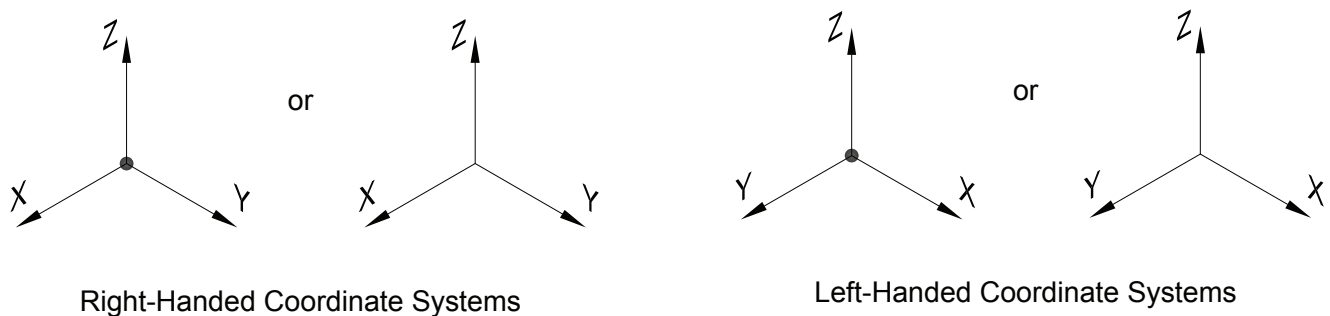

MODEL COORDINATE SYSTEM

FIGURE 26-2

26.14.3 Supplemental Geometry. Supplemental geometry is used to clarify design requirements. Supplemental geometry is not used to represent the model geometry, it is used to clarify the requirements that the as-produced part or assembly must meet.

26.14.3.1 Represented Line Elements for Geometric Tolerances. Certain geometric tolerances may be specified to apply in a particular direction. These applications are called direction dependent tolerances. The following are examples where a line element may be used to represent the direction of application for a geometric tolerance that controls line elements on a surface. The geometric tolerance feature control frame must be attached to a leader that terminates with an arrowhead on the represented line element. The represented line element, the feature control frame, and the toleranced feature must be an associated group. Note the difference between FIGURES 26-3 and 26-4. The represented line elements in FIGURE 26-3 are oriented 90° to the represented line elements in FIGURE 26-4.

- 1. Line Element Straightness.** A represented line element may be used to indicate the direction of line element straightness tolerance zones. These tolerance zones are two-dimensional, each bounded by two parallel lines. See FIGURES 26-3 & 26-4.

For the straightness tolerance in these examples, the only difference between the figures is the orientation of the represented line element. The relationship of the line element to the associated model coordinate system defines the required orientation of the straightness tolerance zones.

- 2. Orientation (Angularity, Parallelism, Perpendicularity): Each Element.** A represented line element may be used to indicate the direction of EACH ELEMENT orientation tolerance zones. These tolerance zones are two-dimensional, each bounded by two parallel lines. See FIGURES 26-3 & 26-4.

For the orientation tolerances in these examples, the difference between the figures is the orientation of the represented line element, which requires a different orientation tolerance to be specified (parallelism vs. perpendicularity). [Note: always use the orientation tolerance that corresponds to the line element's orientation to the primary datum or primary datum feature for the tolerance.] The relationship of the line element to the model coordinate system associated to the referenced datum reference frame defines the required orientation of the EACH ELEMENT tolerance zones.

- 3. Profile of a Line.** A represented line element may be used to indicate the direction of profile of a line tolerance zones. Each of these tolerance zones is an area bounded by two curves or lines offset from the true profile at each cross-section along the feature as applicable. See FIGURE 26-5.

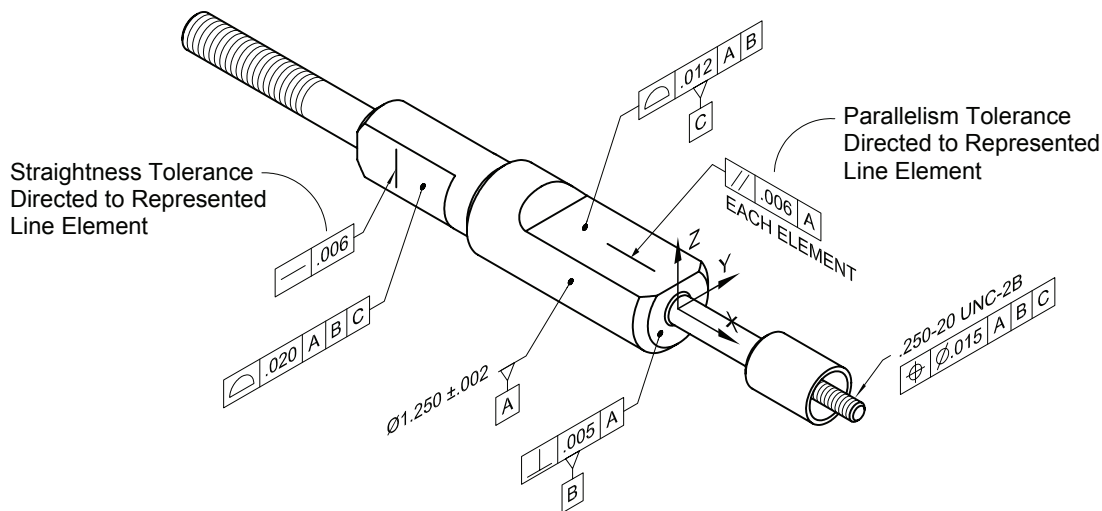

STRAIGHTNESS AND PARALLELISM DIRECTED TO A REPRESENTED LINE ELEMENT

FIGURE 26-3

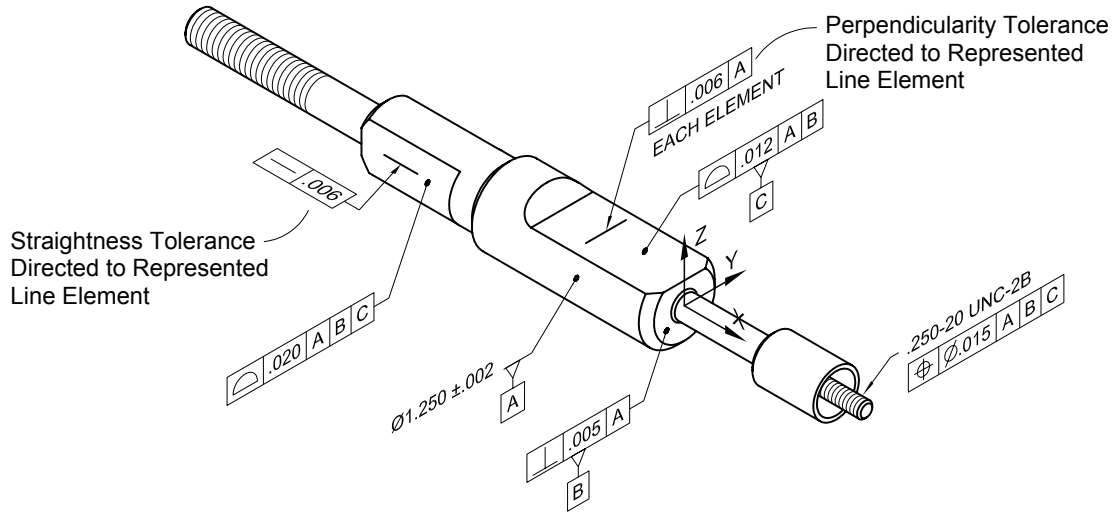

STRAIGHTNESS AND PERPENDICULARITY DIRECTED TO A REPRESENTED LINE ELEMENT
FIGURE 26-4

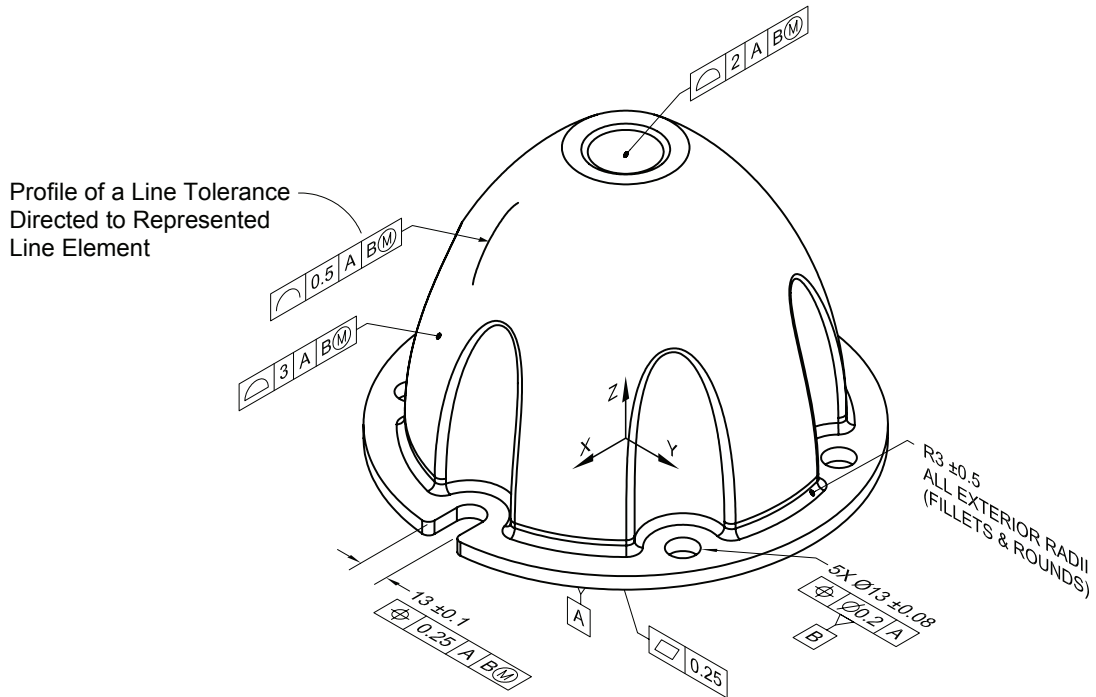

PROFILE OF A LINE DIRECTED TO A REPRESENTED LINE ELEMENT
FIGURE 26-5

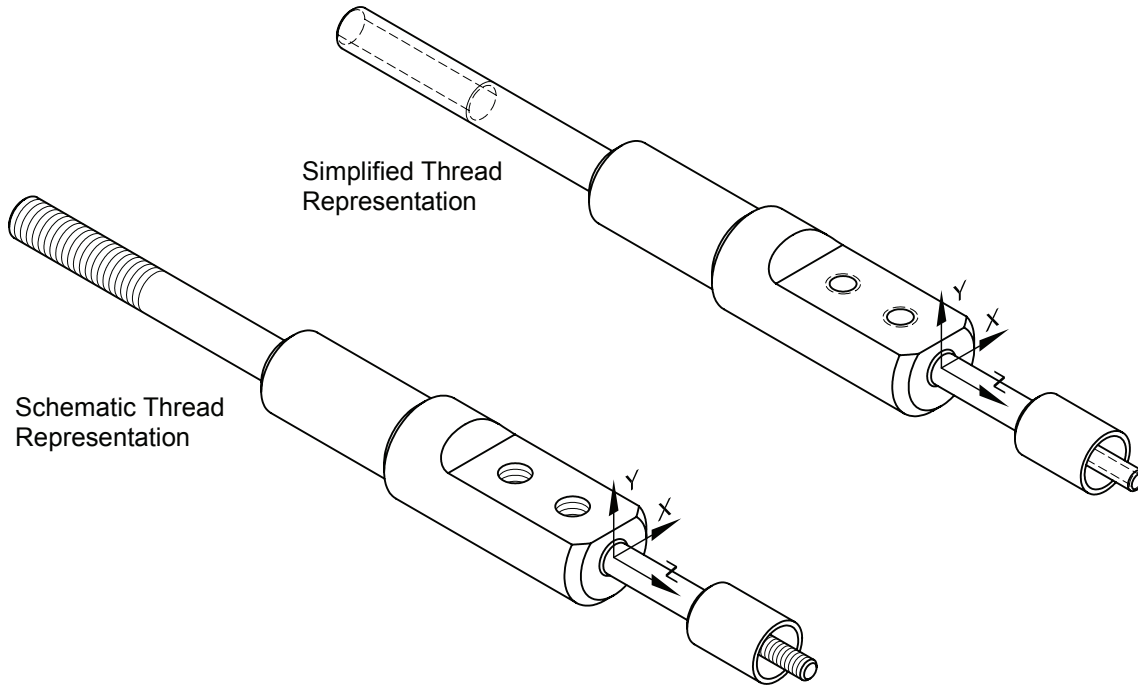

SIMPLIFIED AND SCHEMATIC THREAD REPRESENTATION ON MODELS

FIGURE 26-6

26.14.4 Completeness of Feature Modeling. Some features in the design model may be modeled using a simplified or schematic representation where appropriate. Examples include screw threads, gears, splines, knurls, fillets and rounds, and drafted surfaces. See FIGURE 26-6 for examples of screw thread representation. In cases where features are modeled in a simplified manner, full design requirements must be defined by annotation or obtainable by query. For example, if a threaded hole is modeled simply as a cylindrical hole, all necessary information about the thread and the hole must be available by querying the attributes for the feature and / or shown in the annotation for the feature. See paragraph 26.18.4.4 for information about bulk materials and consumables in models. (Author's recommendation: it is preferred practice to include and properly model draft in the design model.)

26.15 Management Data. See definition 26.4.20. Management data may reside in the model, on the drawing, in a separate file within the data set, or a combination of these.

26.15.1 Management Data Contents. Management data shall include application data, approval data, data set identification, design activity transfer data, and data set revision history.

26.15.2 Management Data in the Model. Model management data must reside on a management data annotation plane or equivalent. Users of the model must be able to access this annotation plane. It is not necessary for this annotation plane to rotate with the model.

26.16 Security Marking. Where needed, security marking must reside in the model and any other appropriate file(s) within the data set, and must be appropriately displayed on applicable drawings in the data set.

26.17 Methods of Representing and Saving Views on Models. Views and sections shall be in accordance with ASME Y14.3M and Section 3 of the DRM. The material in this section defines exceptions and additions to the requirements in ASME Y14.3M and Section 3 of the DRM. All contents of saved views and sections shall be associated to the design model.



26.17.1 Rules for Saved Views and Sectional Views on Models. Views may be saved with a design model.

1. Saved views shall be identified.
2. Saved views shall be retrievable by the user as needed.
3. Saved views shall include a model coordinate system that indicates the orientation and location of the view relative to the model, and the viewing direction.
4. Saved views may contain annotation planes, annotation, and geometry.

26.17.2 Rules for Sectional Views on Models. Views may be saved with a design model.

1. Sectional views shall be derivatives that are associated to the design model and shall update automatically if the model is changed.
2. Sectional views shall be the same scale as the design model.
3. Cutting planes shall be planar surfaces or collections of planar surfaces bounded by continuous lines or phantom lines. See FIGURES 26-7 and 26-8 for examples of cutting planes.
4. All cutting planes shall be identified and associated to the applicable sectional view.
5. One or more visible arrows shall be used to show the viewing direction for each section.
6. Upper case letters shall be used to identify sectional views and cutting planes.
7. Sectional views shall be labeled as "SECTION A" if one viewing arrow is used or "SECTION A-A" if two viewing arrows are used.
8. Section letters shall be used in alphabetical order. The letters I, O, Q, S, X, Y, Z shall not be used. If all letters in the alphabet are used then double letters may be used, such as AA, AB, AA-AA, AB-AB, etc.
9. Sectional views on models may be shown similar to traditional sectional views where material on the near side of the cutting plane(s) is removed and only the remaining portion of the part is shown, or as in situ sectional views. In situ sectional view geometry is located where the cutting planes intersect the surfaces of the model. Section lines are optional. See FIGURES 26-7c & d and 26-8.

FIGURE 26-7a shows an axonometric view of a model with cutting plane A. FIGURE 26-7b shows the sectional view resulting from the cutting plane shown in FIGURE 26-7a. FIGURES 26-7a and b would be used together. FIGURE 26-7c shows an axonometric view with cutting plane A and the resulting cut geometry in situ. FIGURE 26-7d includes in situ section lines. Options a-b, c, or d may be used.
10. Broken-out sections on design models shall be created as offset sections.
11. Offset Sections. The cutting planes for offset sections shall be connected to one another. See FIGURE 26-8.
12. Sectional View Restrictions. The following sectional view types are not allowed on design models. The need for these is negated by using in situ sections.
 - a. Removed sectional views are not allowed on design models.
 - b. Aligned sectional views are not allowed on design models.
 - c. Rotated sectional views are not allowed on design models.
 - d. Revolved sectional views are not allowed on design models.

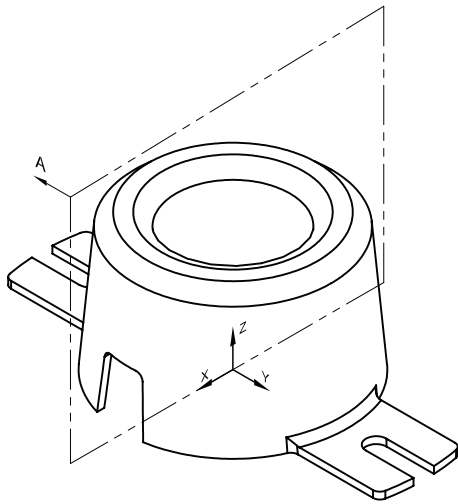

a. Model and Cutting Plane

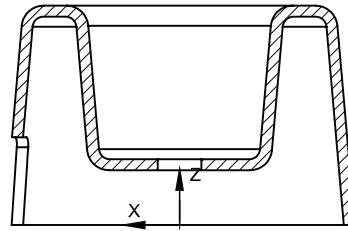

SECTION A

b. SECTION A in Saved View

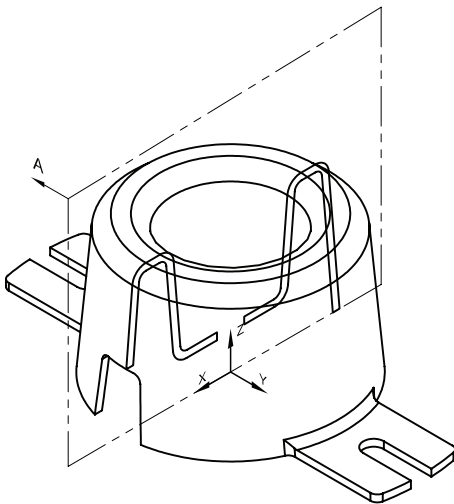

c. Model, Cutting Plane and Cut Geometry

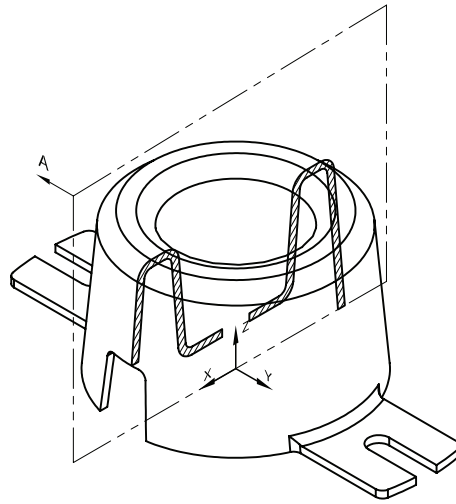

d. Model, Cutting Plane, Cut Geometry and Section Lines

CUTTING PLANE AND SECTIONS – ORTHOGRAPHIC AND AXONOMETRIC VIEWS

FIGURE 26-7

26.18 General Design Model Requirements. A design model represents the perfect design, the goal or best-case result for the design. This includes the model geometry (form, size, orientation, and location of all features on the model) and the material(s) (metals, polymers, ceramics, composites, etc.) represented in the model and their properties. Design models and annotation on design models shall meet the following requirements.

26.18.1 Model Dimensions. Features shall be modeled at their mean (nominal), minimum limit, or maximum limit. The dimensional limit used shall be specified in a note in the data set. Exceptions shall be specified as a local note or attribute for each feature modeled at a different condition. For example, consider a model with all features modeled at their mean size which has two holes modeled at their Maximum Material Condition (MMC). The specifications for each of these two holes should indicate (either visibly or by query) that the hole was modeled at MMC.

26.18.1.1 Limit Dimensions. If the size of a feature of size is specified as a limit dimension, the feature may be modeled at any size within the limits.

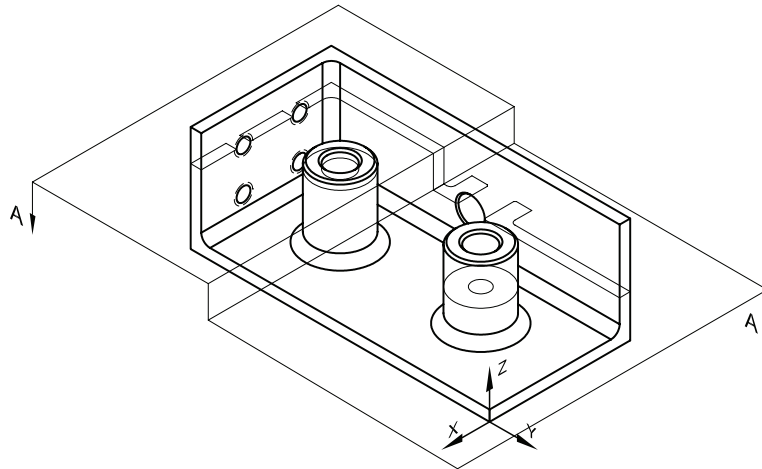

a. Model with Offset Cutting Plane and Cut Geometry

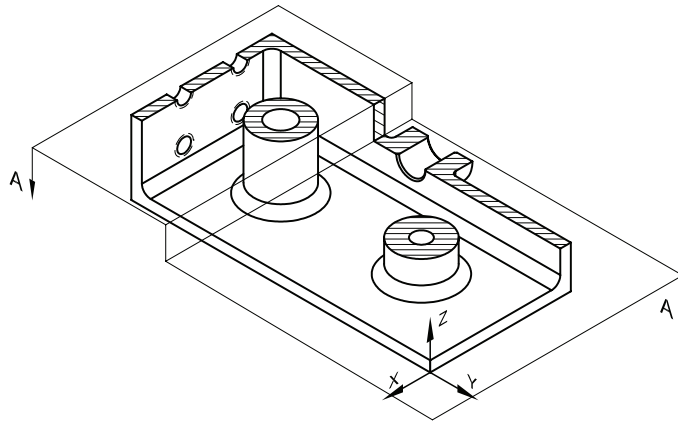

b. Sectioned Model with Offset Cutting Plane:
Continuous Line Cutting Plane Boundaries

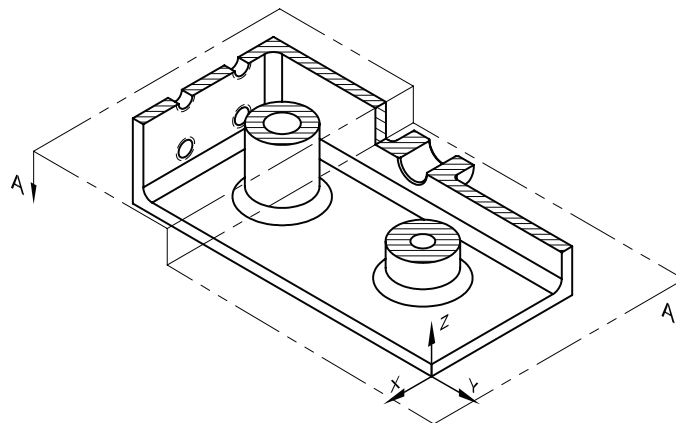

c. Sectioned Model with Offset Cutting Plane:
Phantom Line Cutting Plane Boundaries

OFFSET CUTTING PLANES AND SECTIONS – AXONOMETRIC VIEWS

FIGURE 26-8



26.18.1.2 Interpretation of Limits. All limits are absolute. Rounding down to an upper limit or rounding up to a lower limit is not allowed per ASME Y14.5M-1994 and per paragraph 5.3.19.1 in the DRM.

26.18.2 Design Model Scale. A design model must be modeled full scale (1:1).

26.18.3 Design Model Precision. The required precision (number of significant figures or decimal places) shall be specified within the data set. The required precision shall not be greater than the precision of the design model.

26.18.4 Completeness of Design Models. The design model shall contain all the information required for complete product definition, including geometry, annotation, and attributes. Notation shall be included if a product has been purposefully incompletely modeled, as may be the case with symmetrical parts, threaded holes, gears, etc. See paragraphs 26.14.4 and 26.18.4.1.

26.18.4.1 Features Not Required in the Model. It may be acceptable to model a part without including certain features, that is, it may not be necessary to include a feature in the model to convey the design requirements. For example, sometimes a sharp corner is modeled, but it is dimensioned and toleranced with a maximum single limit dimension such as R0.25 MAX. See FIGURE 26-34d. In such a case it is determined that a zero radius or sharp corner is acceptable for the design, as in this example only the maximum limit has been specified, and zero is the other unspecified limit. Note: The radius may be included in the model if desired; however, it is not mandatory. Where a minimum single limit dimension is used the feature should be included in the model. For example, if a radius is specified as R1.2 MIN, then the radius should be modeled at 1.2mm.

As recommended in paragraph 26.14.4, it is best practice to include draft in the model. However, draft may be omitted and defined using annotation if the design requirements are sufficiently defined and risks of doing so are acceptable to all involved.

Warning: situations where it is acceptable not to model features is very limited.

26.18.4.2 Completeness of Assembly Models. Assemblies shall be modeled per paragraph 26.18.4, except parts and sub-assemblies may be represented in a simplified manner. Parts and sub-assemblies must be adequately represented such that their identity, orientation, and location within the assembly are understood. Annotation may also be used to define their identity, orientation, and location. Assemblies may be modeled fully assembled, partially assembled, or as an exploded assembly.

26.18.4.3 Completeness of Installation Models. Installations shall be modeled per paragraphs 26.18.4 and 26.18.4.1, except parts and sub-assemblies may be represented in a simplified manner such that their installation and space requirements are understood. The maximum envelope may be shown for parts and sub-assemblies in addition to or in place of the part and assembly geometry. Annotation may also be used to define the installation requirements.

26.18.4.4 Bulk Materials and Consumables in Design Models. It is not mandatory for bulk materials and consumables to be physically represented in the design model. Items such as paint, adhesive, tape, sealant, thread-locking compounds, locking wire, etc. may be represented by attributes or annotation. As with traditional technical documentation, the amount of bulk materials or consumables required and where they are required must be clearly defined. This may occur on the design model or within a referenced document, such as an assembly procedure. The rules for including and representing bulk materials and consumables must be addressed on a project-by-project basis.

26.19 Requirements for Product Definition Data Sets. This section defines the rules for applying, displaying, and querying product definition data in models and drawings.

26.19.1 Display Management. The display management system shall provide the ability to display or turn off annotation selectively or globally.

26.19.2 Availability of Hard Copy Documents. A hard copy of any visual portion of the data set shall be obtainable on demand, that is, any graphical display or drawing within the data set must be printable. Hard copies intended to be used as engineering drawings must meet the requirements of paragraph 26.11.5.6 and other applicable drawing standards.

26.19.3 Using Drawings and Models. Depending on the desired structure of the data set, drawings and design models may be used separately or in conjunction as part of the product design definition data. Product definition data may be fully disclosed using an annotated model, a combination of an annotated model and a drawing, a combination of a model and a drawing, or a drawing alone. Complexity of geometry, project requirements, contractual requirements, and limitations and capabilities of downstream entities and processes are some of the factors that must be considered when choosing the optimal structure for the product definition data set.

FIGURE 26-9 shows a model. (Note: A model may include annotation.)

FIGURE 26-10 shows a drawing with orthographic views based on the design model shown in FIGURE 26-11.

FIGURE 26-11 shows a model with no annotation to be used as the basis for the drawing in FIGURE 26-12.

FIGURE 26-12 shows a drawing with annotated orthographic and axonometric views based on the design model shown in FIGURE 26-11.

FIGURE 26-13 shows a drawing with an annotated axonometric view based on the design model shown in FIGURE 26-11.

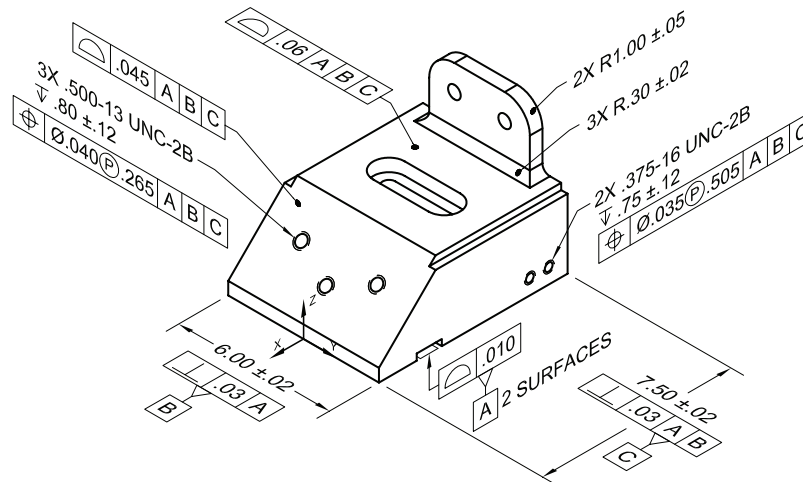

MODEL – MAY STAND ALONE

FIGURE 26-9

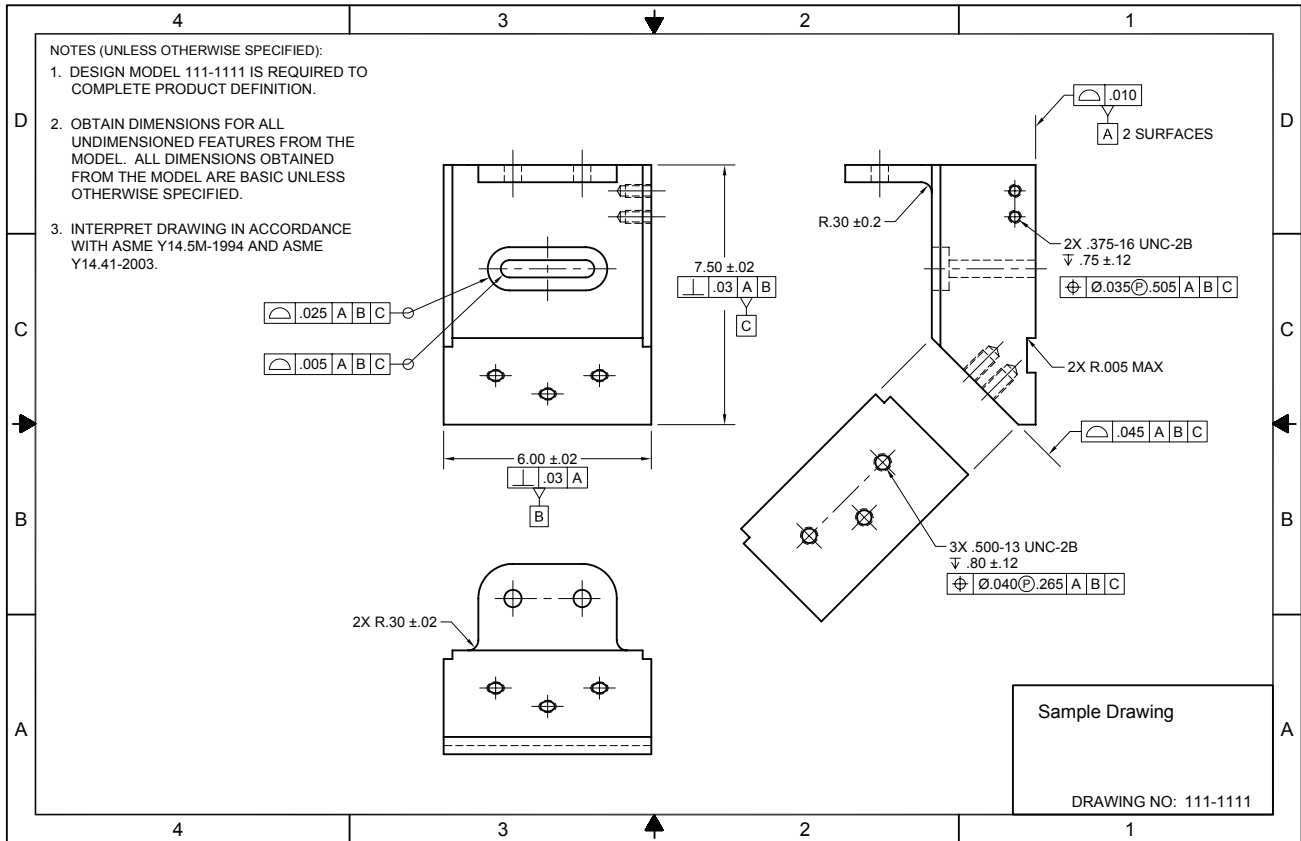

DRAWING WITH ORTHOGRAPHIC VIEWS
TO BE USED IN CONJUNCTION WITH THE DESIGN MODEL IN FIGURE 26-11
FIGURE 26-10

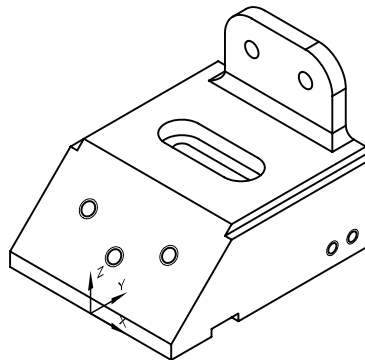

Model #111-1111

DESIGN MODEL – TO BE USED IN CONJUNCTION WITH A DRAWING
FIGURE 26-11

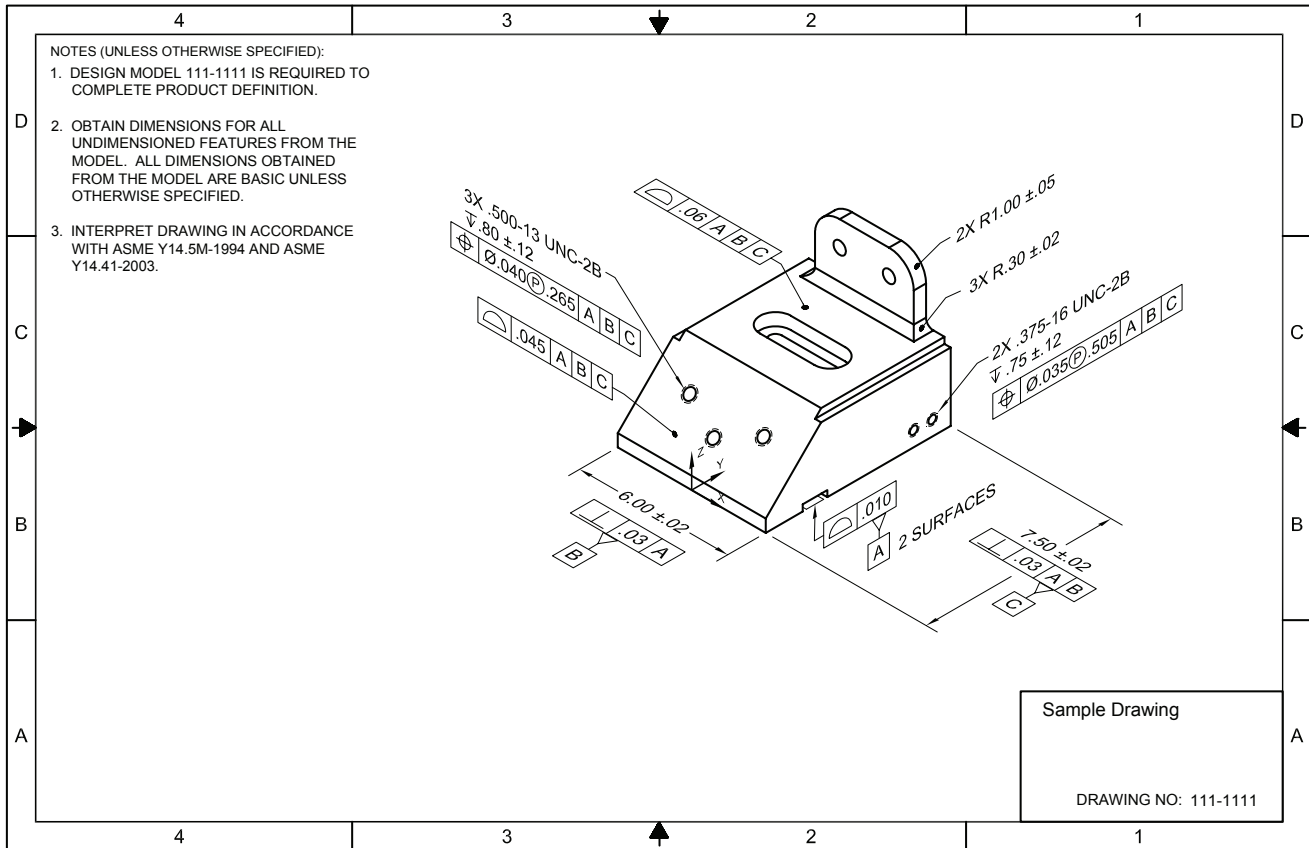

DRAWING WITH AXONOMETRIC VIEW
TO BE USED IN CONJUNCTION WITH THE DESIGN MODEL IN FIGURE 26-11
 FIGURE 26-13

26.19.4 Requirements for Models. These requirements apply to design models and any annotation or attributes applied directly to the model.

26.19.4.1 Associativity. Related digital elements on design models must be associated to one another and queryable individually and as a group.

1. Association. Annotation may be associated to model geometry, supplemental geometry, attributes, model coordinate systems, and other annotation. Annotation may be associated to one or more geometric elements or features, or to a complete or partial elements or features. See FIGURES 26-19 – 26-26 for examples of queries and their results, where each set of results is a function of the association between the queried element and the elements making up the results of the query.
2. Selecting Associated Elements. Selecting or querying a digital element that is part of an associated group shall distinctly return or highlight all entities within that associated group. See FIGURE 26-25.

26.19.4.2 Annotation Plane Orientation. The relationship (orientation and location) of each annotation plane and the model shall remain constant while the model is rotated or otherwise manipulated in 3D. Annotation planes shall not be used if the CAD system does not support the constant relationship between annotation planes and the model. See FIGURES 26-14 and 26-15.

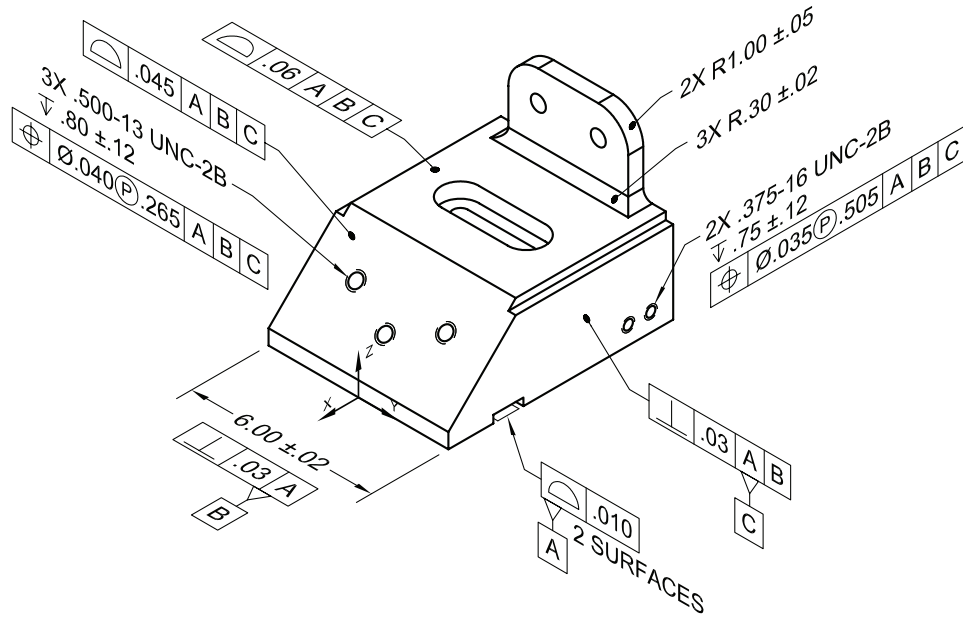

ANNOTATION PLANES – BEFORE ROTATING MODEL
FIGURE 26-14

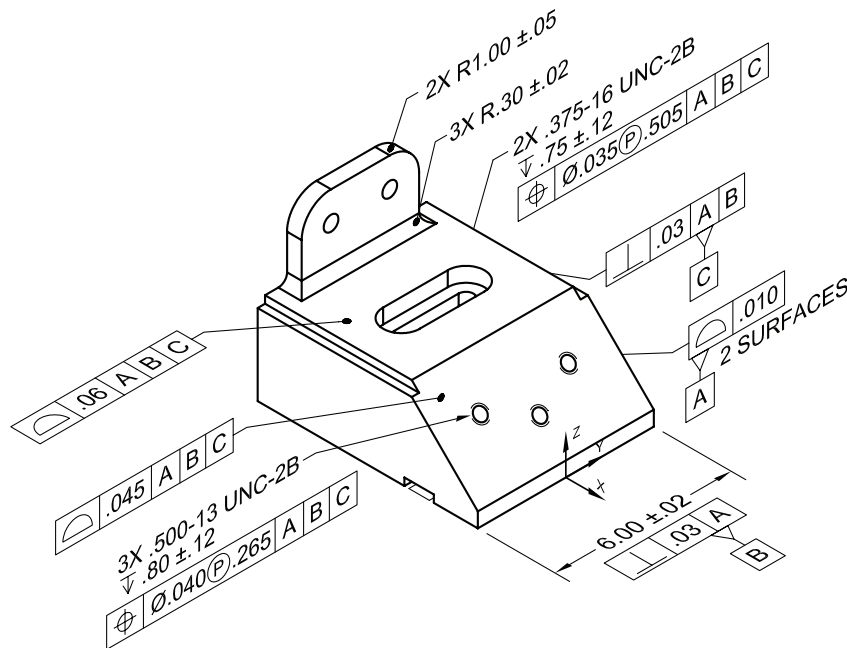

ANNOTATION PLANES – AFTER ROTATING MODEL
FIGURE 26-15

26.19.4.3 Attributes. Attributes provide a means to represent functional or other requirements for model features without being displayed on the model and within its visible annotation. Attributes are available through query, and are used to define feature attributes such as thread specifications, plating, processing information, etc. For example, a threaded pin may be simply modeled as a cylinder, but upon query, a dialog box may appear with information about the type and class of thread, length of thread, etc. See FIGURE 26-16 for examples of attribute queries and their results.

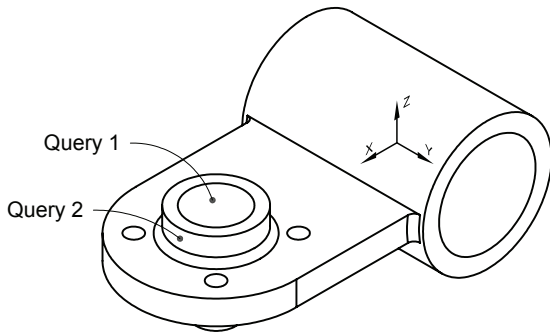

ATTRIBUTES & PROPERTIES	
Feature No.	10563
Feature Type	Hole
Category	Simple
Origin	Sketch_07
Level	1
Subordinates	No
Dimensions	
Units	mm
Precision	0.0000 ▾
Diameter	Ø27.0000
Tolerance	±0.08
Depth, Length	Thru
Miscellaneous	
Surface Texture	-

Results for Query 1

ATTRIBUTES & PROPERTIES	
Feature No.	10548
Feature Type	Extrusion
Category	Additive
Origin	Sketch_04
Level	1
Subordinates	No
Dimensions	
Units	mm
Precision	0.0000 ▾
Diameter	Ø38.0000
Tolerance	±0.5
Depth, Length	12
Miscellaneous	
Surface Texture	-

Results for Query 2

ATTRIBUTE QUERY AND DISPLAY
FIGURE 26-16

26.19.4.4 Leaders. See FIGURE 26-17 for examples of the use of leaders with models. Leaders used on models shall conform to the following:

1. A leader directed to a line or symbol shall terminate in an arrowhead.
2. A leader directed to or within the boundaries of a surface shall terminate in a dot.
3. A leader directed to a Feature of Size may terminate at the intersection of the feature surface and an adjacent surface if clarity is enhanced.
4. A leader shall be associated to the line, surface, feature(s), or symbol which it identifies.

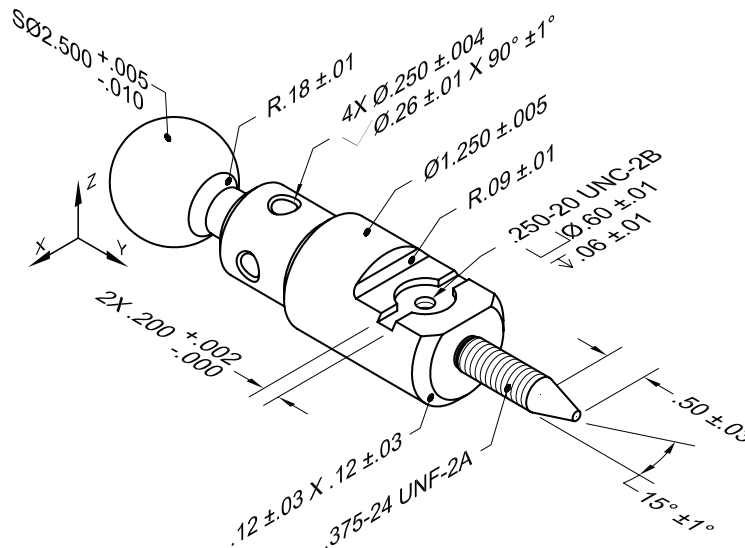

APPLYING LEADERS TO FEATURES IN THE MODEL
FIGURE 26-17

26.19.4.5 Direction Dependent Tolerance. A direction dependent tolerance controls each individual line element (or curve) on a feature, creating a set of local tolerance zones, one for each line element on the tolerated feature. In such cases the line elements and their associated tolerance zones must be oriented to the tolerated feature or datum reference frame, depending on the type of tolerance. This is best accomplished relating the tolerance zones to a datum reference frame and its associated model coordinate system. ASME Y14.41 also allows relating the direction of the tolerance zones to the part using a model coordinate system and / or by supplemental geometry. (Author's note: The only precise and unambiguous way to orient a direction dependent tolerance zone to an as-produced part is by assigning it a vector related to the model coordinate system derived from a datum reference frame.) Direction dependent tolerance zones are areas. See FIGURES 26-3, 26-4 and 26-5.

26.19.4.6 Specifying a Limited Length and Area Application. Limited length and limited areas may be specified by using supplemental geometry, annotation, a combination of the two, or by query alone on the model. (Author's note: Using query alone means that the limited length or area is not shown on the model or drawing to indicate a limited application; this practice may be more likely to lead to confusion downstream, as there are no visible clues for the recipient of the data set to understand that a specification only applies to a portion of a feature. Using a combination of supplemental geometry, annotation, and highlighting by query to indicate a limited length or area is the best practice.) See FIGURE 26-18. In this example the flatness tolerance only applies to the area indicated by the area bounded by the phantom line and the edges of the surface. The profile of a surface tolerance applies to the entire surface; in this case, the flatness tolerance refines the form control provided by the profile of a surface tolerance.

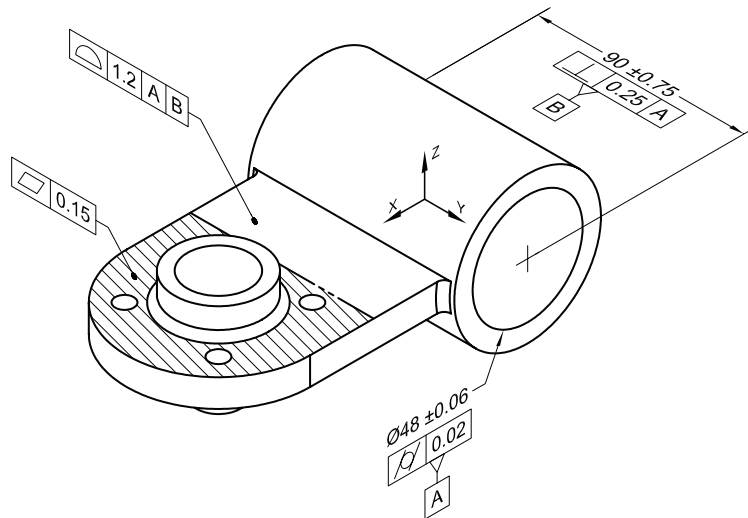

SPECIFYING A LIMITED AREA APPLICATION (EXAMPLE)

FIGURE 26-18

26.19.4.7 Querying Models. Query is the act of obtaining information from the model by using a computer program. Queries may include features, model values, model coordinate systems, annotation, supplemental geometry, performance requirements, variability (tolerances), or any other information needed from the model data set. The entire model, single features, multiple features, groups of associated features, annotation, supplemental geometry, groups of digital elements, associated digital elements, or any combination of these may be the subject of a query.

26.19.4.7.1 Query Rules. The results of a query shall be visually displayed and differentiated (highlighted) from other elements in the dataset. The model shall provide the ability to obtain by query all necessary model values, digital element identifiers, and all other data needed to complete product definition. All pertinent elements associated to the subject of the query shall be highlighted.



The model must be structured such that the relationship between annotation, model geometry, and supplemental geometry may be followed in any direction. See the following examples:

1. Annotation Query: Queried annotation returns associated model geometry, supplemental geometry, and other annotation as applicable. See FIGURES 26-19 – 26-21.
2. Model Geometry Query: Queried model geometry returns model values, associated annotation, supplemental geometry, and other model geometry as applicable. See FIGURES 26-22 – 26-25.
3. Supplemental Geometry Query: Queried supplemental geometry returns associated annotation, model geometry, and other supplemental geometry as applicable. See FIGURE 26-26.

Additional Query Requirements:

Geometric Element Query: Element of a Feature. Query of any geometric element of a feature shall result in display of the entire feature.

Associated Element Query. Query of any element within a group of associated elements shall result in display of the entire associated group.

Feature Query: Associated Group. Query of any feature within a group of associated features shall result in display of all features in the associated group.

Feature Control Frame Query: Query of a feature control frame shall result in display of the feature or features controlled by the feature control frame, datum feature symbols and / or datum target symbols for any datum features referenced in the feature control frame, and the model coordinate system associated to the referenced datum reference frame. See FIGURES 26-21 and 26-27.

Datum Target Query. Query of a datum target symbol shall result in display of all other datum target symbols using the same letter (e.g. A1, A2, A3), and any datum feature symbols using the same letter (e.g. datum feature A). See FIGURES 26-27 – 26-29.

Datum Target Geometry and Annotation Query. Query of a target point symbol, target line, target area, target leader, target area dimensions and tolerances, or target line dimensions and tolerances shall result in display of the datum target symbol associated to that geometry and all other geometry and annotation that comprises the associated group for that datum target (e.g. all geometric elements and annotation that is required to define datum target A1). See FIGURE 26-29.

Datum Feature Query. Query of a datum feature symbol shall result in display of the datum feature geometry comprising that datum feature (e.g. query of datum feature symbol A highlights datum feature A), and any datum target symbols using that same letter.

Author's Note: For those unfamiliar with the term "query", its use in ASME Y14.41-2003 is appropriate and accurate. "Query" is a formal term used in logic and database programming. To query is to ask a question to receive a specific answer. "Query" has been used in this context in computer science since at least the early 1970s, and perhaps even earlier. As an example, Structured Query Language (SQL), originally developed in the 1970s, is a powerful and easy-to-use language for relational databases that makes it easy to answer complex questions, filtering out layer-upon-layer of unwanted data to leave only the desired information.* This is exactly analogous to the process of selecting an entity in a modern CAD program to determine its properties, whether by manual selection or through a more elaborate filtering process. A CAD system is simply a database management system, and a CAD file is a database (or dataset) – the main difference between a CAD dataset and a traditional dataset is that the CAD file primarily contains geometric and spatial data, whereas a traditional dataset may contain any type of data. Also, the output from a CAD system is primarily graphical, traditionally in the form of printed engineering drawings, today also in the form of annotated 3D models.

* SQL – Structured Query Language, 2nd Ed. Hursch, C.J. and J.L., Blue Ridge Summit, PA, Windcrest/McGraw-Hill, 1991

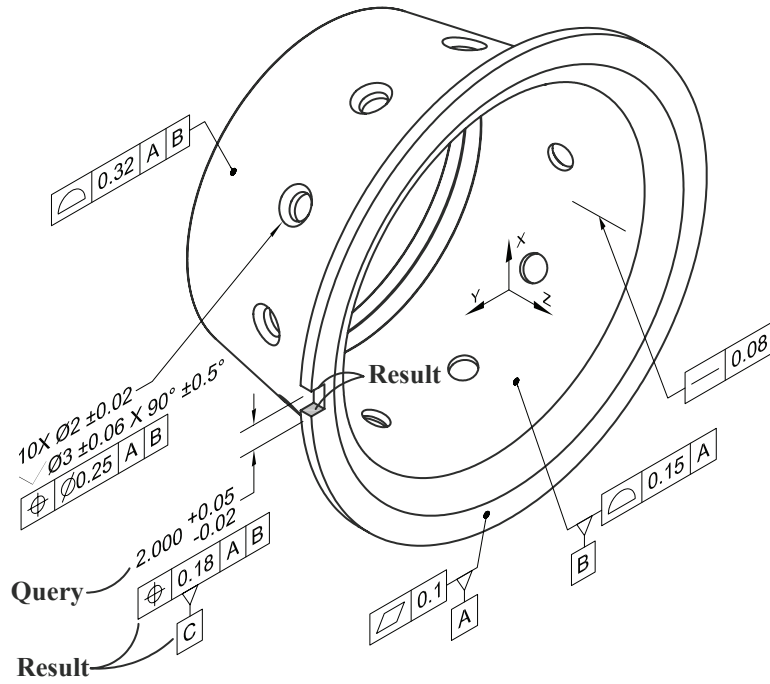

a. Annotation Query:
Size Dimension and Tolerance (Feature of Size)

QUERYING MODELS - EXAMPLES

FIGURE 26-19

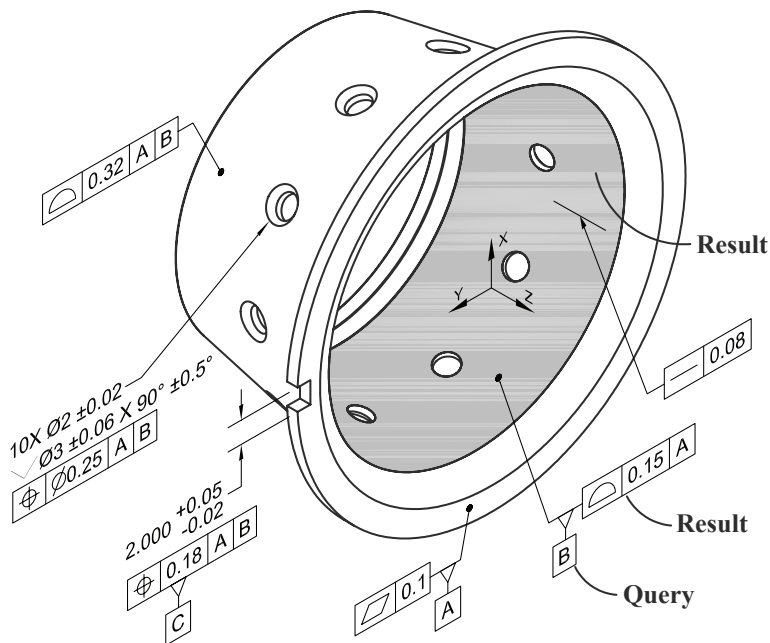

b. Annotation Query:
Datum Feature Symbol

QUERYING MODELS - EXAMPLES

FIGURE 26-20

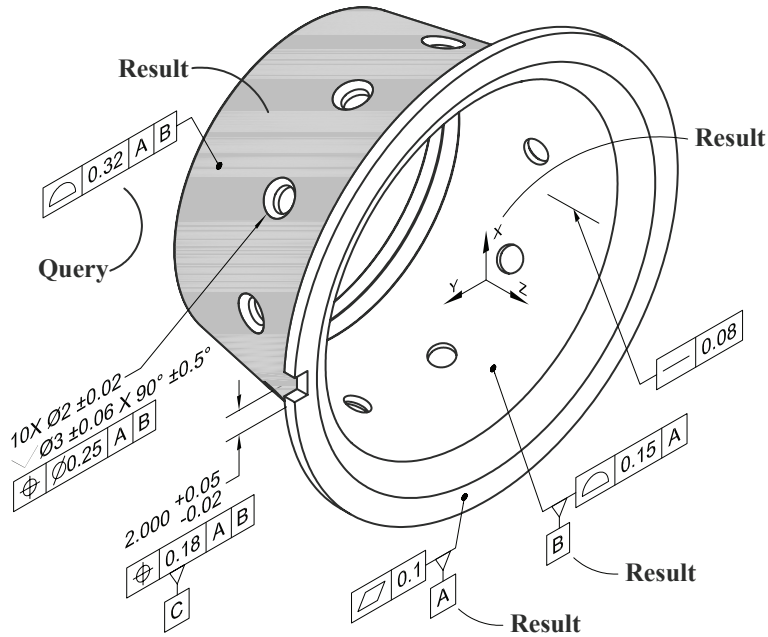

c. Annotation Query:
 Feature Control Frame

QUERYING MODELS - EXAMPLES
 FIGURE 26-21

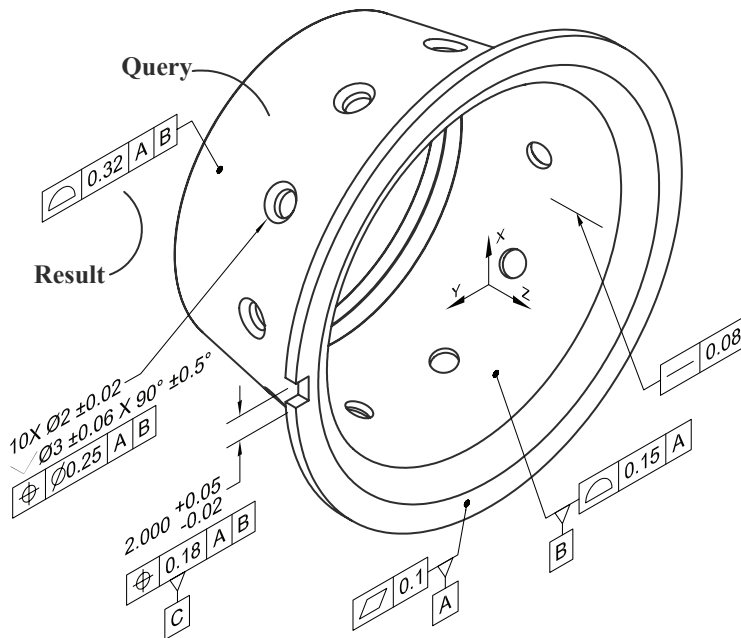

d. Model Geometry Query:
 Surface

QUERYING MODELS - EXAMPLES
 FIGURE 26-22

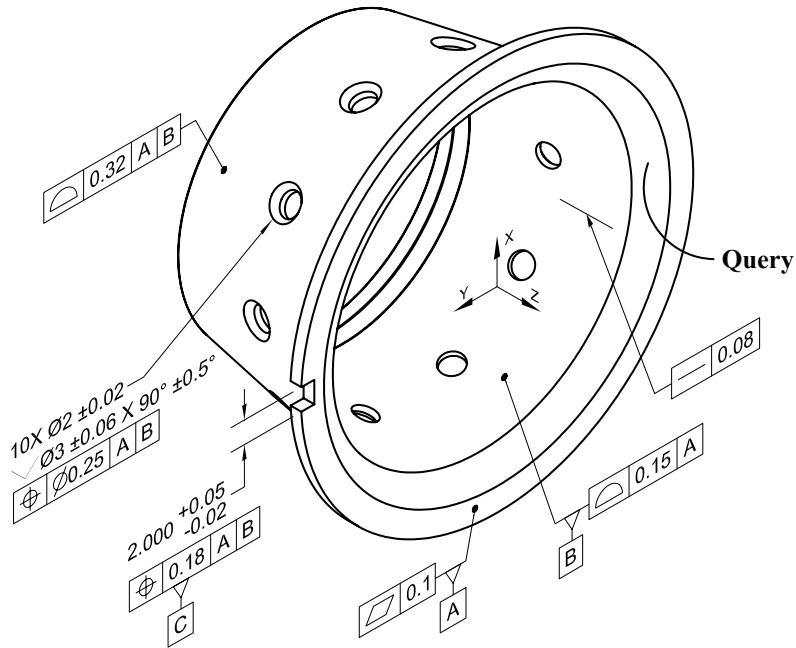

e. Model Geometry Query:
Radius [Query Returns Model Value]

ATTRIBUTES & PROPERTIES	
General	
Feature No.	435
Feature Type	Radius
Category	Tangent
Origin	Fillet
Level	1
Subordinates	No
Dimensions	
Units	mm
Precision	0.0000 ▼
Dimension	R2.0000
Tolerance	-
Dim Class	Basic
Miscellaneous	
Surface Texture	-

Result

QUERYING MODELS - EXAMPLES
FIGURE 26-23

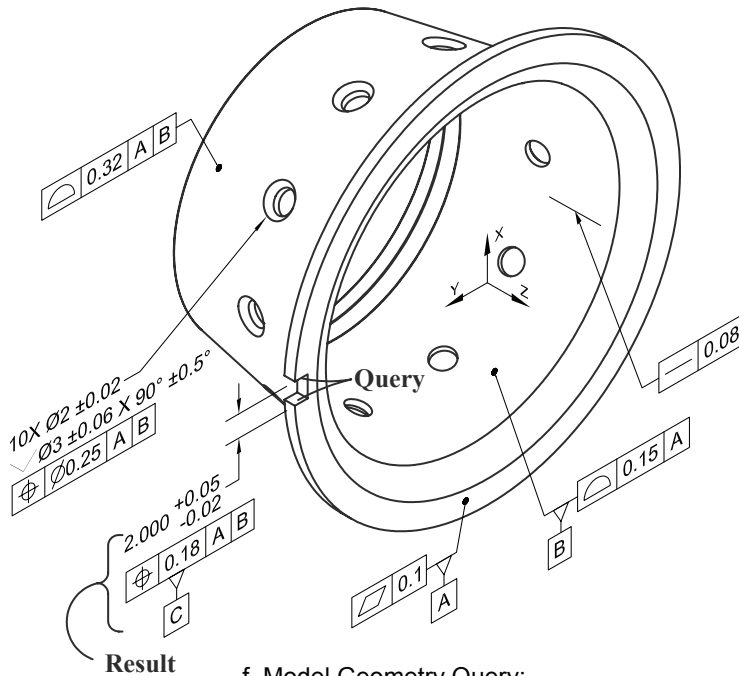

f. Model Geometry Query:
Feature of Size

QUERYING MODELS - EXAMPLES
FIGURE 26-24

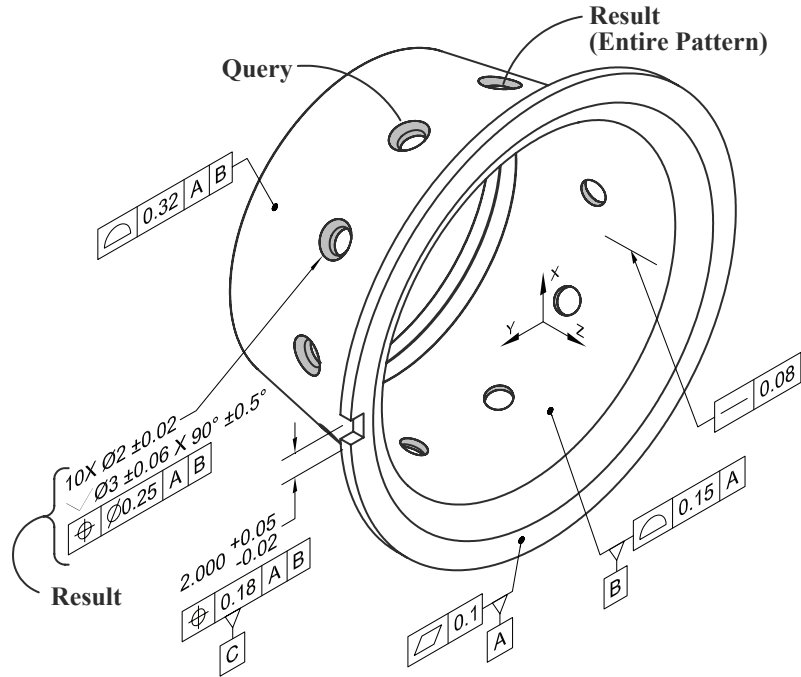

g. Model Geometry Query:
 Feature in a Pattern

QUERYING MODELS - EXAMPLES
 FIGURE 26-25

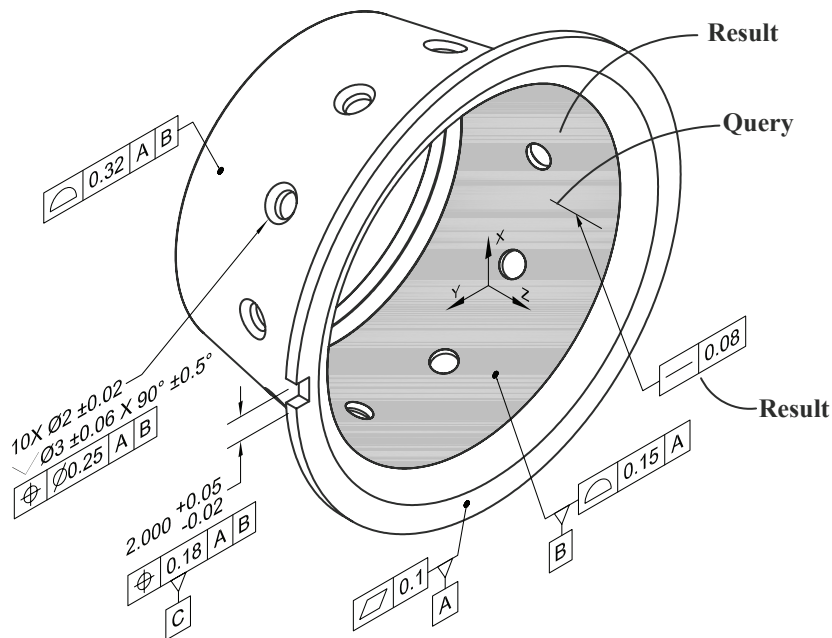

h. Supplemental Geometry Query:
 Represented Line Element

QUERYING MODELS - EXAMPLES
 FIGURE 26-26

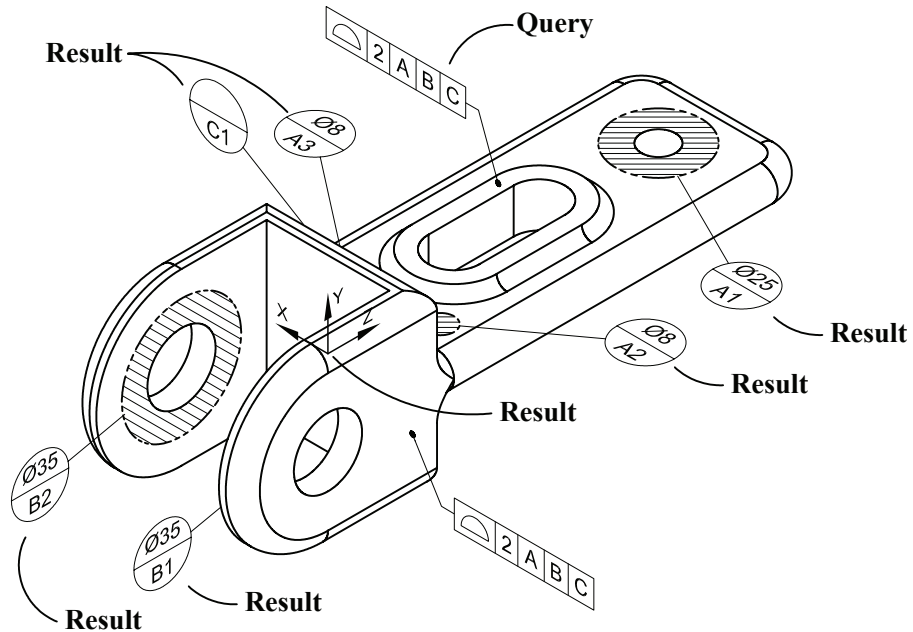

i. Query of Feature Control Frame: Datum Targets

QUERYING MODELS - EXAMPLES
 FIGURE 26-27

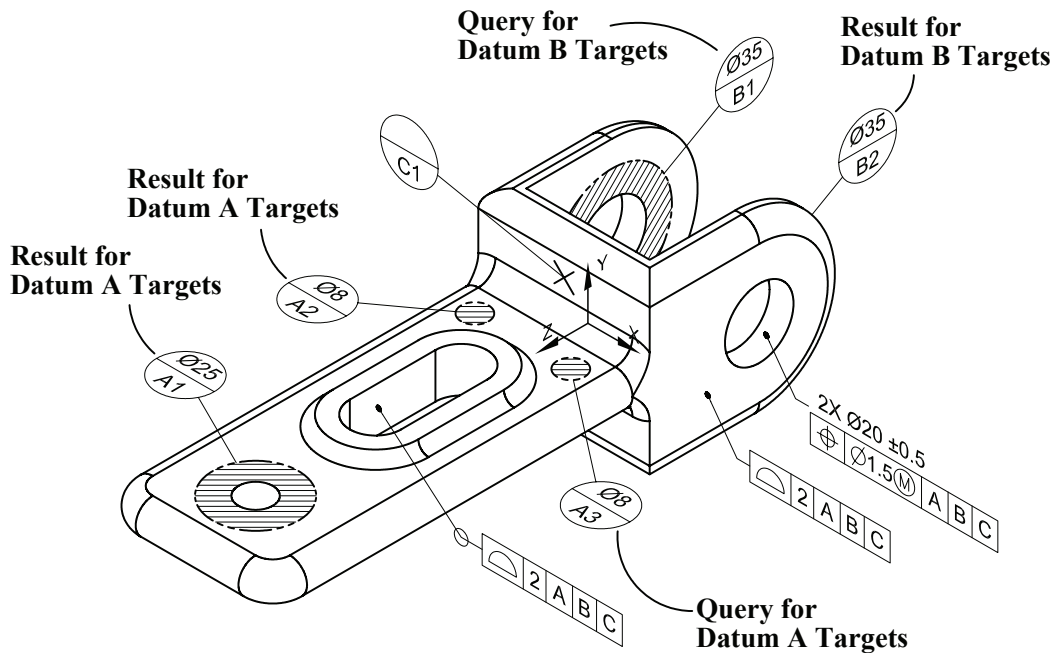

j. Queries of Datum Target Symbol

QUERYING MODELS - EXAMPLES
 FIGURE 26-28

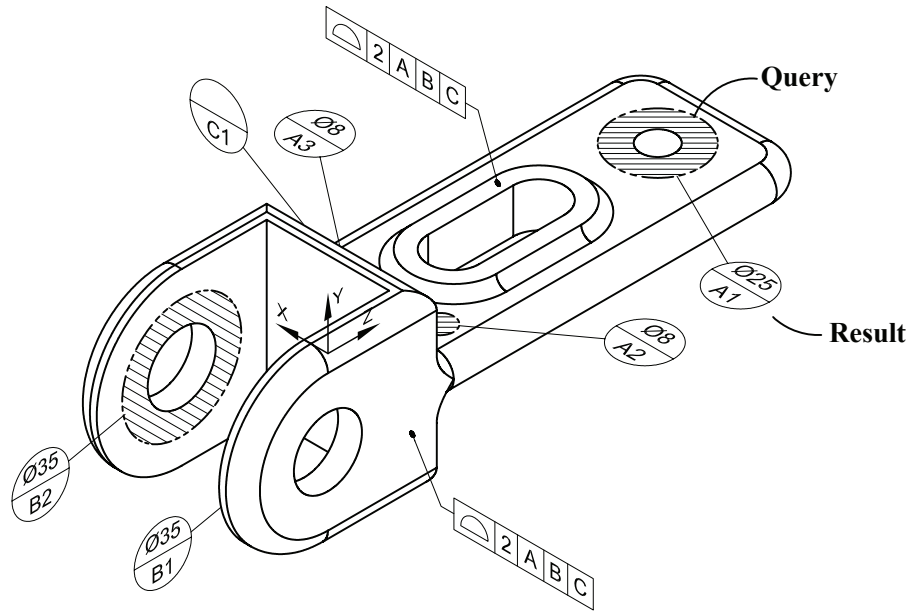

k. Query of Datum Target Geometry

QUERYING MODELS - EXAMPLES

FIGURE 26-29

26.19.5 General Drawing Requirements. General requirements for views and sectional views on drawings are defined in ASME Y14.3 and paragraph 3.9 of the DRM. The material in this paragraph (26.19.5) and its subparagraphs applies to drawings – it provides additional techniques and restrictions to the material in paragraph 3.9. In addition to using orthographic views, ASME Y14.41 allows for using axonometric views, annotating axonometric views, deriving axonometric sectional views from axonometric views, and for using fully-dimensioned or partially-dimensioned drawings.

26.19.5.1 Orientation of Orthographic Views. Orthographic views may be oriented to the model by referencing or associating the view to the model coordinate system.

26.19.5.2 Relating Axonometric Views on a Drawing to the Model. Axonometric views on the drawing must include a model coordinate system that orients and locates the view to the model. See FIGURES 26-12, 26-13, 26-30, 26-31, 26-47 and 26-49 for examples.

26.19.5.3 Sectional Views on Drawings. Sectional views on drawings may be axonometric views or orthographic views.

26.19.5.3.1 Rules for Sectional Views on Drawings.

1. Sectional views may be taken from axonometric views. See FIGURES 26-30 and 26-31.
2. Cutting planes must be shown in the view from which a sectional view was taken. The cutting plane must clearly show where the model has been cut, the direction of the sectional view, and which side or portion of the part has been removed. See FIGURES 26-30 and 26-31
3. Cutting planes on axonometric views must be planar surfaces or collections of planar surfaces bounded by continuous lines or phantom lines.
4. One or more visible arrows shall be used to show the viewing direction for each section.
5. Upper case letters shall be used to identify sectional views and cutting planes.



6. Section letters shall be used in alphabetical order. The letters I, O, Q, S, X, Y, Z shall not be used. If all letters in the alphabet are used then double letters may be used, such as AA, AB, AA-AA, AB-AB, etc.
7. Sectional views shall be labeled with a single letter if one viewing arrow is used (e.g. "SECTION A"), or with two letters separated by a dash if two viewing arrows are used (e.g. "SECTION A-A").
8. Sectional views may be shown similar to traditional sectional views where material on the near side of the cutting plane(s) is removed and only the remaining portion of the part is shown, or as in situ sectional views. In situ sectional view geometry is located where the cutting planes intersect the surfaces of the model. Section lines are optional. See FIGURES 26-30 and 26-31.
9. Sectional views taken from an axonometric view may be shown in the proper orientation or they may be rotated into the viewing plane of the drawing.
10. Offset Sections. The cutting planes for offset sections in axonometric views shall be connected to one another. See FIGURE 26-8. Unlike offset sectional views on models, the cut geometry in offset axonometric sectional views on drawings may be shown as if it all was in a single plane.
11. Aligned Sections. Axonometric aligned sectional views on drawings may be shown with all the cut geometry rotated into a single plane normal to the view, or with the cut geometry in its actual orientation.

26.20 Annotation in Models. This section defines the rules for applying and displaying annotation in models.

26.20.1 General Annotation Plane. General notes, flagnotes, and annotation that is not associated to a model or saved view in the model must reside on an annotation plane that remains static when the model is rotated.

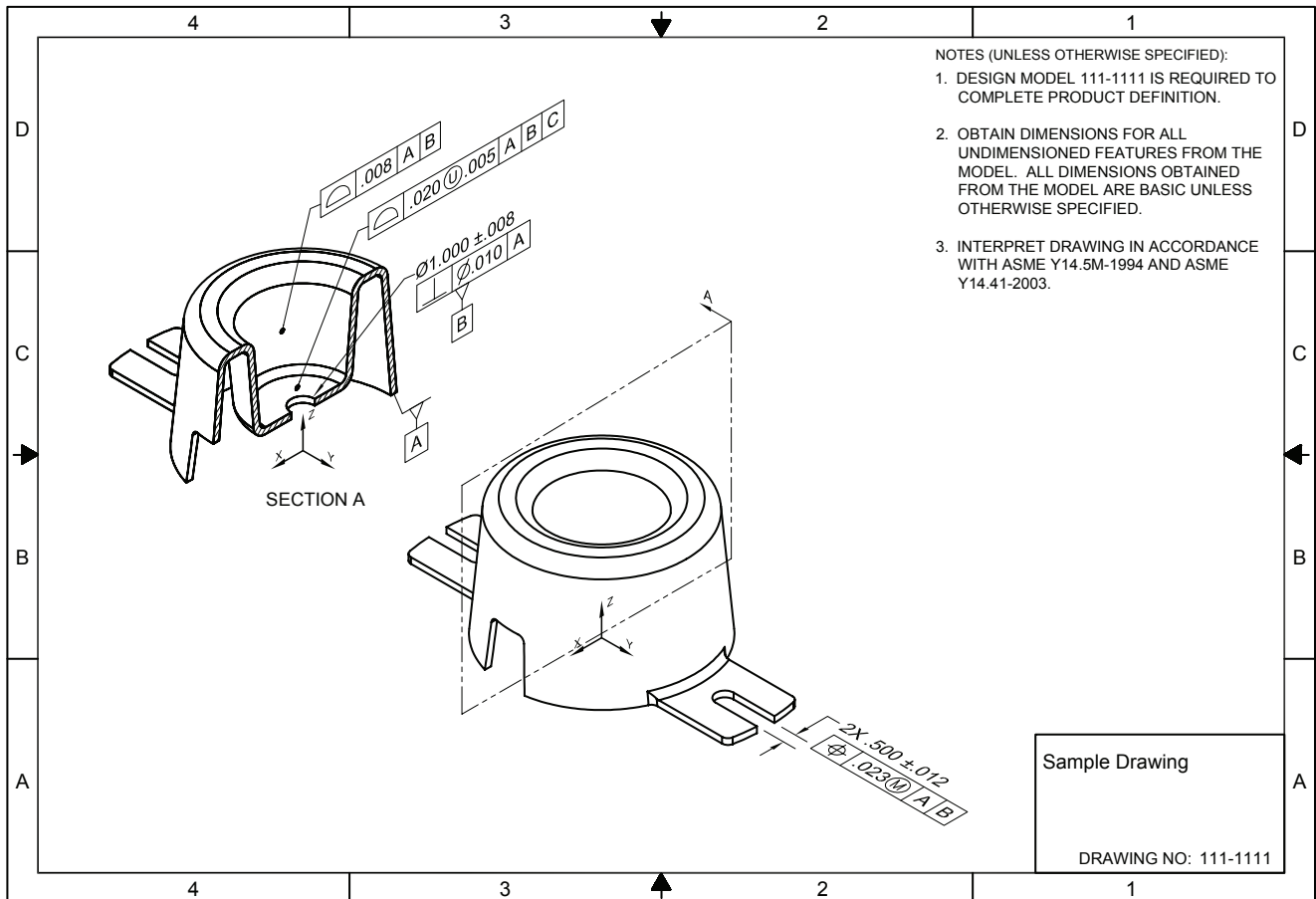

DRAWING WITH AXONOMETRIC SECTIONAL VIEW
FIGURE 26-30

26.20.2 Notes in an Annotated Model. The use, rules, and format of general notes, flagnotes, and local notes are similar to those defined in ASME Y14.100 and Section 9 of the DRM. Model-specific requirements follow:

1. General Notes. It is not necessary for general notes to be associated to other digital elements. Default geometric tolerances may be included in the general notes.
2. Flagnotes. The flagnote text, number, and symbol are included with the general notes on a general annotation plane. Flagnote text, note numbers, and symbols must be associated to the applicable elements in the model. A flagnote number and symbol shall be applied to the model at each applicable location. Locally applied flagnote data must rotate with the model.
3. Local Notes. Local notes must be associated to the applicable elements in the model and must rotate with the model.

26.20.3 Special Notations and Symbols. The use, rules, and format for special notations and symbols are similar to those defined in ASME Y14.100 and Section 9 of the DRM. Model-specific requirements follow:

1. Special notations and symbols may be applied globally or locally, and may be used in general notes, flagnotes, and local notes.
2. Globally applied special notations shall reside on a general annotation plane. It is not necessary for globally applied special notations to be associated to other digital elements.
3. Locally applied special notations must be associated to the applicable elements in the model and must rotate with the model.

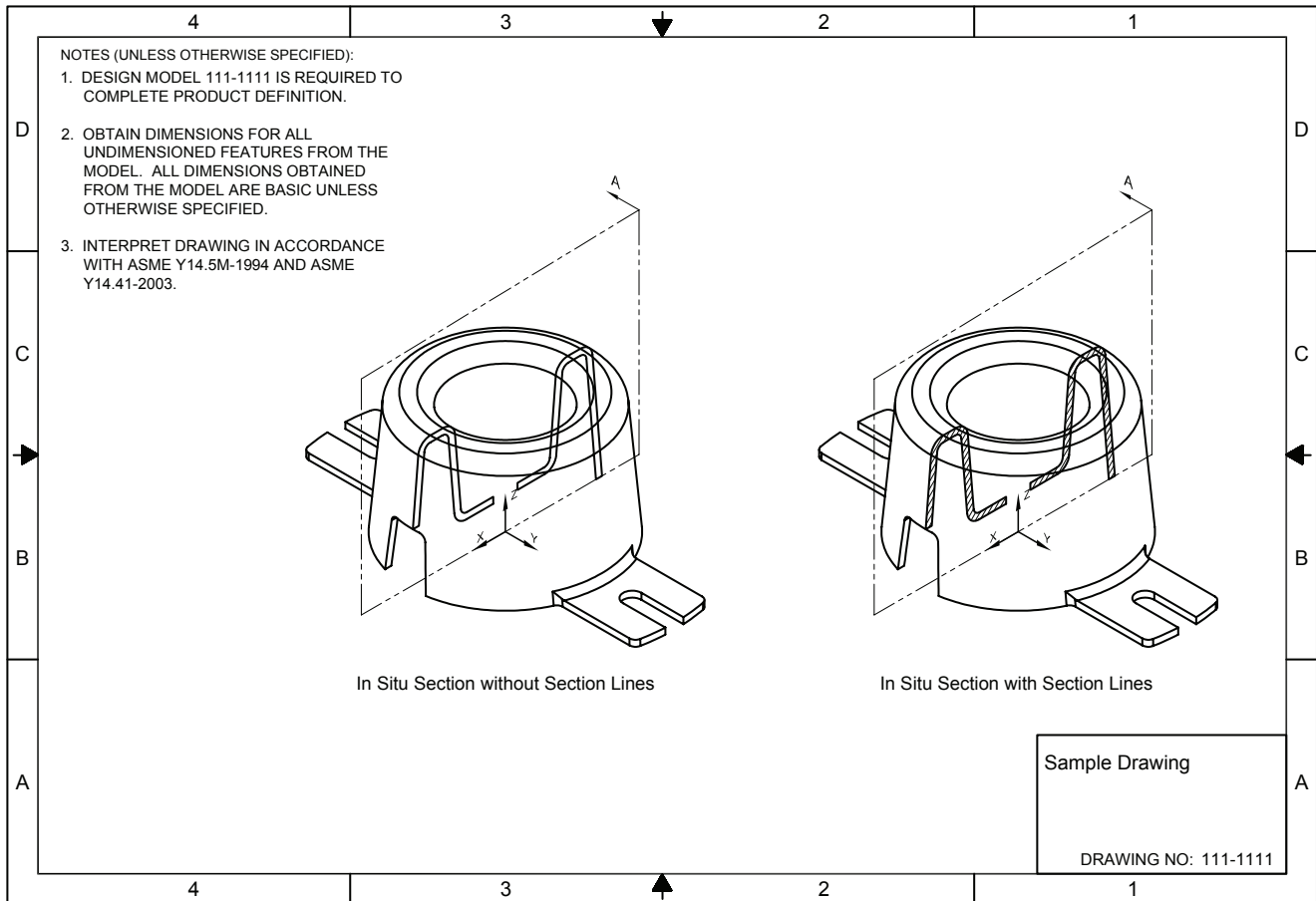

DRAWING WITH AXONOMETRIC IN SITU SECTIONAL VIEW - TWO OPTIONS

FIGURE 26-31

26.21 Annotation on Drawings. This section defines the rules for applying and displaying annotation in drawings.



26.21.1 Local Notes in Axonometric Views on Drawings. Local notes in axonometric views must be clear and must be directed to the applicable feature(s) with a leader.

26.22 Obtaining Model Values. Model values are dimensional values obtained by querying the model geometry. Given that models in the dataset may be presented with or without dimensions displayed (partially dimensioned or completely undimensioned), it may be necessary to obtain model values to complete product definition. Model values may be needed to find:

1. The form of a feature. This may include radii, curved, contoured, or complex surfaces, draft, etc.
2. The size of a feature, feature of size, or a feature within a pattern. This may be a local size or the size of the entire feature.
3. The distance between features, points, lines, surfaces, elements, model coordinate system, or any combination of these on the model.
4. The angle between features, points, lines, surfaces, elements, model coordinate system, or any combination of these on the model.
5. The orientation of features, lines, surfaces, or elements on the model to the model coordinate system.
6. The location of features, lines, surfaces, or elements on the model to the model coordinate system.

26.22.1 Obtaining Model Values with Regards to Model Coordinate Systems. Model values obtained to determine orientation, location, or any relationship to a datum reference frame must be done in the proper context – they must be obtained relative to the applicable model coordinate system. Exceptions include size, form, depth, radii, chamfers, and distance, as these are local values and essentially return a magnitude. These queries essentially return the same value regardless of which coordinate system is active. The form of some complex or contoured surfaces may need to be queried in the context of the proper model coordinate system to ensure that the coordinates of any points or other values extracted from the surface return the required values.

26.23 Resolved Dimensions. Resolved dimensions are the dimensions shown on an annotated model, shown on a drawing, or obtained by querying a model. Resolved dimensions are representations of model values that have been rounded to some precision. See definition 26.4.29.

26.23.1 Rounding and Truncation within the CAD system or Query Tool. Rounding may occur twice within a system. Model values are rounded or truncated to some precision (number of decimal places) by the limitations of the CAD system or query tool; resolved dimensions are rounded by the choice of the person preparing the annotated model or drawing. When preparing an annotated model or drawing, model values must be rounded to the precision or number of decimal places needed to satisfy the design requirements. Rounding of model values for resolved dimensions shall meet the requirements of IEEE/ASTM SI 10 – these requirements apply to inch and metric values.

26.23.2 Resolved Dimension Rules.

1. See paragraph 26.23.1 for rounding requirements.
2. Resolved dimension values are absolute values, understood to be continued with a series of zeroes. See paragraph 5.19.1 and FIGURE 5-1 for more information.
3. Resolved dimensions must be permanently associated to the model values from which they were derived.

FIGURE 26-32 shows examples of basic resolved dimensions, directly toleranced resolved dimensions, and resolved limit dimensions.



Dimension Type	Basic Distance
Model Value	1.31250000
Units	inch
System Precision	8 decimal places
Displayed Precision	0.000
Resolved Dimension	1.312
As Shown on Drawing or Model	

Example 1

Dimension Type	Basic Radius
Model Value	0.8750000...0
Units	inch
System Precision	16 decimal places
Displayed Precision	0.00
Resolved Dimension	0.88
As Shown on Drawing or Model	

Example 2

Dimension Type	Basic Diameter
Model Value	50.15000000...0
Units	mm
System Precision	16 decimal places
Displayed Precision	0.0
Resolved Dimension	50.2
As Shown on Drawing or Model	

Example 3

Dimension Type	Basic Angle
Model Value	22.85315647°
Units	degrees
System Precision	8 decimal places
Displayed Precision	0.00
Resolved Dimension	22.85°
As Shown on Drawing or Model	

Example 4

Dimension Type	Distance
Tolerance Display	Equal-Bilateral
Model Value	1.31250000
Units	inch
System Precision	8 decimal places
Displayed Precision	0.000
Resolved Dimension	1.312
As Shown on Drawing or Model	

Example 5

Dimension Type	Radius
Tolerance Display	Unequal-Bilateral
Model Value	0.8750000...0
Units	inch
System Precision	16 decimal places
Displayed Precision	0.00
Resolved Dimension	0.88
As Shown on Drawing or Model	

Example 6

Dimension Type	Diameter
Tolerance Display	Unilateral
Model Value	50.15000000...0
Units	mm
System Precision	16 decimal places
Displayed Precision	0.0
Resolved Dimension	50.2
As Shown on Drawing or Model	

Example 7

Dimension Type	Angle
Tolerance Display	Limits
Model Value	22.85315647°
Units	degrees
System Precision	8 decimal places
Displayed Precision	0.00
Resolved Dimension	22.85°
As Shown on Drawing or Model	

Example 8

RESOLVED DIMENSION EXAMPLES
FIGURE 26-32



26.24 Queried Model Values. Unless specified otherwise, all undimensioned features and feature relationships are to be considered as basic dimensions; this is true on models, annotated models, and on drawings. Queried model values shall be considered as basic dimensions with the following exceptions:

1. If a feature or feature relationship is defined with a directly toleranced dimension or limit dimension.
2. If a feature or feature relationship is shown as a reference dimension.

26.25 Display of Basic Dimensions on Models and Drawings. Basic dimensions displayed on annotated models and drawings must be enclosed within a rectangular frame as defined in section 5 of the DRM. The definition of datum targets and the relationship between datum targets is an example where basic dimensions may need to be displayed. In cases where angles are close to 0°, 90°, 180°, 270°, or any orthogonal relationship, but are not orthogonal (e.g. 88.5°), the basic angle should be displayed.

26.26 Display of Directly Toleranced Dimensions and Limit Dimensions. If a feature or feature relationship is defined by a directly toleranced dimension or a limit dimension, such as a feature of size, the dimension and applicable tolerance(s) must be displayed. This applies to both annotated models and to drawings. This logic ties into paragraph 26.24 above, where it states “Unless specified otherwise, all undimensioned features and feature relationships are to be considered as basic dimensions.”

26.27 Expression of Directly Toleranced Dimensions and Limit Dimensions. The rules for the number of decimal places displayed, leading zeroes, and trailing zeroes shall be per paragraph 5.4.2.1 of the DRM.

26.28 Placing Dimensions and Tolerances on Annotation Planes. Basic dimensions, directly toleranced dimensions, limit dimensions, reference dimensions, etc. shall be located on an annotation plane that is coincident with or parallel to one of the planes of the appropriate model coordinate system. Dimensions and tolerances for inclined features or features on inclined surfaces are a possible exception, as they may reside on an annotation plane that is oriented to the inclined surface. See FIGURE 26-36. Dimensions and tolerances may be presented in chart or a tabulated format if desired.

26.29 Attaching Basic Dimensions and Directly Toleranced Dimensions to Annotated Models and Axonometric Drawing Views. Methods of attachment and format of basic dimensions and directly toleranced dimensions on annotated models and axonometric drawing views are shown in FIGURES 26-33 – 26-36. Rules for attaching dimensions and tolerances to specific feature types follow:

1. Surfaces. Dimensions defining surface geometry, such as form (shape), radii (fillets and rounds), chamfers, etc., must be directed to the surface with a leader. See FIGURES 26-34 and 26-35.
2. Features of Size: Attachment of size dimensions and tolerances are as follows:
 - a. Width Feature of Size [opposed parallel planes (keys, keyways, etc.)] The dimension and tolerance annotation for a width shall reside on an annotation plane that contains or is normal to the center plane of the feature. See FIGURES 26-34 – 26-36.
 - b. Cylindrical Feature of Size. The dimension and tolerance annotation for a cylindrical feature shall reside on an annotation plane that contains or is normal to the axis of the feature. See FIGURES 26-33 – 26-36.
 - c. Spherical Feature of Size. Dimension and tolerance annotation for a spherical feature shall reside on an annotation plane that contains the center point of the feature. See FIGURE 26-35.
3. Angles. Simple angles are dimensioned and toleranced as shown in FIGURES 26-35 and 26-36.
4. Countersinks and Counterbores. Several dimensioning and tolerancing options for countersinks and counterbores are shown in FIGURES 26-33 – 26-36. FIGURES 26-33a and b and 26-34c include options for how to specify the depth or remaining thickness of a counterbore.

Use and application of leaders shall conform to paragraph 26.19.4.4.

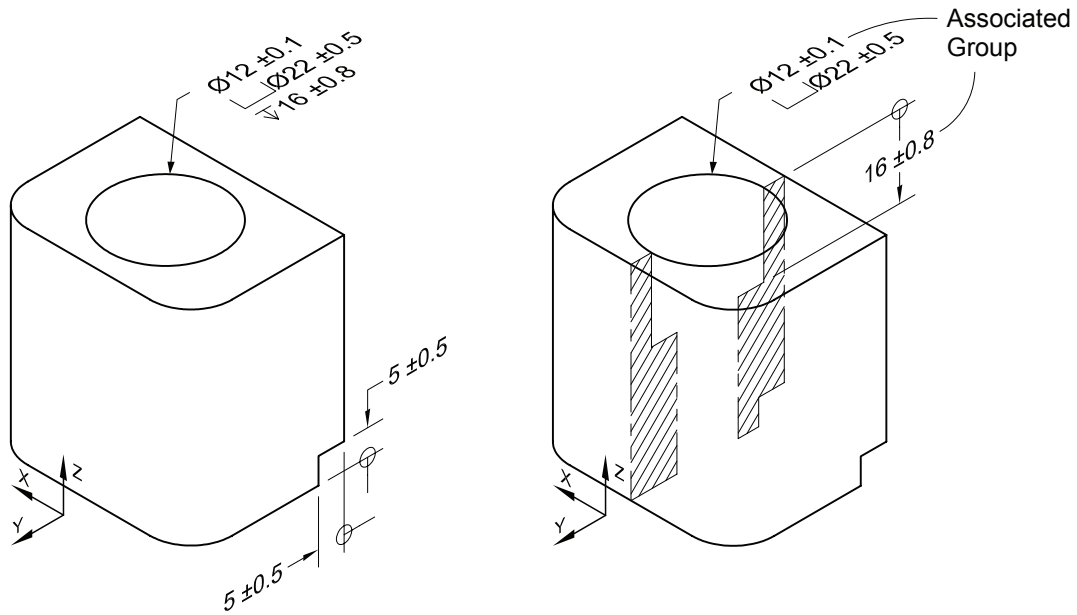

a. Notch and Traditional Counterbore Depth

b. Counterbore with Depth Specified Separately

ATTACHMENT OF DIMENSIONS AND TOLERANCES
FIGURE 26-33

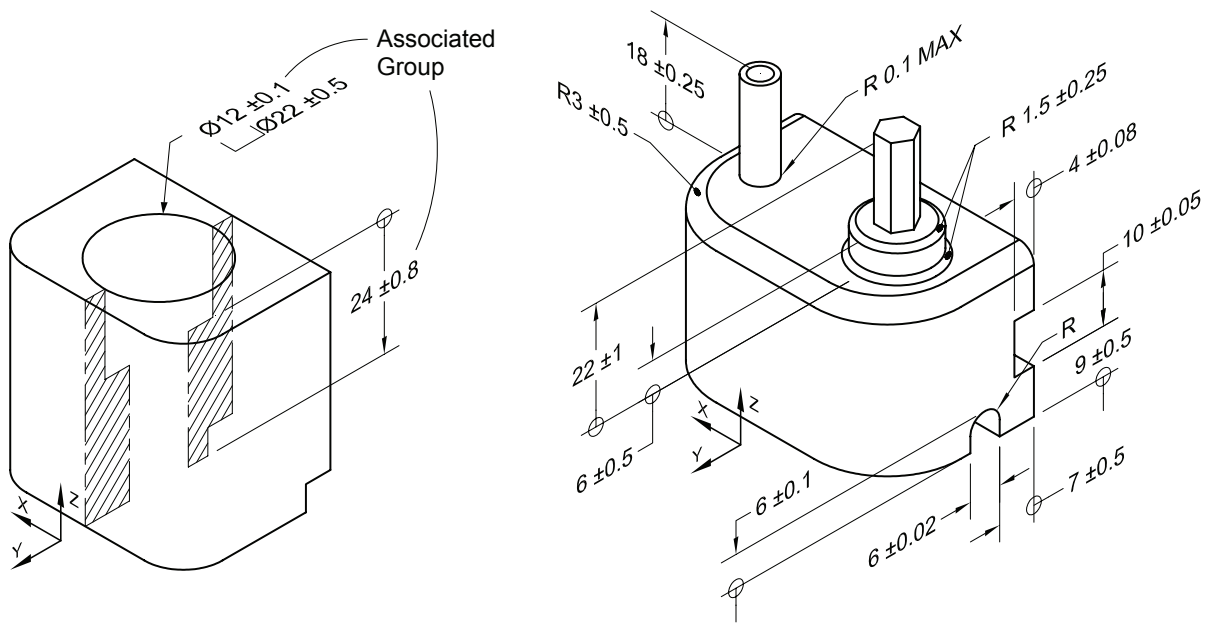

c. Counterbore with Remaining Thickness Specified

d. Notches and Protrusions with Dimension Origin Symbols, Features of Size, Fillets and Rounds

ATTACHMENT OF DIMENSIONS AND TOLERANCES
FIGURE 26-34

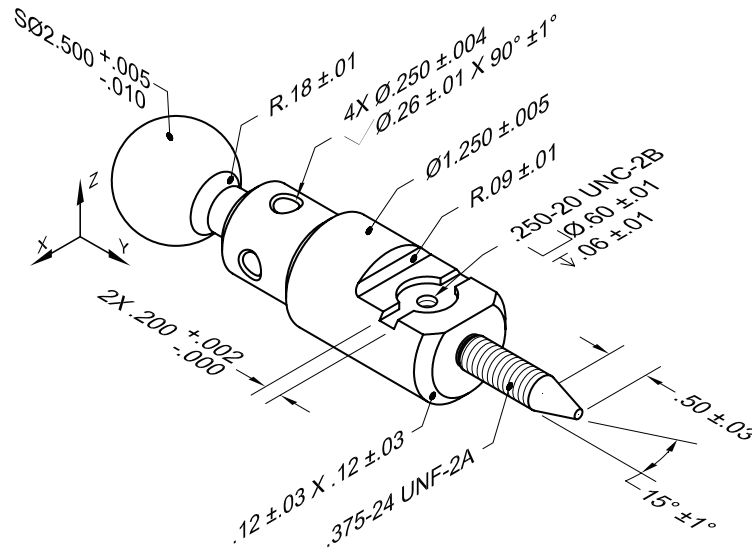

e. Features of Size, Countersinks, Chamfers, Fillets and Widths

ATTACHMENT OF DIMENSIONS AND TOLERANCES
 FIGURE 26-35

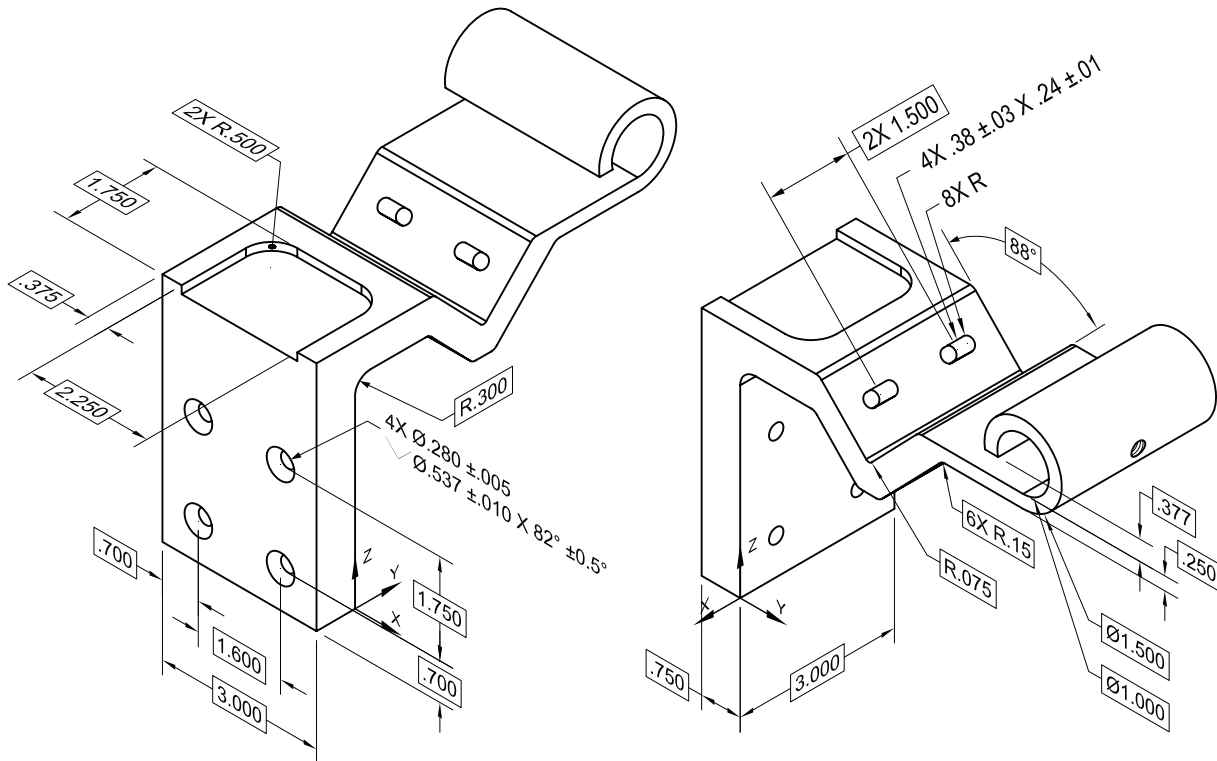

f. Basic Dimensions and Angled Surfaces

ATTACHMENT OF DIMENSIONS AND TOLERANCES
 FIGURE 26-36



26.30 Use and Applicability of Directly Toleranced Dimensions and Limit Dimensions. Directly toleranced dimensions and limit dimensions may be used and applied to annotated models or axonometric drawing views as defined in FIGURE 26-37. Examples of application and attachment methods are shown in FIGURES 26-33 – 26-36 and other figures throughout this section.

Feature Type	Attachment Method		
	Size Dimension and Tolerance	Leader Directed	Extension Lines
Features of Size	X		
Fillets, Rounds, Chamfers		X	
Reliefs, Stepped Surfaces			X
Countersinks	X		
Counterbores	X		
Oblique Surfaces			X
Depths, Spotfaces	X		
Remaining Thicknesses			X
Notches, Flats, Pin Heights			X

Note: Size dimensions and tolerances may be directed to the feature by a leader or by using extension and dimension lines as appropriate.

APPLICABILITY OF DIRECTLY TOLERANCED DIMENSIONS
 FIGURE 26-37

26.31 Datums and Datum Reference Frames. Rules for specification, display, and associativity for datum features, datum targets, and datum reference frames on models and axonometric drawing views are defined in these paragraphs. The requirements for and the use of model coordinate systems are also explained. Rules for querying datum features and datum targets are defined in paragraph 26.19.4.7.1.

26.31.1 Datum Reference Frame and Model Coordinate System Relationship on Annotated Models. Each datum reference frame defined on an annotated model must be associated to a unique model coordinate system that is not shared by other datum reference frames. By extension, if multiple datum reference frames are defined on an annotated model, each datum reference frame shall be associated to a unique model coordinate system. If queried, the relationship between a datum reference frame and its model coordinate system must be visually distinguishable from other datum reference frames and their model coordinate systems.

26.31.2 Datum Reference Frame and Model Coordinate System Relationship on Drawings. The rules for using and displaying model coordinate systems on drawings differ from the rules for their use and display on annotated models. The model coordinate system associated to each datum reference frame defined or referenced in an axonometric drawing view must be displayed in that axonometric view. [Note: A datum reference frame is defined by the datum features referenced in a feature control frame.] Although not required, it is a good idea to associate the feature control frame defining the datum reference frame to its model coordinate system. Currently, there are no rules or guidance in ASME Y14.41 for specifying, displaying, or using model coordinate system data on orthographic drawing views. However, there are many benefits to doing so as discussed in the following paragraph.

26.31.3 Benefits of Displaying Datum Reference Frame and Model Coordinate System Relationship on Models and Drawings. There are many benefits to displaying datum reference frames / model coordinate systems on annotated models and drawings. The most important benefits are that any query results for features related to a datum reference frame by geometric tolerances are given in the proper context to the datum reference frame, and the x, y, z coordinate values, angular relationships, and other values are clearly oriented



and located to the proper model coordinate system. See paragraph 26.22.1. Other benefits include the ability to correlate this information with downstream processes such as CNC manufacturing, coordinate metrology and any other processes that report data for features related to a datum reference frame. This is especially useful for QA / QC and measurement data reporting for features related to datum reference frames by geometric tolerances. [Note: A datum reference frame is essentially a Cartesian coordinate system, and the model coordinate system is a graphical representation of the datum reference frame on the model or drawing.]

26.31.4 Specifying Datum Features on Annotated Models and Axonometric Drawing Views. Methods of specifying and labeling datum features are shown in FIGURES 26-38 – 26-42. Datum features on annotated models and axonometric drawing views shall be identified by one of the following methods:

1. Attaching a datum feature symbol directly to the datum feature.
2. Attaching a datum feature symbol to a leader directed to the datum feature.
3. Attaching a datum feature symbol to the size dimension defining a datum feature of size.
4. Attaching a datum feature symbol to a feature control frame that controls the datum feature.

Note that the methods above do not apply to every application. For example, if a datum feature is not a feature of size, then method 3 would not apply. The following list defines which of the above methods may be applied to various types of datum features.

- a. Planar datum features may only be defined using method 1, 2, or 4 as applicable. Method 4 is preferred if a datum feature is composed of multiple planar surfaces. See FIGURES 26-38 – 26-42. Note the use of enlarged detail views on FIGURE 26-42 to clarify which surface is the datum feature.
- b. Cylindrical datum features of size may be defined using any of the methods above as applicable. See FIGURES 26-38 – 26-41.
- c. Spherical datum features of size may be defined using any of the methods above as applicable. See FIGURE 26-38.
- d. Width datum features of size [opposed parallel planes (keys, keyways, etc.)] may be defined using method 2, 3, or 4 as applicable. See FIGURES 26-38 – 26-41. The size dimension and tolerance controlling the datum feature and the datum feature symbol should be placed on an annotation plane that is normal to the center plane of the datum feature.
- e. Patterns of datum features of size should be defined using method 4. The datum feature symbol should be attached to the feature control frame that controls the relationship between the datum features. See FIGURES 26-39 and 26-41.
- f. Conical datum features may be defined using method 1, 2, or 4 as applicable. See FIGURES 26-38 and 26-20.
- g. Bounded datum features (closed linear extruded shapes) may be defined using method 2 or 4. Method 4 is preferred. If method 2 is used a grouping mechanism such as between points or the all-around symbol should be employed to clarify which set of surfaces make up the bounded feature. Method 4 is preferred as typically the feature control frame controlling the datum feature is applied on a between points or all-around basis. See FIGURES 26-39, 26-40 and 26-76.
- h. Complex or contoured datum features may be defined using method 1, 2, or 4. Method 4 is preferred. If method 2 is used a grouping mechanism such as between points or the all-around symbol may be needed to clarify which set of surfaces make up the feature. Method 4 is preferred as typically the feature control frame controlling the datum feature is applied on a between points or all-around basis. See FIGURE 26-42.
- i. Multiple datum features may be defined using any of the methods above as applicable. Method 4 is preferred, it would be clearest to define the datum features by attaching the datum feature symbol to the feature control frame that control the relationship of the features to one another. See datum feature B-C in FIGURE 26-41 and datum feature A-B in FIGURES 26-54 and 26-55.



- j. Repetitive datum features referenced on an individual basis may be defined using any of the methods above as applicable. Use the method that most clearly defines the datum features and their relationship one another. See datum feature E in FIGURE 26-41.

26.31.5 Specifying Datum Targets on Annotated Models and Axonometric Drawing Views. General methods of specifying and labeling datum targets are shown in FIGURES 26-43 – 26-45. Unlike datum features, where the entire feature is used as the datum feature, datum targets are typically used where only a portion of a feature is used to establish a datum. Datum targets may be points, lines, curves, areas, or any combination of these, and may be applied to any type of feature. Also different from datum features, datum target specifications not only include a datum target symbol, but also include supplemental geometry depicting the shape of the target (point, line, area) and its location, and sometimes its orientation and form as well. In some cases, the datum target simulator may even be a completely different shape than the feature, such as the case where V-type equalizers or tooling balls are used as datum target simulators. Partial datum features are similar to datum targets, but are specified as a datum feature and not as a datum target. See datum feature D in FIGURES 26-39 and 26-40 for an example of a partial datum feature specification.

Datum targets are specified using a datum target symbol, a leader (typically without an arrowhead), and geometry depicting the shape of the target. As stated above, targets may be any shape. Hidden line leaders to depict datum targets on hidden surfaces are not allowed on annotated models; their use is optional on axonometric drawing views. FIGURES 26-43 – 26-45 show various applications of datum target specifications.

1. A datum target point is depicted using a target point symbol (see datum target C1 in FIGURE 26-43 and datum targets C1 and C2 in FIGURES 26-54 and 26-55).
2. The shape of a datum target line is depicted using a phantom line of the desired shape and length (see datum target A2 in FIGURE 26-45 and datum target B1 in FIGURES 26-54 and 26-55).
3. The shape of a datum target area is depicted using a phantom line of the desired shape and size, filled in with section lines (see datum targets A1, A2, A3, B1, and B2 in FIGURE 26-43). Non-circular datum target areas should be shown and dimensioned on the model or drawing view. See datum target A1 in FIGURE 26-45 for an example of a rectangular datum target area on an annotated model. It is a good idea to dimension the sizes of the area as shown, as it may not be visually obvious which side is longer or shorter (28mm or 25mm in this example). Dimensions may be omitted on annotated models, as the dimensions of the target area must be available through query.

Note that the methods above do not apply to every application. V-type equalizers, tooling balls, and movable datum target symbols are not shown in these figures. See paragraph 5.12 and subparagraphs in the DRM for more information on the use of datum targets and the rules for specifying datum targets on orthographic drawing views.

26.31.6 Associativity of Datum Feature Symbols to Related Data on Annotated Models. Datum feature symbols must be associated to the datum feature(s) to which they are applied, any dimensions and tolerances that control the datum feature (including geometric tolerances), the model coordinate system to which the datum feature's controlling geometric tolerance is related (if applicable), and the model coordinate system(s) associated to any datum reference frame that references the datum feature.

26.31.7 General Comments on Specifying Datum Features and Datum Targets. Datum features and datum targets should be specified in such a manner that ensures it is clear which features or portions of features are to be used to establish the datums. On axonometric drawing views all of the information should be visually displayed in the view, aside from any data that must be obtained from the model, such as the size, form, orientation or location of undimensioned datum features. In these cases, the model must be available for query to obtain the missing information. On annotated models, query should be used to obtain a complete set of the required information to ensure full understanding of datum feature and datum target specifications. Proper annotation, associativity, highlighting, and saved views will ensure all components related to a datum feature or datum target is clear. Datum features and datum targets may be specified and used together to construct a datum reference frame on the same model or drawing if desired. In fact, multiple datum features may be a combination of datum features and datum targets where design function or setup requirements dictate.

See datum feature A-B on FIGURES 26-54 and 26-55 for an example of such a multiple datum feature. The primary datum feature is a combination of datum feature A, which is a flat surface on the underside of the part, and datum target line B1, which is a straight line that extends across two surfaces on the undersides of the part. A-B is the primary datum feature.

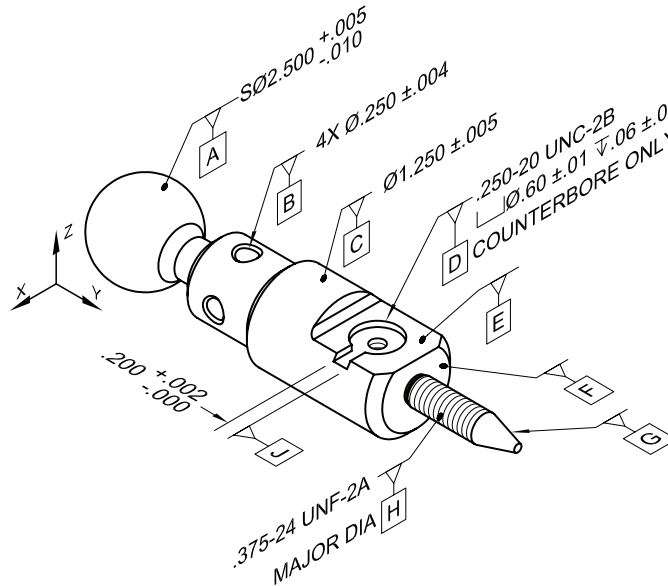

a. Leader and Size Dimension Attachment

SPECIFYING DATUM FEATURES AND ATTACHING DATUM FEATURE SYMBOLS
 FIGURE 26-38

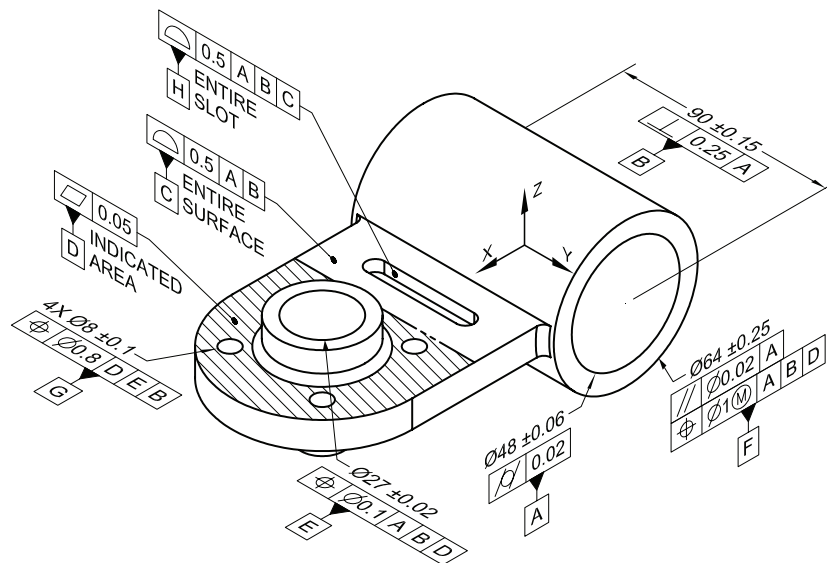

b. Feature Control Frame Attachment

SPECIFYING DATUM FEATURES AND ATTACHING DATUM FEATURE SYMBOLS
 FIGURE 26-39

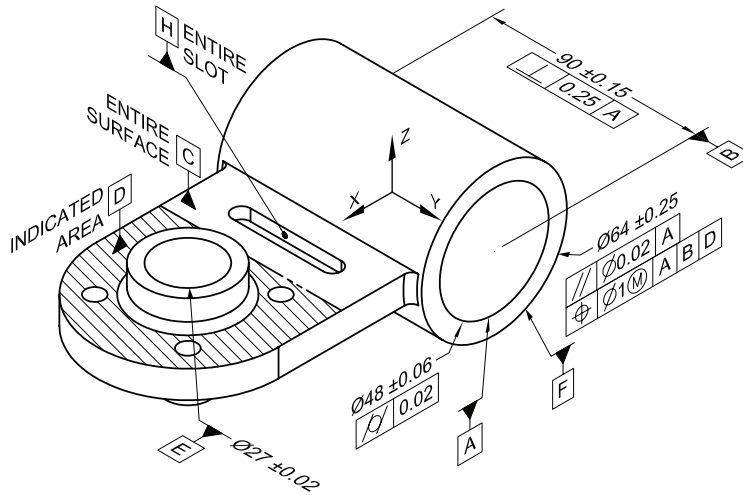

c. Leader, Size Dimension and Direct Attachment

SPECIFYING DATUM FEATURES AND ATTACHING DATUM FEATURE SYMBOLS
FIGURE 26-40

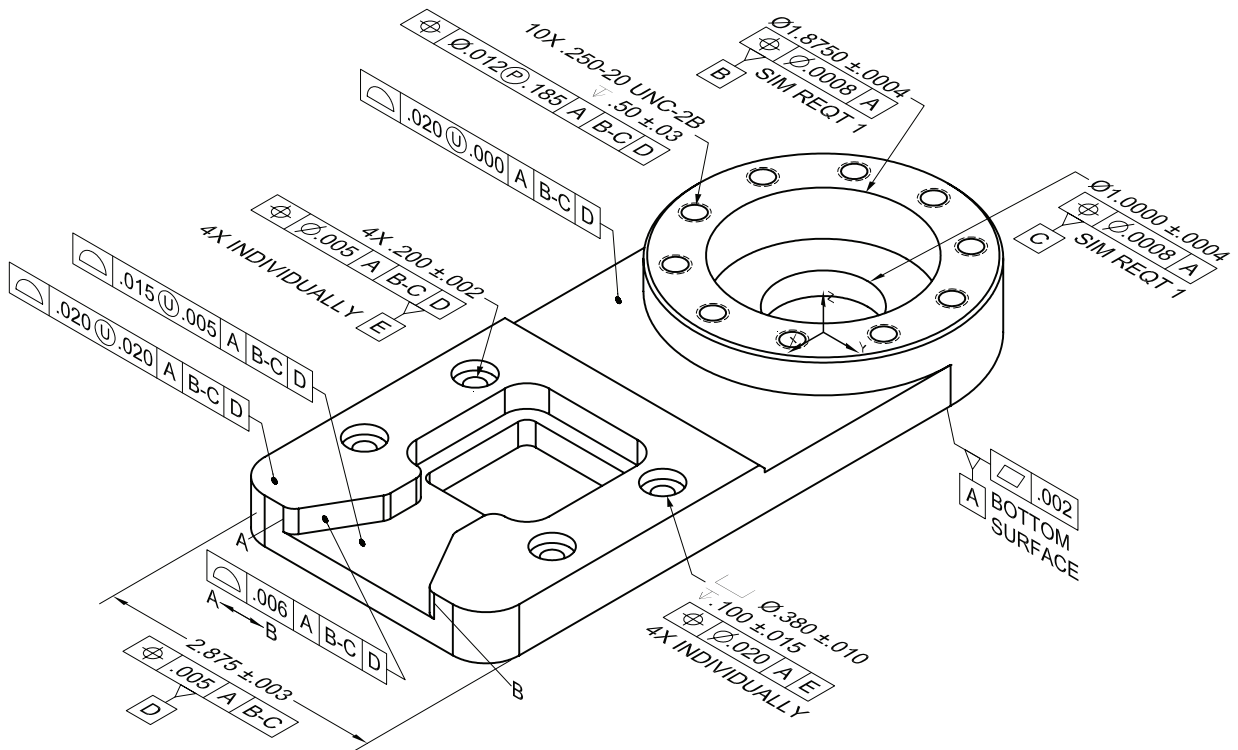

d. Multiple Datum Features and Repetitive Datum Features

(Note: Model coordinate systems for repetitive datum reference frame A, E not shown.)

SPECIFYING DATUM FEATURES AND ATTACHING DATUM FEATURE SYMBOLS
FIGURE 26-41

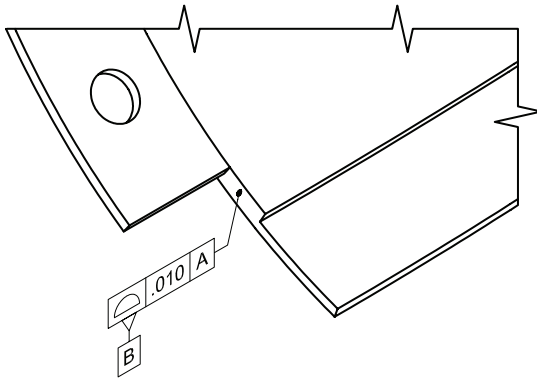

DETAIL VIEW OF DATUM FEATURE B

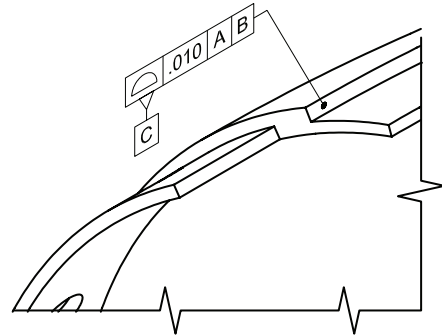

DETAIL VIEW OF DATUM FEATURE C

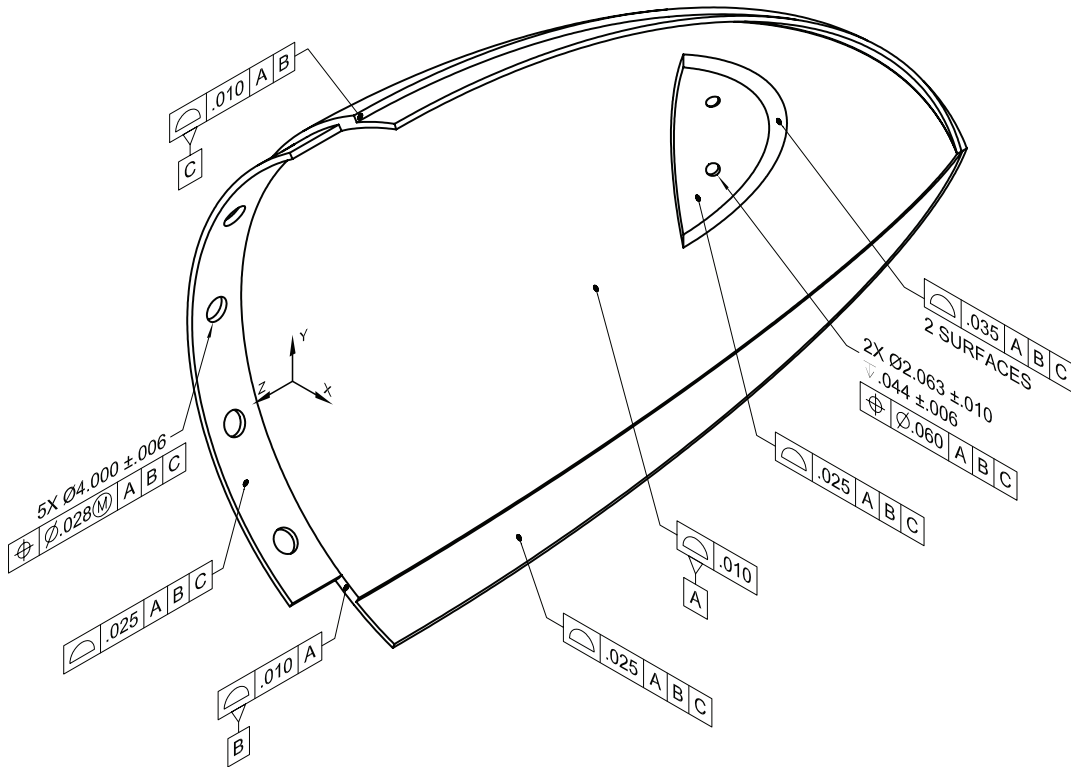

e. Complex Surface Datum Feature with Overconstraining Datum Features

Note: When datum feature A is brought into contact with its datum feature simulator, 6 degrees of freedom are eliminated, so technically datum features B & C are not needed. However, sometimes where parts are flexible or the contour of the primary datum feature is relatively shallow, such that the degrees of freedom are inadequately constrained or eliminated by the primary datum feature simulator, it is common to reference additional datum features to more completely constrain the part. In effect datum features B & C in the above example provide redundant constraint of some of the degrees of freedom restricted by datum feature A. In such cases we refer to these theoretically redundant datum features as providing overconstraint.

SPECIFYING DATUM FEATURES AND ATTACHING DATUM FEATURE SYMBOLS

FIGURE 26-42

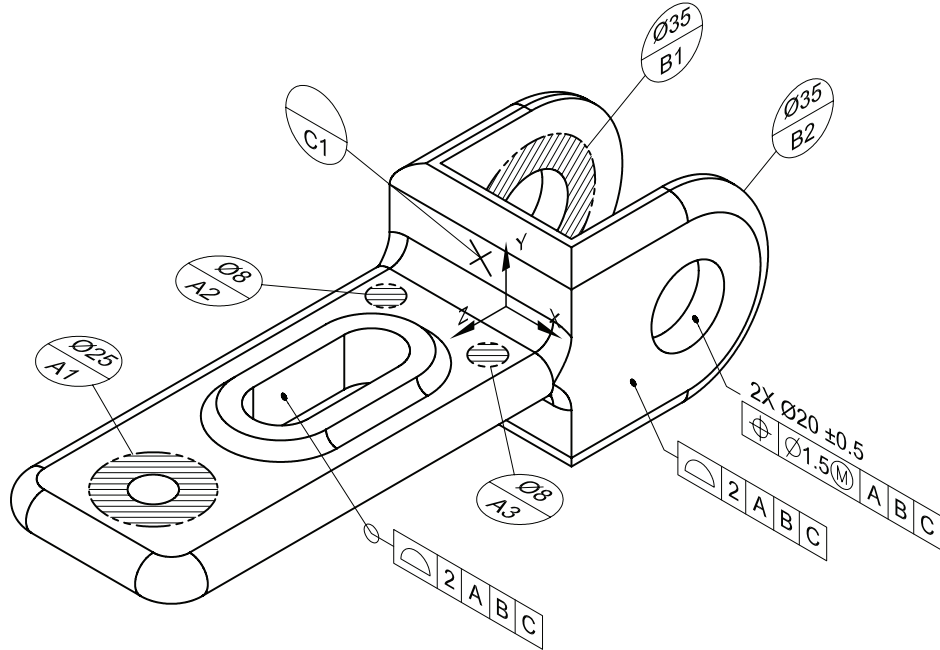

a. Datum Target Specification and Attachment Options

SPECIFYING DATUM TARGETS AND ATTACHING DATUM TARGET SYMBOLS
FIGURE 26-43

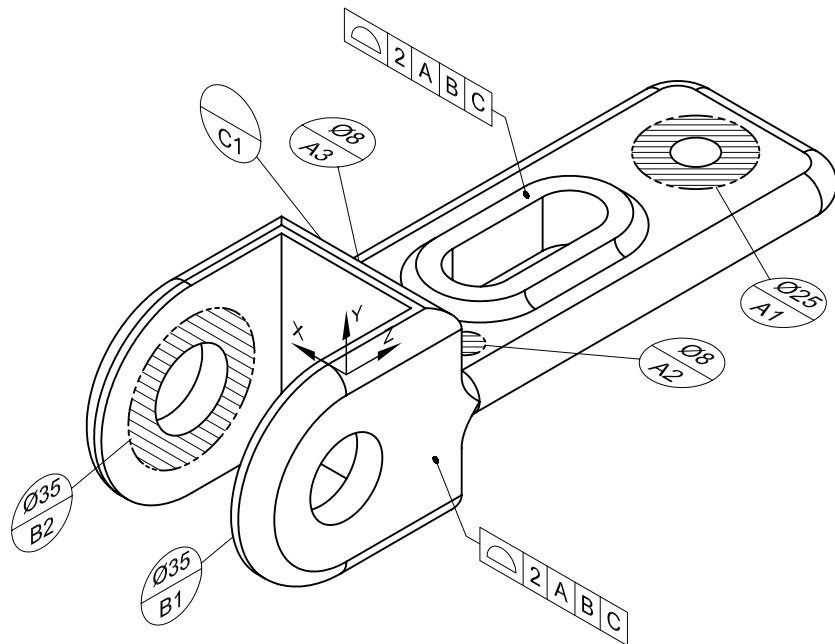

b. Datum Target Specification and Attachment Options

SPECIFYING DATUM TARGETS AND ATTACHING DATUM TARGET SYMBOLS
FIGURE 26-44

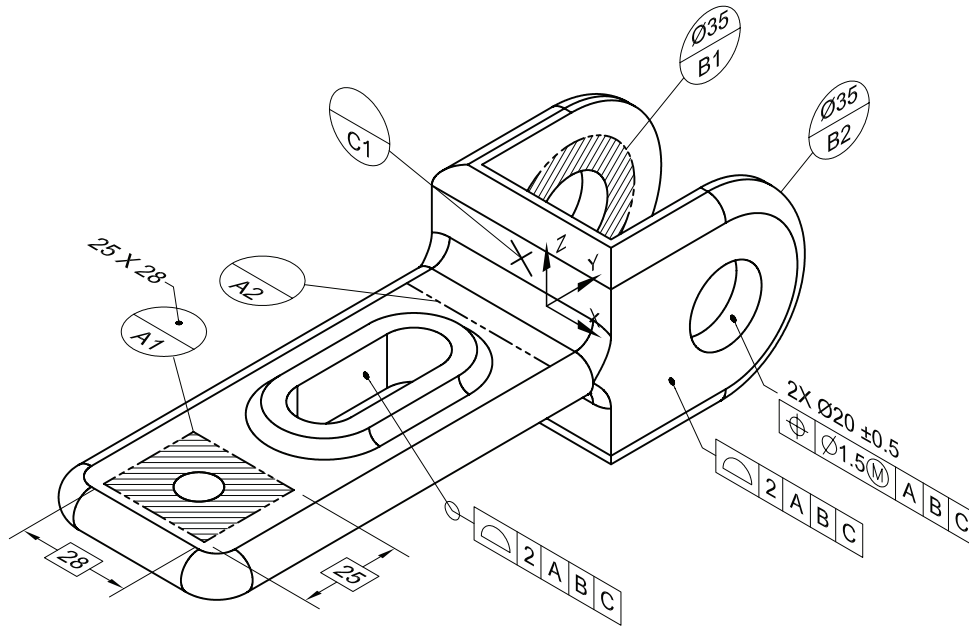

c. Datum Target Specification and Attachment Options

SPECIFYING DATUM TARGETS AND ATTACHING DATUM TARGET SYMBOLS
 FIGURE 26-45

26.32 Annotating Assemblies on Annotated Models and Axonometric Drawing Views. These paragraphs provide guidance for and examples of annotating separable and inseparable assemblies in annotated assembly models and on axonometric drawing views. Further guidance and rules for annotating assemblies and parts lists may be found in the applicable ASME standards and in Sections 4, 7, and 10 of the DRM.

26.32.1 Specifying Item Numbers on Annotated Models and Axonometric Drawing Views. Item numbers shall be specified using methods defined in ASME Y14.100 and paragraph 7.11 and subparagraphs of the DRM. (Note that the DRM also refers to item numbers as *find numbers*.) Item number balloons shown on annotated models shall be placed on one or more annotation planes that rotate with the model. Item number balloons shown on axonometric drawing views shall be placed on one or more annotation planes that are oriented to the model. See FIGURES 26-46 – 26-51. All assembly annotation shown in orthographic drawing views shall adhere to existing standards for orthographic drawings.

26.32.2 Parts Lists Related to Annotated Models and Axonometric Drawing Views. A parts list applied to an annotated model shall be located on the general annotation plane that does not rotate with the model. A parts list on a drawing shall be parallel to the plane of the drawing and meet the rules for parts lists on orthographic drawings, regardless of whether the item number balloons are specified in axonometric drawing views, orthographic drawing views, or a combination of both. Regardless of where it is located, part list format and content shall adhere to Section 10 of the DRM. See FIGURES 26-46 – 26-51. Note that simplified parts lists have been used on these figures.

26.32.3 Separable Assemblies on Annotated Models and Axonometric Drawing Views. FIGURE 26-46 shows an annotated model of a separable assembly and its parts list. FIGURE 26-47 shows a drawing with axonometric and orthographic views of a separable assembly and its parts list. See Section 4 of the DRM and FIGURE 4-59 for more information on separable assemblies and separable assembly drawings.

26.32.4 Inseparable Assemblies on Annotated Models and Axonometric Drawing Views. FIGURES 26-48 and 26-50 show annotated models of inseparable assemblies and their parts list. FIGURES 26-49 and 26-51 show drawings with an axonometric view of each respective inseparable assembly and its parts list. See

Section 4 of the DRM and FIGURE 4-29 for more information on inseparable assemblies and inseparable assembly drawings.

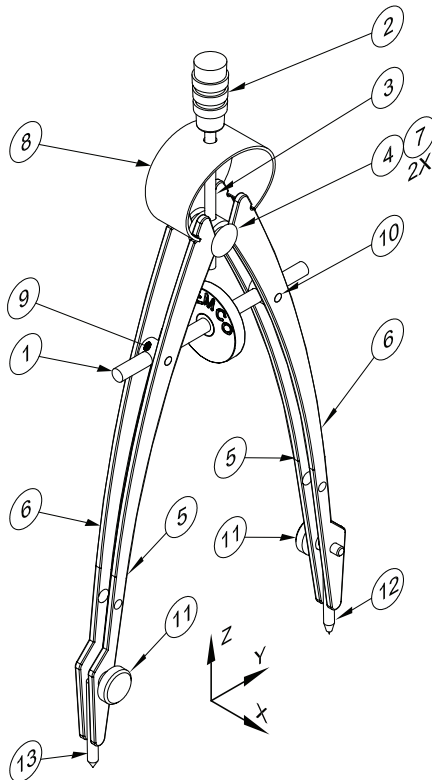

PARTS LIST				
ITEM	QTY	PART NO	REV	DESCRIPTION
1	1	113507-002	A	ASSY, THUMB WHEEL
2	1	113501-001	A	NUT, ROTATOR
3	1	113504-001	A	SHAFT, ROTATOR
4	1	113506-001	A	PIN, PIVOT
5	2	113502-001	A	LEG, CLEAR
6	2	113508-001	A	LEG, THREADED
7	2	113505-001	A	CAP, PIVOT PIN
8	1	113503-001	A	SPRING, PIVOT
9	1	113509-001	A	NUT, CAPTIVE, LH
10	1	113510-001	A	NUT, CAPTIVE, RH
11	2	113512-001	A	SCREW, GRIP, KNURLED
12	1	11000-001	C	POINTER
13	1	11001-001	E	LEAD, 2mm, 2H

ASSY, COMPASS, 6" SWING RADIUS

113500-002 REV A

SEPARABLE ASSEMBLY – ANNOTATED MODEL WITH PARTS LIST
 FIGURE 26-46

26.33 Geometric Tolerancing on Annotated Models and Axonometric Drawing Views. These paragraphs provide guidance, additional rules, restrictions, new tools and techniques for specifying geometric tolerances on annotated models and axonometric drawing views. Note that this section does not contain examples of every geometric tolerance or every application of geometric tolerancing. Sufficient examples are included to provide guidance and highlight the new rules, techniques, and restrictions for specifying geometric tolerances on 3D annotated models and axonometric drawing views.

26.33.1 General Rules for Specifying Geometric Tolerances on Axonometric Drawing Views. The following rules apply to geometric tolerances specified on axonometric drawing views; these rules do not apply to geometric tolerances specified on annotated models.

1. **Feature Visibility.** As a minimum requirement, if a geometric tolerance is specified in an axonometric drawing view, a portion of the toleranced feature must be visible in the view. Exceptions are where the geometric tolerance is specified in another axonometric drawing view and the feature control frame in the view is redundant.
2. **Geometric Tolerances Controlling the Center Geometry of Features of Size.** Geometric tolerances controlling the center geometry of a feature of size must be associated to and located just below the size dimension and tolerance. Center geometry controlled: [Position: center point, axis, or center plane]; [Straightness: derived median line or derived median plane]; [Concentricity: median points]; [Symmetry: median points].
3. **Geometric Tolerances Specified on a Boundary Basis.** Positional tolerances and orientation tolerances controlling a feature of size or bounded feature using the notation BOUNDARY must be associated to and located just below the size dimension and tolerance. In addition, the notation BOUNDARY must be located adjacent to the position or orientation tolerance feature control frame.



4. Geometric Tolerances Controlling a Surface. Geometric tolerances controlling a surface and not the center geometry of a feature of size or a bounded feature must be directed to the surface with a leader that terminates in a dot. See paragraph 26.19.4.4.2 for more information.

26.33.2 Specifying Default (or Global) Geometric Tolerances. Default geometric tolerances may be specified in a general note or in a tolerance block. See FIGURES 26-54 and 26-55 for examples.

If default geometric tolerances are specified on an annotated model, they should be specified on an annotation plane that does not rotate with the model. The default tolerances must be available by query and / or reside in a saved view. See FIGURE 26-54.

If default geometric tolerances are specified on an axonometric drawing view, the default geometric tolerances should be specified with the general notes or in the tolerance block on the drawing. See FIGURE 26-55.

In both situations the default tolerances may be located somewhere else within the dataset, such as in a referenced file, on a referenced drawing, or in a separate list or standard as applicable.

26.33.3 Form Tolerances on Annotated Models and Axonometric Drawing Views. Form tolerance feature control frames and associated annotation must reside on an annotation plane that is coincident with, parallel to, or perpendicular to the toleranced feature. Depending on the type of feature being controlled, form tolerance feature control frames may be attached to a leader directed to a surface or attached to a size dimension. Form tolerances controlling single flat surfaces or straight line elements on a surface must be attached to a leader directed to the surface. Circularity and cylindricity tolerances also control surface elements, but may be attached to the size dimension for a feature of size. A straightness tolerance that controls the derived median line or derived median plane of a feature of size must be attached to or specified with the size dimension for the feature of size. Note that in most cases form tolerances are refinements of other form-affecting tolerances, such as size tolerances, profile, runout, or orientation tolerances. Examples of form tolerances as refinements of other tolerances may be seen in many of the figures listed below. See the following figures for examples of form tolerances applied to annotated models and axonometric drawing views.

1. Flatness. Examples of flatness tolerances applied to annotated models and axonometric drawing views can be seen in FIGURES 26-5, 26-18, 26-19 – 26-26, 26-39, 26-41, 26-52, 26-53, 26-54, and 26-55. FIGURE 26-18 and 26-39 show examples of flatness applied within a limited area. Many of these figures show flatness as a refinement of other geometric tolerances.
2. Circularity (Roundness). Examples of circularity tolerances applied to annotated models and axonometric drawing views can be seen in FIGURES 26-52 and 26-53.
3. Cylindricity. Examples of cylindricity tolerances applied to annotated models and axonometric drawing views can be seen in FIGURES 26-18, 26-39, 26-52, 26-53, and 26-56 – 26-58.
4. Straightness. Examples of straightness tolerances applied to annotated models and axonometric drawing views can be seen in FIGURES 26-3, 26-4, 26-19 – 26-26, and 26-53. FIGURE 26-53 includes an example of straightness controlling the derived median line of a feature of size.

26.33.3.1 Flatness Tolerances Applied to a Limited Area on Annotated Models and Axonometric Drawing Views. The limited area must be defined using supplemental geometry. The flatness feature control frame must be attached to a leader that terminates within the limited area or on the boundary of the area provided the specification is clear. Rules for leaders as stated in paragraph 26.19.4.4 must be followed. Examples of flatness applied within a limited area may be seen in FIGURES 26-18 and 26-39.

26.33.3.2 Straightness Tolerances Applied to Line Elements of a Surface on Annotated Models and Axonometric Drawing Views. When applying a straightness tolerance to line elements on a surface, it is best practice to model the line element as supplemental geometry and display it on the model or drawing. Although not mandatory, it is a good idea to add a local note to the feature control frame stating EACH ELEMENT, further clarifying that the tolerance applies to line elements on the surface. If the line element is shown, the straightness feature control frame must be attached to a leader that terminates on the line element.

If the line element is not modeled or shown, the direction of application is indicated by the orientation of the feature control frame and its associated annotation to the associated model coordinate system; the feature control frame, leader, and associated annotation must reside on an annotation plane parallel to the desired direction of application. See paragraph 26.14.3.1 for more information. Examples of straightness tolerances applied to line elements may be seen in FIGURES 26-3, 26-19 – 26-26, and 26-53.

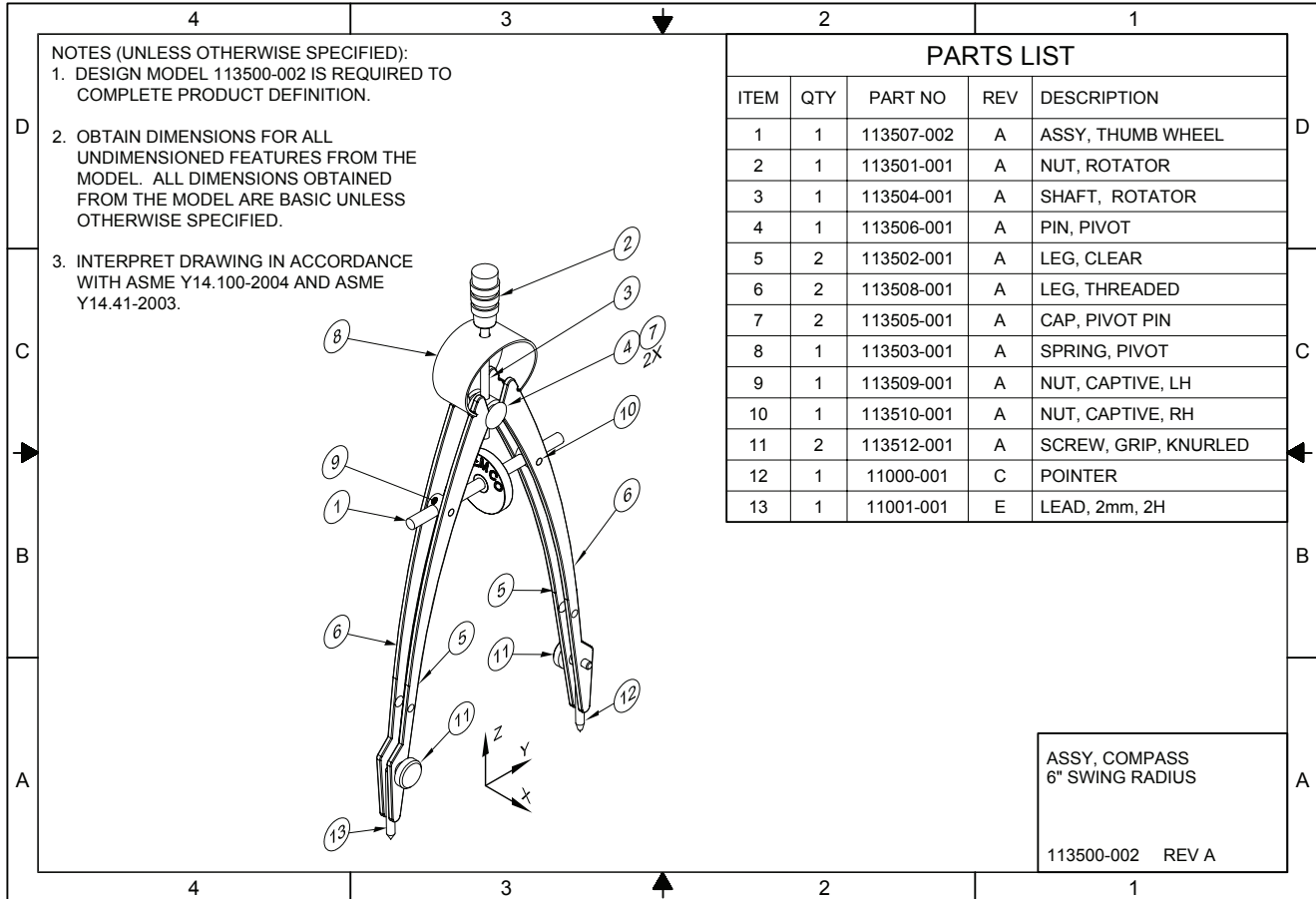

SEPARABLE ASSEMBLY – DRAWING WITH PARTS LIST
FIGURE 26-47

26.33.4 Orientation Tolerances on Annotated Models and Axonometric Drawing Views. Orientation tolerance (angularity, parallelism, and perpendicularity) feature control frames and associated annotation must reside on an annotation plane that is coincident with, parallel to, or perpendicular to the primary datum feature referenced in the feature control frame. Depending on the type of feature being controlled, orientation tolerance feature control frames may be attached to a leader directed to a surface, attached to a size dimension, or attached to a dimension line as shown in FIGURE 26-58. Orientation tolerances controlling single flat surfaces or straight line elements on a surface must be attached to a leader directed to the surface. Orientation tolerance feature control frames controlling the axis of a cylindrical feature of size or the center plane of a width feature of size should be attached to or specified with the size dimension for a feature of size. Note that in most cases orientation tolerances are refinements of other geometric tolerances, such as location, profile, or runout tolerances. Orientation tolerances are specified as refinements of other tolerances in many of the figures listed below. Examples of orientation tolerances applied to annotated models and axonometric drawing views are shown in FIGURES 26-1, 26-3, 26-4, 26-9, 26-10, 26-13, 26-14, 26-15, 26-18, 26-30, 26-39, 26-40, 26-52, 26-53, and 26-56 – 26-58.

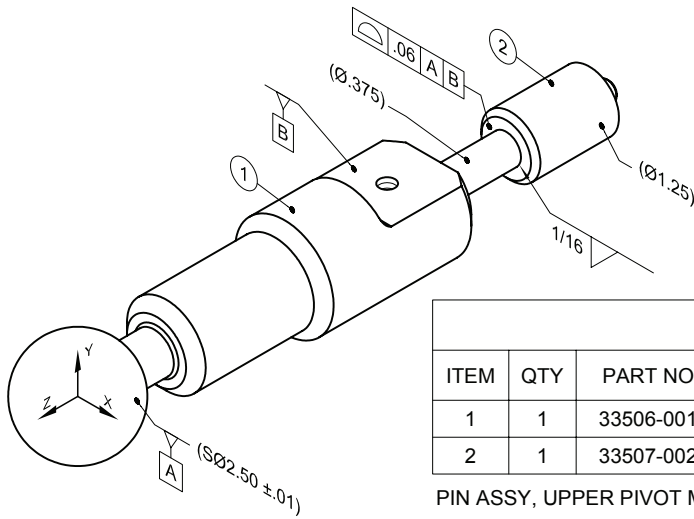

PARTS LIST				
ITEM	QTY	PART NO	REV	DESCRIPTION
1	1	33506-001	A	PIN BODY, UPPER PIVOT MOUNT
2	1	33507-002	C	SLEEVE, UPPER PIVOT MOUNT PIN

PIN ASSY, UPPER PIVOT MOUNT 33505-001 REV B

INSEPARABLE ASSEMBLY 1 – ANNOTATED MODEL WITH PARTS LIST
FIGURE 26-48

	4	3	2	1															
D	NOTES (UNLESS OTHERWISE SPECIFIED): 1. DESIGN MODEL 33505-001 IS REQUIRED TO COMPLETE PRODUCT DEFINITION. 2. OBTAIN DIMENSIONS FOR ALL UNDIMENSIONED FEATURES FROM THE MODEL. ALL DIMENSIONS OBTAINED FROM THE MODEL ARE BASIC UNLESS OTHERWISE SPECIFIED. 3. INTERPRET DRAWING IN ACCORDANCE WITH ASME Y14.5-1994, ASME Y14.41-2003 AND ASME Y14.100-2004.		PARTS LIST																
			<table border="1"> <thead> <tr> <th>ITEM</th> <th>QTY</th> <th>PART NO</th> <th>REV</th> <th>DESCRIPTION</th> </tr> </thead> <tbody> <tr> <td>1</td> <td>1</td> <td>33506-001</td> <td>A</td> <td>PIN BODY, UPPER PIVOT MOUNT</td> </tr> <tr> <td>2</td> <td>1</td> <td>33507-002</td> <td>C</td> <td>SLEEVE, UPPER PIVOT MOUNT PIN</td> </tr> </tbody> </table>		ITEM	QTY	PART NO	REV	DESCRIPTION	1	1	33506-001	A	PIN BODY, UPPER PIVOT MOUNT	2	1	33507-002	C	SLEEVE, UPPER PIVOT MOUNT PIN
	ITEM	QTY	PART NO	REV	DESCRIPTION														
1	1	33506-001	A	PIN BODY, UPPER PIVOT MOUNT															
2	1	33507-002	C	SLEEVE, UPPER PIVOT MOUNT PIN															
C																			
B																			
A			<table border="1"> <tr> <td colspan="2">PIN ASSY, UPPER PIVOT MOUNT</td> </tr> <tr> <td>33505-001</td> <td>REV B</td> </tr> </table>		PIN ASSY, UPPER PIVOT MOUNT		33505-001	REV B											
PIN ASSY, UPPER PIVOT MOUNT																			
33505-001	REV B																		
	4	3	2	1															

INSEPARABLE ASSEMBLY 1 – DRAWING WITH PARTS LIST
FIGURE 26-49

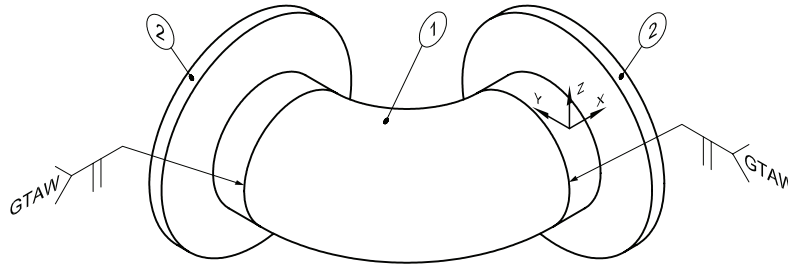

PARTS LIST				
ITEM	QTY	PART NO	REV	DESCRIPTION
1	1	KF-32-F-P	A	FTG, WELD STUB, SHORT, 2", UH VACUUM
2	2	KF-32-E90-P	A	ELL, 90°, 2", UH VACUUM

ASSY, ELL, 90°, 2", KF, ULTRA HIGH VACUUM 28646-001 REV A

INSEPARABLE ASSEMBLY 2 – ANNOTATED MODEL WITH PARTS LIST
FIGURE 26-50

4	3	2	1																				
<p>NOTES (UNLESS OTHERWISE SPECIFIED):</p> <p>1. DESIGN MODEL 28646-001 IS REQUIRED TO COMPLETE PRODUCT DEFINITION.</p> <p>2. OBTAIN DIMENSIONS FOR ALL UNDIMENSIONED FEATURES FROM THE MODEL. ALL DIMENSIONS OBTAINED FROM THE MODEL ARE BASIC UNLESS OTHERWISE SPECIFIED.</p> <p>3. INTERPRET DRAWING IN ACCORDANCE WITH ASME Y14.5-1994, ASME Y14.41-2003 AND ASME Y14.100-2004.</p> <p>4. WELDING PER SPEC. 123-001-B_2.</p>	<table border="1"> <thead> <tr> <th colspan="5">PARTS LIST</th> </tr> <tr> <th>ITEM</th> <th>QTY</th> <th>PART NO</th> <th>REV</th> <th>DESCRIPTION</th> </tr> </thead> <tbody> <tr> <td>1</td> <td>1</td> <td>KF-32-F-P</td> <td>A</td> <td>FTG, WELD STUB, SHORT, 2", UH VACUUM</td> </tr> <tr> <td>2</td> <td>2</td> <td>KF-32-E90-P</td> <td>A</td> <td>ELL, 90°, 2", UH VACUUM</td> </tr> </tbody> </table>			PARTS LIST					ITEM	QTY	PART NO	REV	DESCRIPTION	1	1	KF-32-F-P	A	FTG, WELD STUB, SHORT, 2", UH VACUUM	2	2	KF-32-E90-P	A	ELL, 90°, 2", UH VACUUM
	PARTS LIST																						
	ITEM	QTY	PART NO	REV	DESCRIPTION																		
	1	1	KF-32-F-P	A	FTG, WELD STUB, SHORT, 2", UH VACUUM																		
2	2	KF-32-E90-P	A	ELL, 90°, 2", UH VACUUM																			
			<table border="1"> <tr> <td>ASSY, ELL, 90°, 2", KF ULTRA HIGH VACUUM</td> </tr> <tr> <td>28646-001 REV A</td> </tr> </table>	ASSY, ELL, 90°, 2", KF ULTRA HIGH VACUUM	28646-001 REV A																		
ASSY, ELL, 90°, 2", KF ULTRA HIGH VACUUM																							
28646-001 REV A																							
4	3	2	1																				

INSEPARABLE ASSEMBLY 2 – DRAWING WITH PARTS LIST
FIGURE 26-51

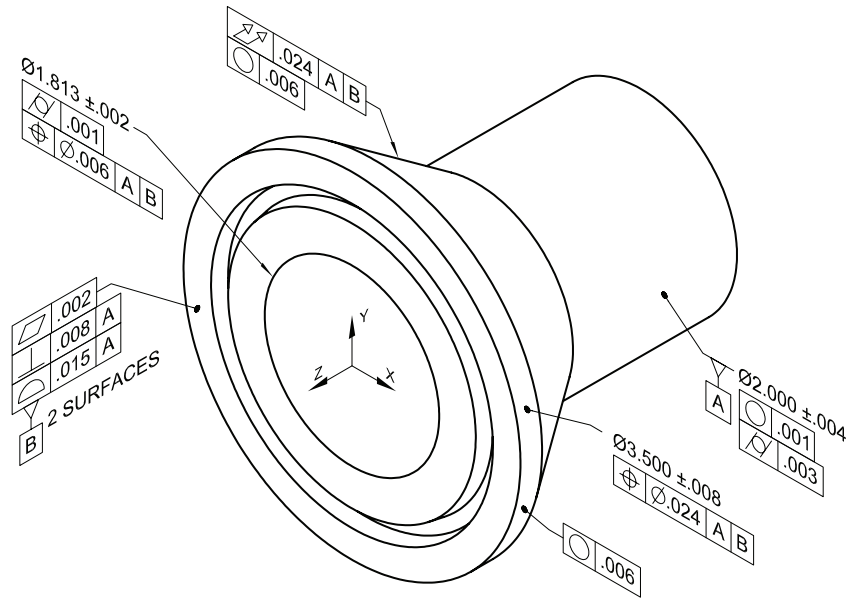

FORM TOLERANCES APPLIED TO AN ANNOTATED MODEL 1
FIGURE 26-52

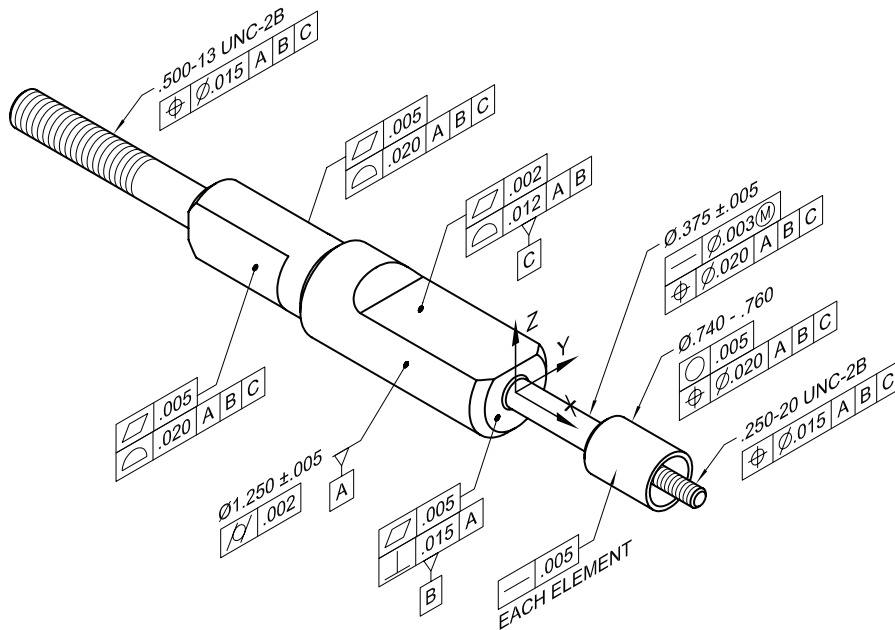

FORM TOLERANCES APPLIED TO AN ANNOTATED MODEL 2
FIGURE 26-53

NOTES (UNLESS OTHERWISE SPECIFIED):

1. OBTAIN DIMENSIONS FOR ALL UNDIMENSIONED FEATURES FROM THE MODEL. ALL DIMENSIONS OBTAINED FROM THE MODEL ARE BASIC UNLESS OTHERWISE SPECIFIED.
2. TOLERANCE FOR ALL UNTOLERANCED SURFACES =

	.010	A-B	C
--	------	-----	---
3. INTERPRET IN ACCORDANCE WITH ASME Y14.5M-1994, ASME Y14.41-2003 AND ASME Y14.100-2004.

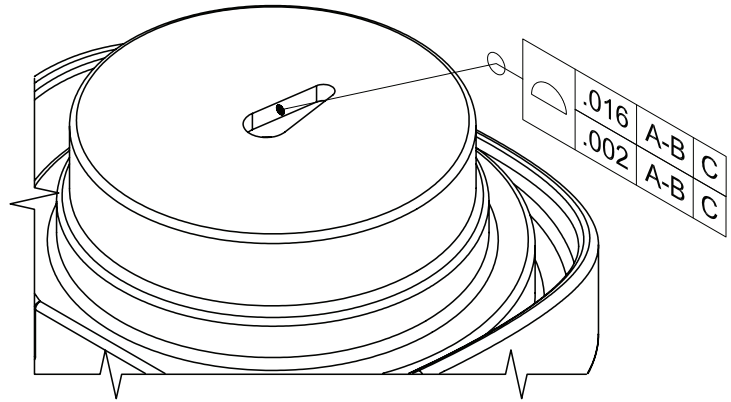

DETAIL VIEW OF TAPERED SLOT

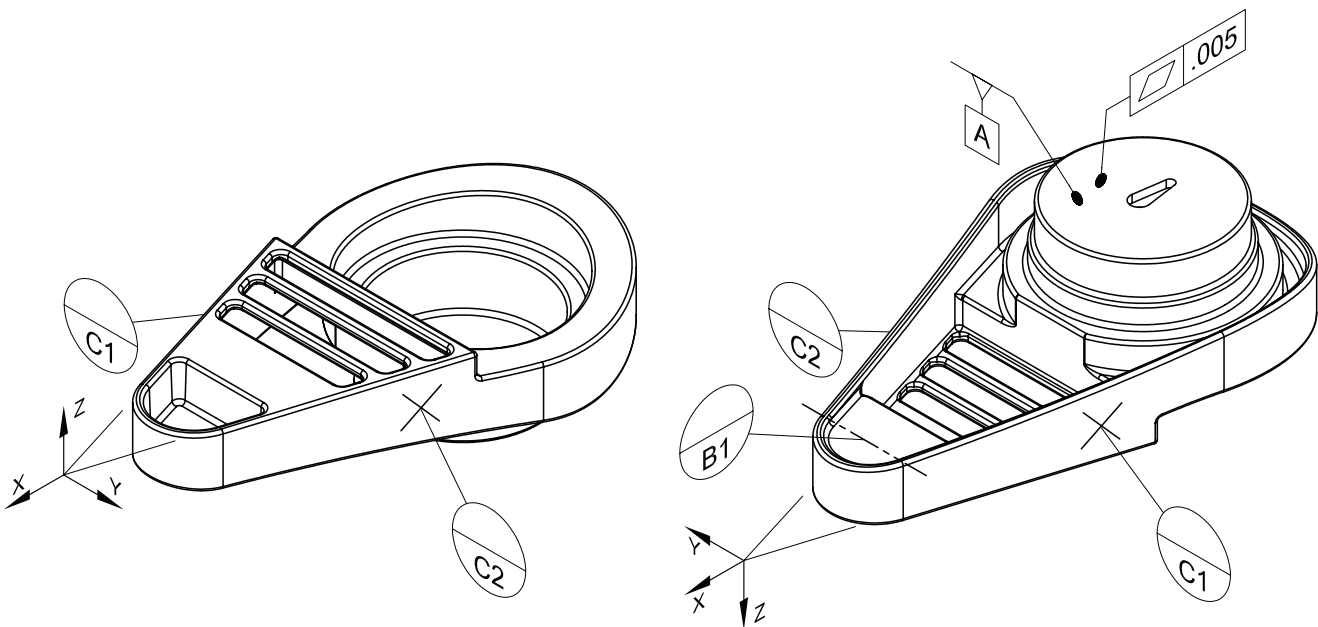

INJECTION MOLDED PART WITH DEFAULT PROFILE TOLERANCE
 FIGURE 26-54

26.33.4.1 Orientation Tolerances Applied to Line Elements of a Surface on Annotated Models and Axonometric Drawing Views. When applying an orientation tolerance to line elements on a surface, it is best practice to model the line element as supplemental geometry and display it on the model or drawing. A notation must be added to the feature control frame stating EACH ELEMENT, further clarifying that the tolerance applies to line elements on the surface – otherwise the tolerance would be misinterpreted as applying to the entire surface all at once rather than each line element on the surface. If the line element is shown, the orientation feature control frame must be attached to a leader that terminates on the line element. If the line element is not modeled or shown, the direction of application is indicated by the orientation of the feature control frame and its associated annotation to the model coordinate system; the feature control frame, leader, and associated annotation must reside on an annotation plane parallel to the desired direction of application. See paragraph 26.14.3.1 for more information. Examples of orientation tolerances applied to line elements may be seen in FIGURES 26-3 and 26-4.

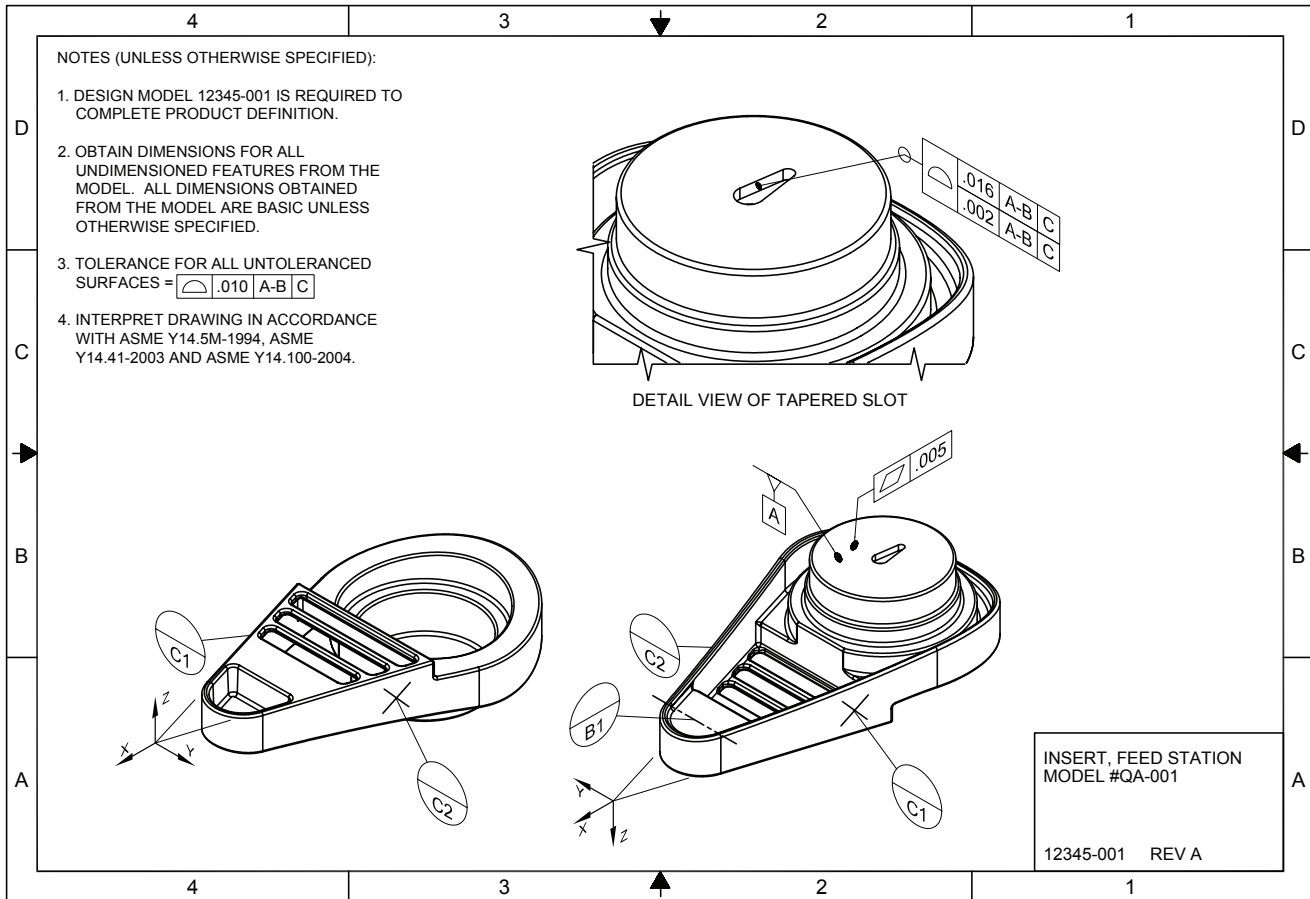

DRAWING WITH DEFAULT PROFILE TOLERANCE: INJECTION MOLDED PART
 FIGURE 26-55

26.33.4.2 Direction Dependent Orientation Tolerances on Annotated Models and Axonometric Drawing Views. Orientation tolerances that control the axis of a feature of size may be specified as a cylindrical tolerance zone or as a width tolerance zone consisting of two parallel planes. If such an orientation tolerance is specified as a width tolerance zone, the direction the tolerance applies (the orientation of the tolerance zone to the datum reference frame) must be specified clearly and unambiguously. In these cases the datum features referenced in the feature control frame alone are insufficient to fully understand how the tolerance zone is to be oriented to the datum reference frame. The direction is indicated by relating the orientation tolerance to a dimension that is in the desired orientation. The orientation of the dimension's extension lines determines the direction or orientation of the tolerance zone. The orientation feature control frame must be attached to a size dimension as shown in FIGURE 26-57c or attached to a dimension line as shown in FIGURE 26-58e. See FIGURES 26-56 – 26-58 for examples of incorrect and correct methods of specifying direction dependent orientation tolerances.

26.33.5 Runout Tolerances on Annotated Models and Axonometric Drawing Views. Total runout and circular runout feature control frames and associated annotation should reside on an annotation plane that is coincident with, parallel to, or perpendicular to the datum axis, or coincident with the datum center point defined by the datum features referenced in the feature control frame. Runout tolerance feature control frames should always be attached to a leader directed to a surface, as runout tolerances control surfaces or surface elements. Examples of runout tolerances applied to annotated models and axonometric drawing views are shown in FIGURES 26-52, and 26-59 – 26-64. Examples of circular runout and total runout specifications are included. Examples of runout tolerances specified between points are also shown in several of the figures. FIGURE 26-61 includes a query and results of total runout applied between points to control a seal groove. This is in an interesting application, and is perhaps one of the most effective ways to tolerance such geometry.

FIGURE 26-62 includes a query and results of total runout applied between points to control a cylindrical surface and an adjacent conical surface. FIGURE 26-64 depicts a rotating part that mates against a surface and fits over a keyed shaft, thus the runout tolerance references datum reference frame A, B, C, which constrains all six degrees of freedom. The datum reference frames in the other examples only eliminate four or five degrees of freedom, which is adequate for those applications. Notice the combined use of profile of a surface and total runout in FIGURES 26-59 – 26-63. The profile of a surface tolerances in these examples require basic dimensions to define the true profile from which the profile tolerance zone is offset. As these figures are examples of annotated models, the basic dimensions exist within the model, and a note should be included that explains that the required basic dimensions must be obtained by querying the model. An example of such a note can be seen in FIGURES 26-54 and 26-55.

Remember, runout tolerancing may be used on any surface of revolution that is coaxial with or perpendicular to a datum axis, or coaxial or coincident with a datum center point, even if the part is not a rotating part.

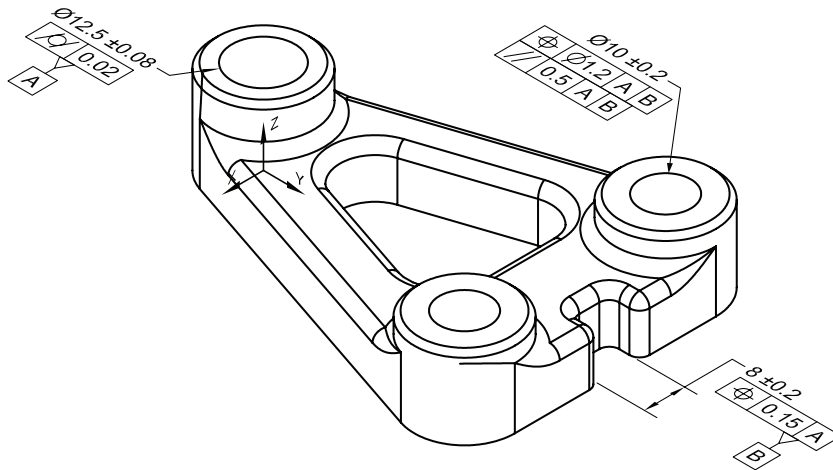

a. Width Parallelism Tolerance Zone Specified Ambiguously: Specification

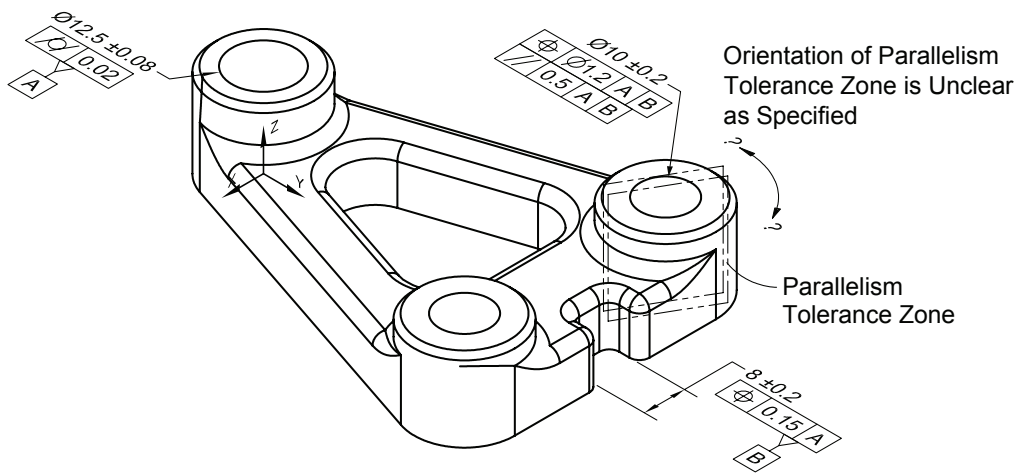

b. Width Parallelism Tolerance Zone Specified Ambiguously: Meaning

SPECIFYING DIRECTION DEPENDENT ORIENTATION TOLERANCES
 FIGURE 26-56

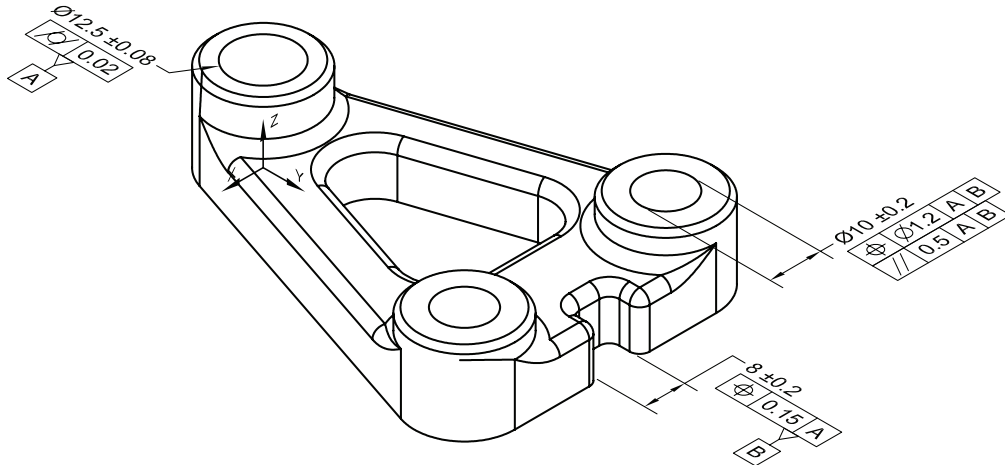

c. Width Parallelism Tolerance Zone Specified with Size Dimension: Specification

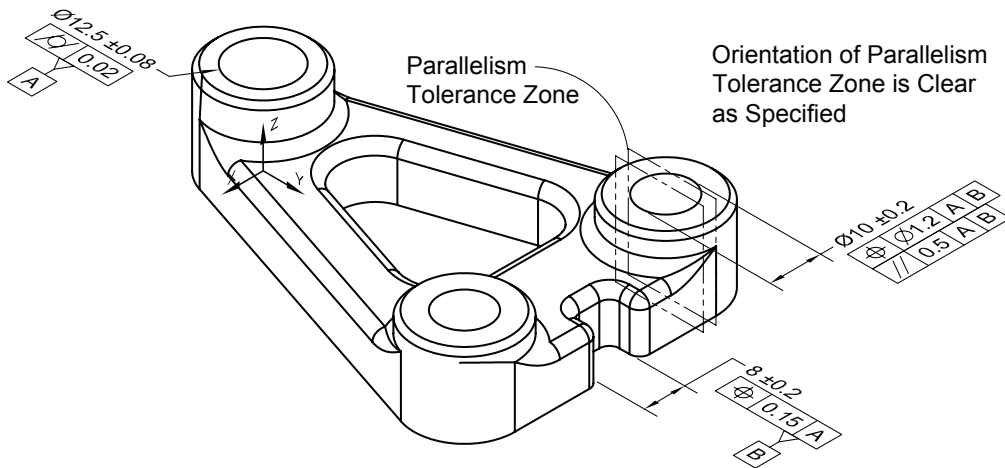

d. Width Parallelism Tolerance Zone Specified with Size Dimension: Meaning

SPECIFYING DIRECTION DEPENDENT ORIENTATION TOLERANCES
FIGURE 26-57

26.33.6 Positional Tolerances on Annotated Models and Axonometric Drawing Views. Positional tolerance feature control frames and associated annotation must reside on an annotation plane that is coincident with, parallel to, or perpendicular to the primary datum feature referenced in the feature control frame. Positional tolerance feature control frames controlling the axis, center point, or center plane of a feature of size are usually attached to or specified with the size dimension for a feature of size or attached to a dimension line, but they may also be attached to a leader directed to the surface if desired. Positional tolerances may be specified on a BOUNDARY basis, specified with a projected tolerance zone, may be applied to single features of size or to patterns of features of size, and may be specified on an INDIVIDUAL basis related to a repetitive datum reference frame. The tolerated feature(s), the positional tolerance feature control frame, any associated annotation, any applicable size dimensions and tolerances, and the model coordinate system for the referenced datum reference frame should be an associated group. This section includes many examples of positional tolerances. Examples of positional tolerances applied to annotated models and axonometric drawing views are

shown in FIGURES 26-1, 26-3 – 26-5, 26-9, 26-14, 26-15, 26-19 – 26-26, 26-39 – 26-42, 26-43, 26-45, 26-52, 26-53, 26-56 – 26-58, 26-65 – 26-72, 26-74, 26-76, 26-77, 26-79 and 26-81.

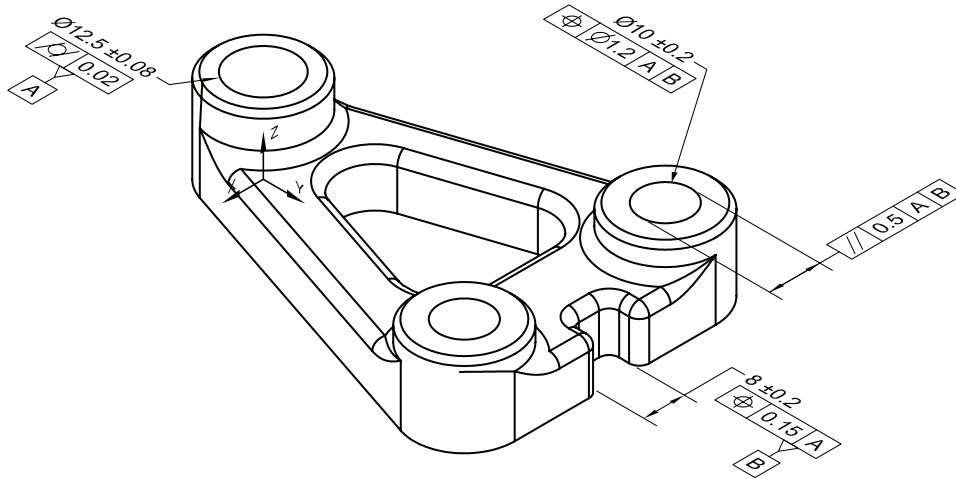

e. Width Parallelism Tolerance Zone Attached to Dimension Line: Specification

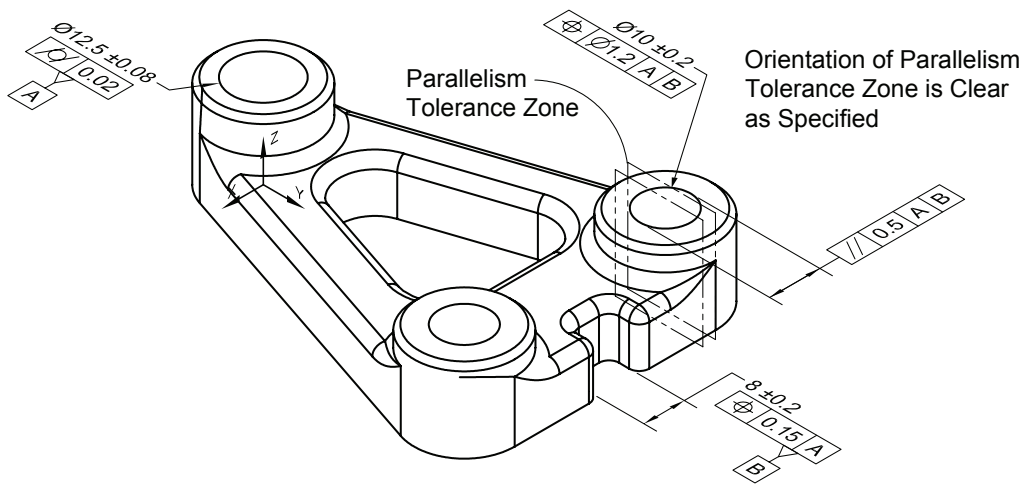

f. Width Parallelism Tolerance Zone Attached to Dimension Line: Meaning

SPECIFYING DIRECTION DEPENDENT ORIENTATION TOLERANCES
 FIGURE 26-58

26.33.6.1 Direction Dependent Positional Tolerances on Annotated Models and Axonometric Drawing Views. Positional tolerances may be specified as direction dependent tolerances. A common application is where a cylindrical feature of size such as a hole is to be located with different tolerances in two perpendicular directions. Width positional tolerance zones are specified in both perpendicular directions, each representing the amount the hole may tilt or shift in that particular direction. In order to ensure the direction the positional tolerance applies is clearly understood, the direction dependent feature control frame must be attached to and associated with the size dimension as shown in FIGURE 26-68 or attached to a dimension line as shown in FIGURE 26-69. Note that the direction of the extension lines determines the direction of the positional tolerance zone – the width positional tolerance zone is parallel to the extension lines.

See FIGURES 26-67 – 26-70 for examples of incorrect and correct applications of this method. FIGURE 26-70 shows bi-directional positional tolerances applied to holes.

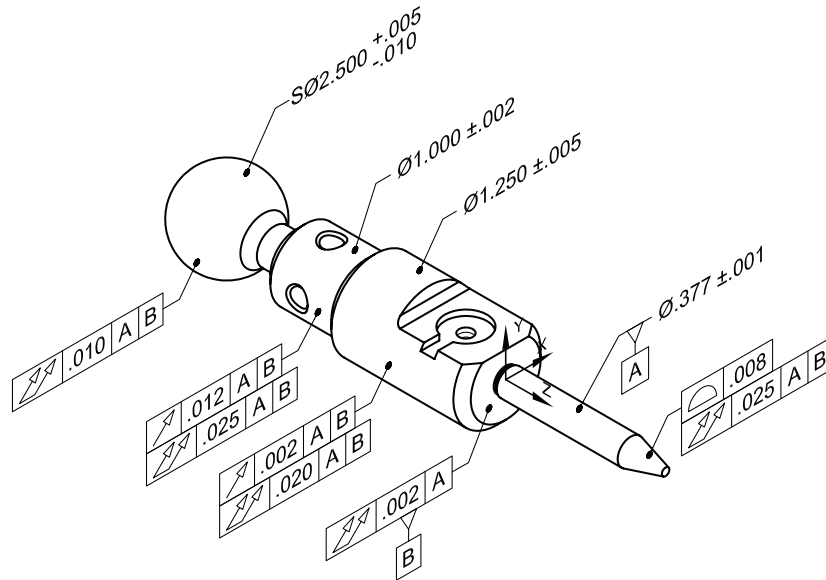

RUNOUT TOLERANCES APPLIED TO A MODEL
FIGURE 26-59

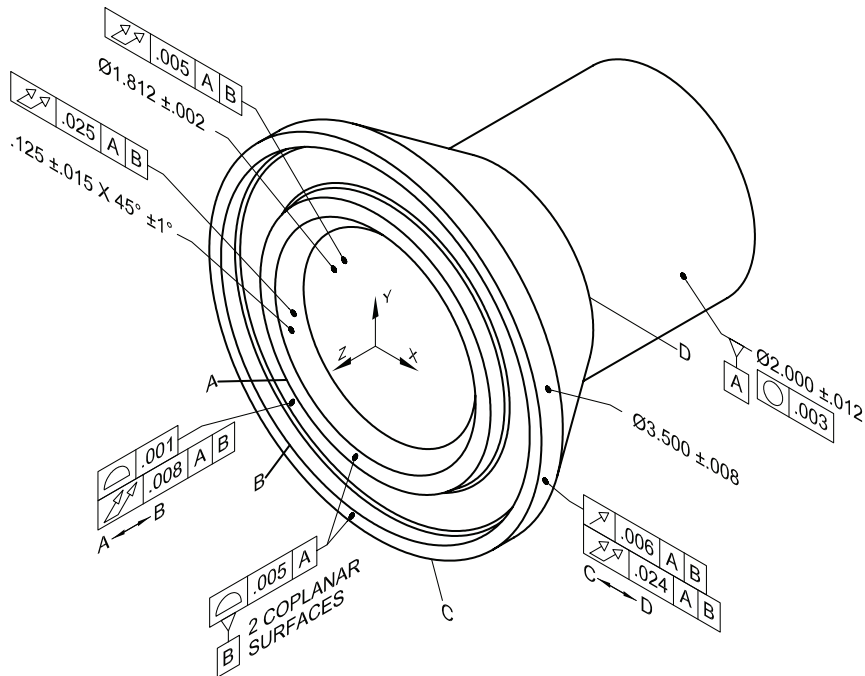

a. Runout Tolerances and Runout Tolerances Between Points

RUNOUT TOLERANCES AND RUNOUT BETWEEN POINTS
FIGURE 26-60

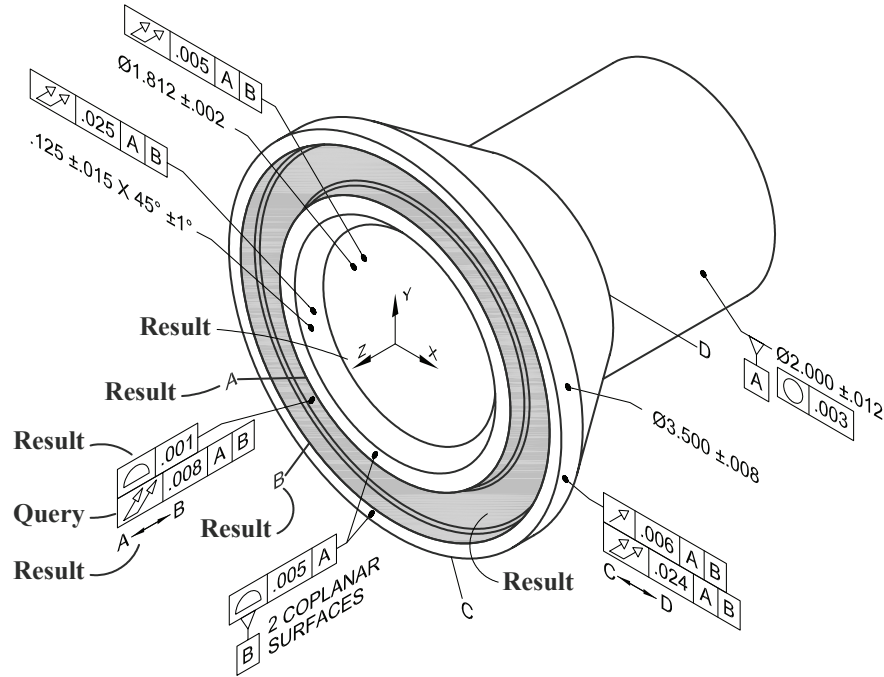

b. Query and Results for Runout Tolerance Between Points A & B

RUNOUT TOLERANCES AND RUNOUT BETWEEN POINTS – QUERY AND RESULTS
FIGURE 26-61

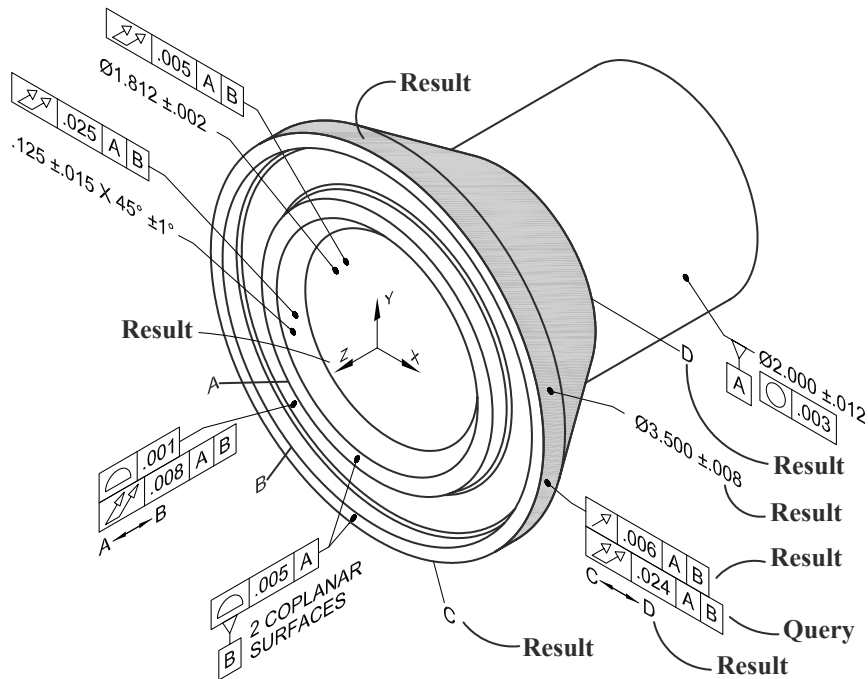

c. Query and Results for Runout Tolerance Between Points C & D

RUNOUT TOLERANCES AND RUNOUT BETWEEN POINTS – QUERY AND RESULTS
FIGURE 26-62

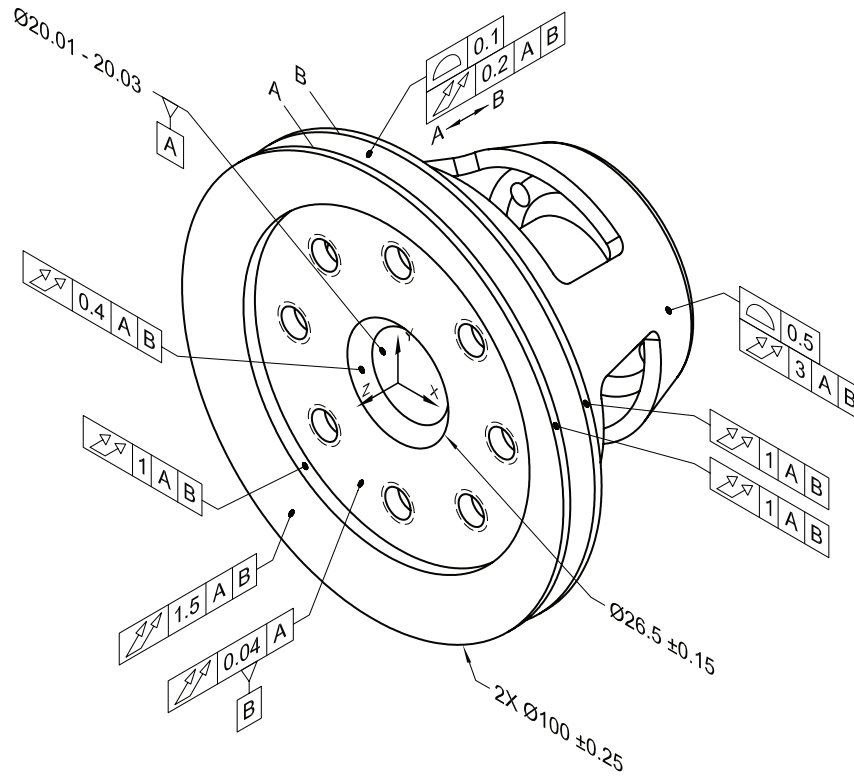

RUNOUT TOLERANCES AND RUNOUT BETWEEN POINTS
FIGURE 26-63

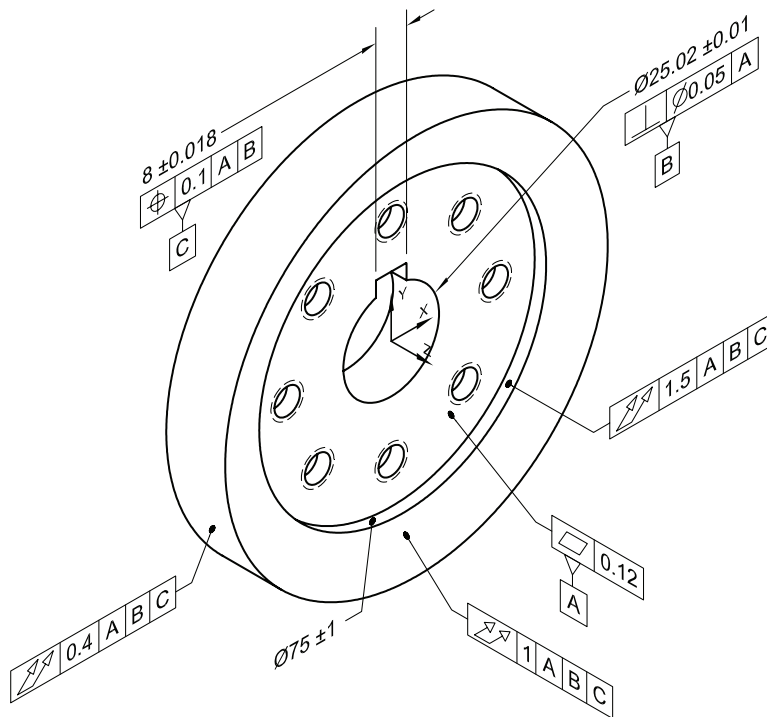

RUNOUT TOLERANCES TO DATUM FEATURES A, B, C
FIGURE 26-64

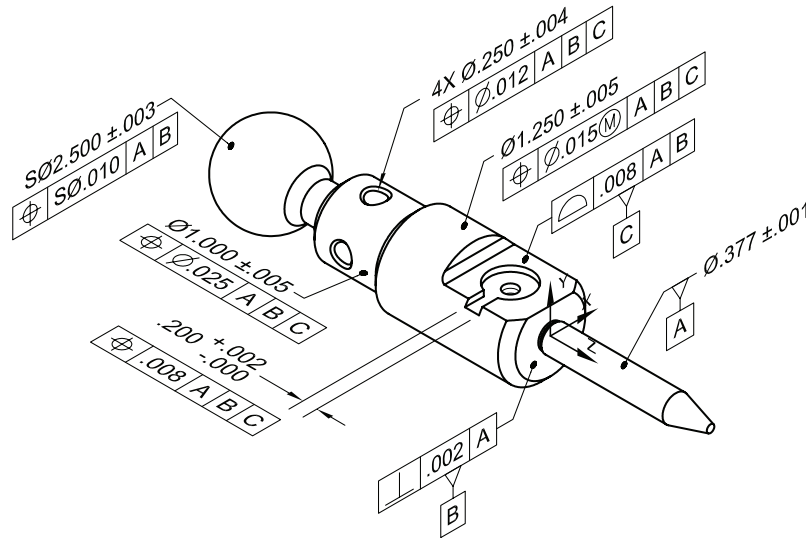

SPHERICAL, CYLINDRICAL, AND WIDTH POSTIONAL TOLERANCE SPECIFICATIONS
FIGURE 26-65

26.33.6.2 Projected Positional Tolerances on Annotated Models and Axonometric Drawing Views.

Positional tolerances may be specified with a projected tolerance zone. This is usually necessary for threaded holes and holes into which a pin or stud will be pressed or welded, or any application where the orientation of a feature will determine a critical distance or deviation when projected some distance from the feature. In general, a projected tolerance zone should be specified if a fixed fastener joint includes threaded holes, as the fixed fastener formula is not valid without projected tolerance zones specified for the threaded holes. There are alternatives, such as formula B5 in Appendix B of ASME Y14.5M-1994 and as described in Chapter 18 of “Mechanical Tolerance Stackup and Analysis”*. Although these alternatives exist, projected tolerance zones are usually a good idea from a functional point-of-view. FIGURES 26-1, 26-9, 26-14, 26-15, 26-41, and 26-72 include projected tolerance zones. On annotated models the positional tolerance feature control frame with the projected tolerance zone specification should be attached to a size dimension directed to surface with a leader as shown in FIGURE 26-72a. The projected tolerance zone originates and projects from the surface where the leader terminates. ASME Y14.41 does not recommend using the chain line method shown in ASME Y14.5, which is used on orthographic drawing views. However, supplemental geometry may be used to clarify the origin and direction of projection. FIGURE 26-72b shows a phantom cylinder as supplemental geometry that represents the minimum height of the projected tolerance zone. This method is actually quite clear and a very useful way to show the projected tolerance zone. If supplemental geometry is used to depict the projected tolerance zone, the positional tolerance feature control frame, the projected tolerance zone geometry, and all other related annotation must be an associated group.

26.33.6.3 Positional Tolerances Related to Repetitive Datum Reference Frames (Specified on an Individual Basis) on Annotated Models and Axonometric Drawing Views. Positional tolerances may be related to a repetitive datum reference frame, which requires the notation INDIVIDUALLY (or abbreviated INDV). This is essentially a way to define multiple similar datum reference frames related to a repeating pattern of features, such as coaxial counterbores and holes. Each repetitive datum reference frame and the features related to it on an annotated model must be an associated group. FIGURE 26-41 shows such an example. Like all datum reference frames, each individual datum reference frame must be associated to a unique model coordinate system. For example, if the repetitive datum reference frame specification created five distinct datum reference frames, each would have its own model coordinate system.

26.33.6.4 Positional Tolerances Grouped Using Simultaneous Requirements (SIM REQTS) on Annotated Models and Axonometric Drawing Views. Geometric tolerance feature control frames related to the same datum reference frame are considered as a simultaneous requirement by default per the rules in ASME Y14.5.

* Mechanical Tolerance Stackup and Analysis, Fischer, Bryan, New York, NY, CRC Press / Marcel Dekker, 2004

This means that all geometric tolerance zones related to the same datum reference frame may be considered as a pattern, and to put it into inspection terms, must be inspected in the same setup. However, this relationship may not be obvious to the person reading the drawing or annotated model, especially where the referenced datum features do not eliminate sufficient degrees of freedom to completely immobilize the geometric tolerance zones. FIGURE 26-41 shows two nominally coaxial holes with the notation “SIM REQ T 1” beneath their positional tolerance feature control frames, and both are positionally tolerated to datum feature A. Neither hole is functionally more important than the other, and both are only perpendicular to datum A. However, they are to be used as multiple datum feature B-C, thus their coaxiality must be controlled as well as their orientation to datum A – this is the reason that positional tolerances are specified instead of perpendicularity tolerances. Technically, the notation “SIM REQ T 1” is not required, as simultaneous requirements applies by default, but is included here to clarify the requirement to the person reading the model.

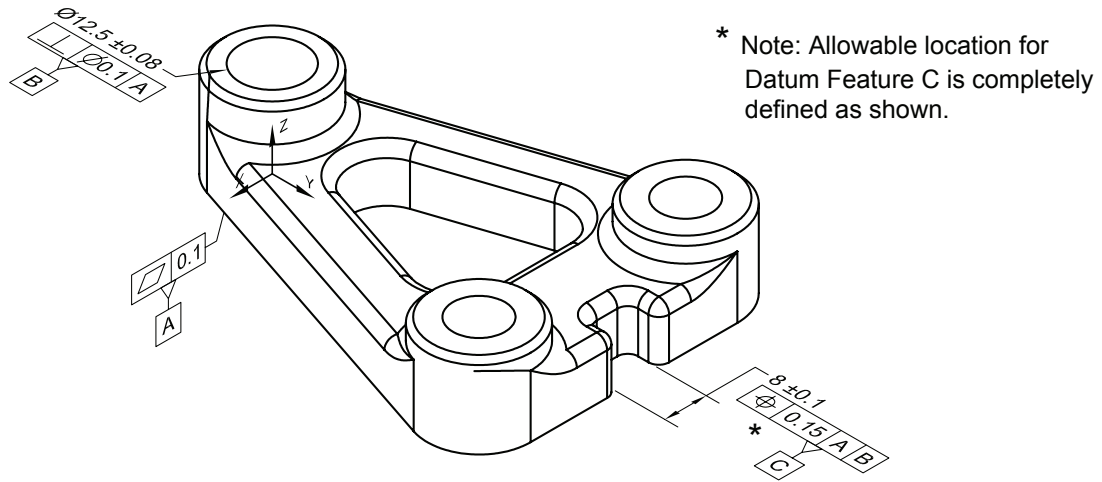

a. Width Positional Tolerance Zone Applied to a Width Feature of Size: Specification

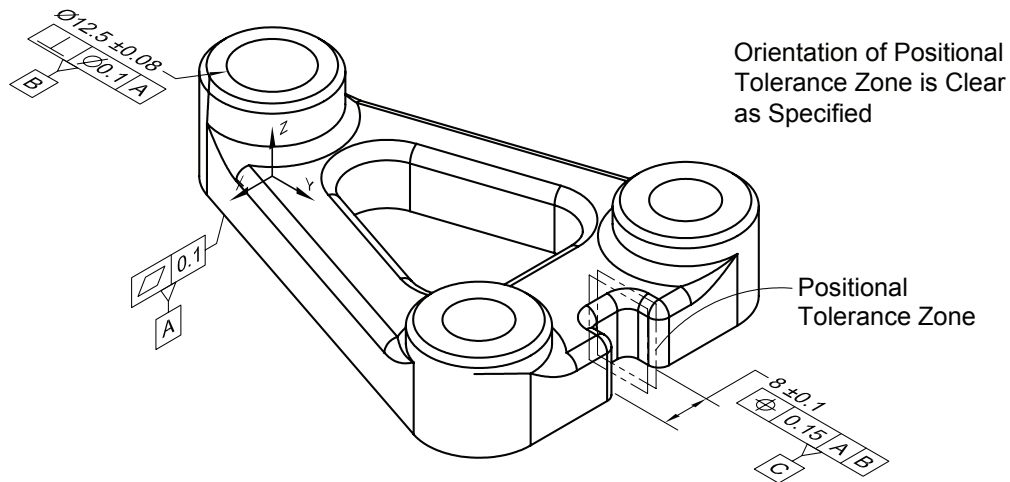

b. Width Positional Tolerance Zone Applied to a Width Feature of Size: Meaning

POSITIONAL TOLERANCE APPLIED TO A WIDTH FEATURE OF SIZE

FIGURE 26-66

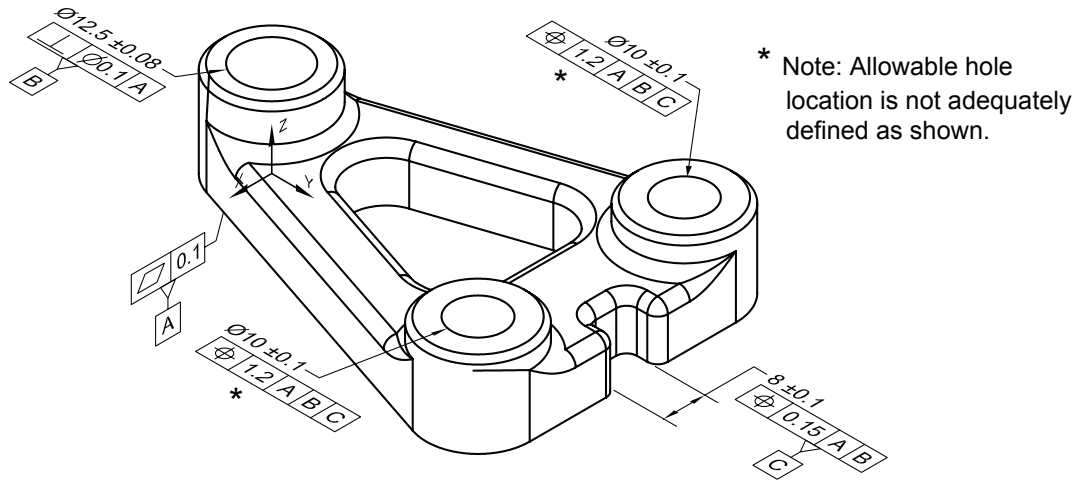

c. Width Positional Tolerance Zones Specified Ambiguously: Specification

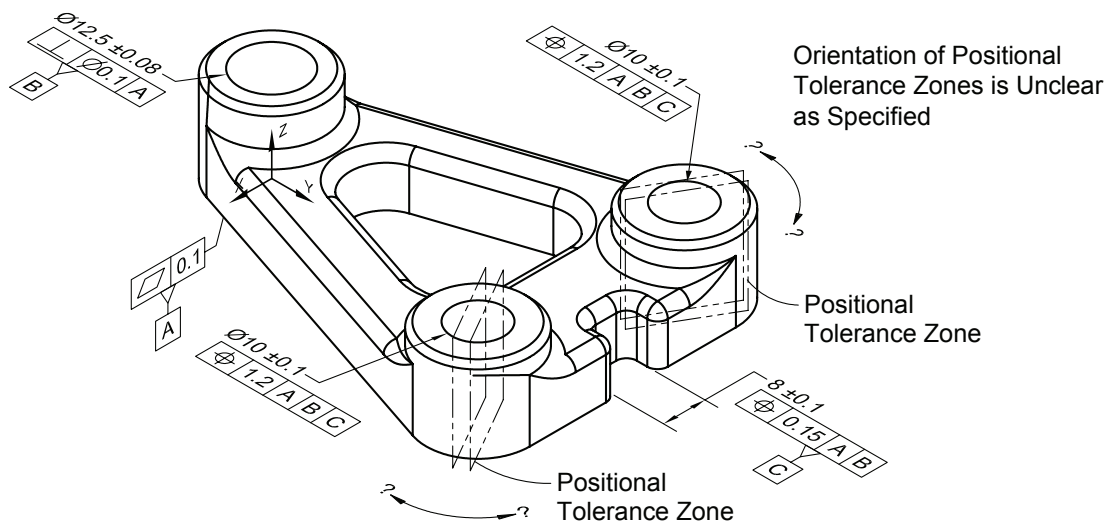

d. Width Positional Tolerance Zones Specified Ambiguously: Meaning

SPECIFYING DIRECTION DEPENDENT POSITIONAL TOLERANCES
FIGURE 26-67

26.33.7 Concentricity Tolerances on Annotated Models and Axonometric Drawing Views. Concentricity tolerance feature control frames and associated annotation should reside on an annotation plane that is coincident with, parallel to, or perpendicular to the datum axis, or coincident with the datum center point defined by the datum features referenced in the feature control frame. The tolerated feature(s), the concentricity tolerance feature control frame, any associated annotation, any applicable size dimensions and tolerances, and the model coordinate system for the referenced datum reference frame should be an associated group. See FIGURE 26-73 for examples of concentricity tolerances applied to an annotated model.

26.33.8 Symmetry Tolerances on Annotated Models and Axonometric Drawing Views. Symmetry tolerance feature control frames and associated annotation should reside on an annotation plane that is coincident with, parallel to, or perpendicular to the datum axis or datum center plane defined by the datum features referenced in the feature control frame. The tolerated feature(s), the symmetry tolerance feature control frame, any associated annotation, any applicable size dimension and tolerance, and the model coordinate system for the referenced datum reference frame should be an associated group. See FIGURE 26-74 for examples of symmetry tolerances applied to an annotated model.

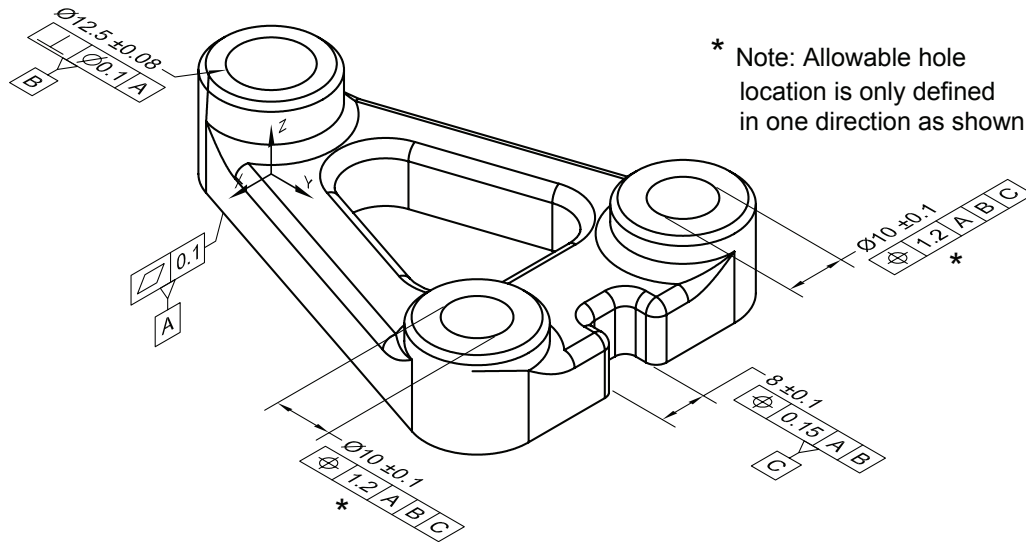

e. Width Positional Tolerance Zones Specified with Size Dimension: Specification

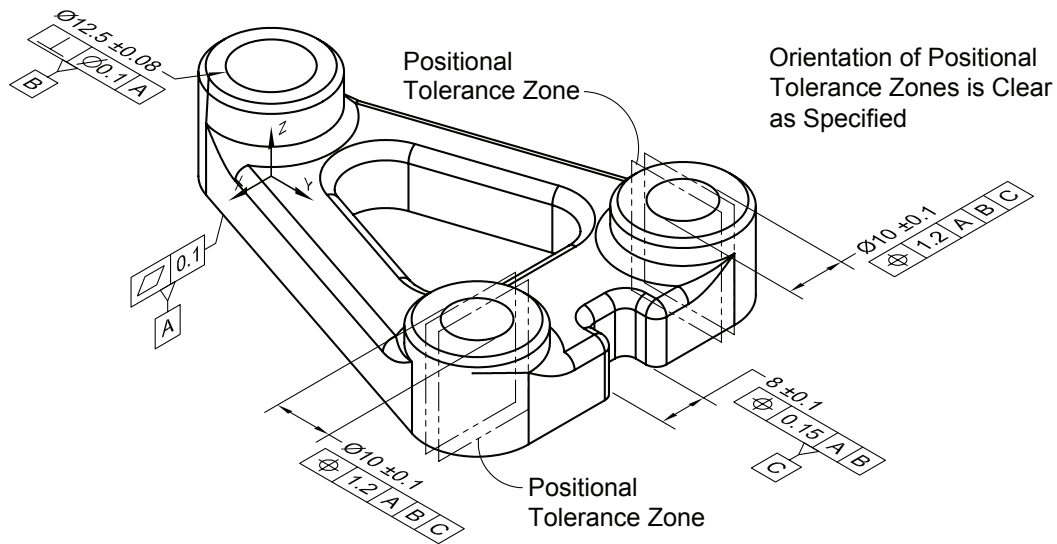

f. Width Positional Tolerance Zones Specified with Size Dimension: Meaning

SPECIFYING DIRECTION DEPENDENT POSITIONAL TOLERANCES

FIGURE 26-68

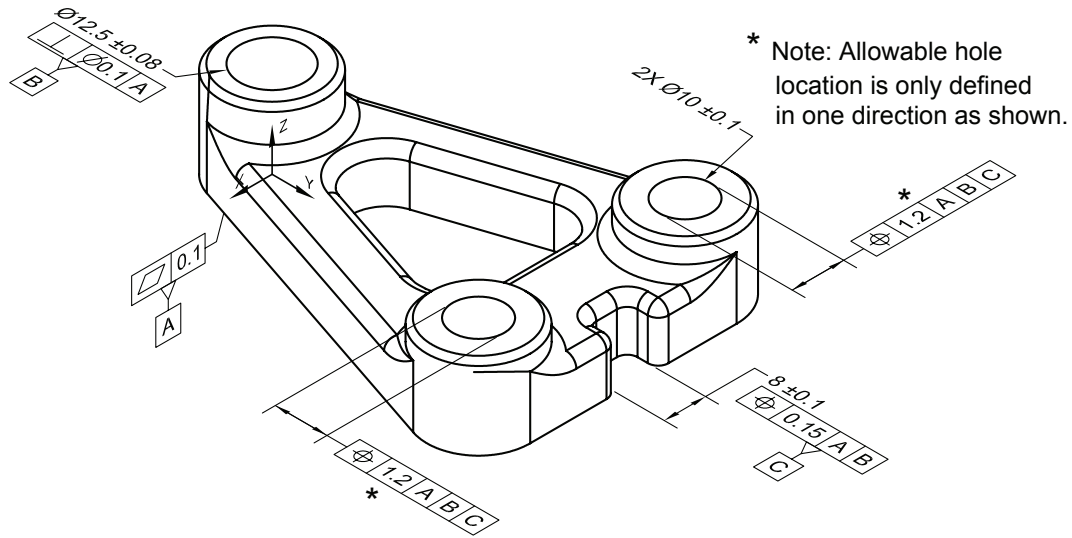

g. Width Positional Tolerance Zones Attached to Dimension Line: Specification

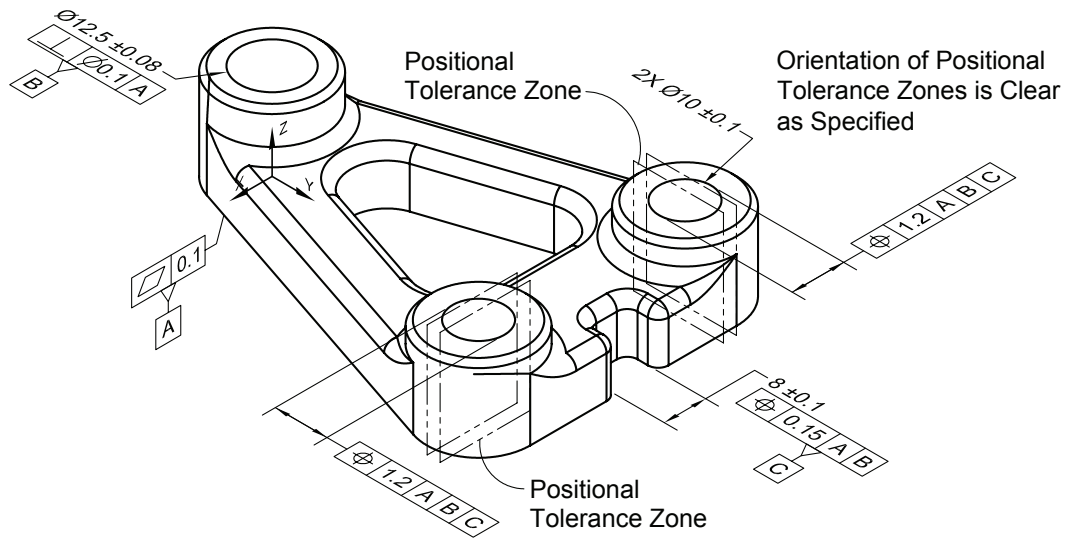

h. Width Positional Tolerance Zones Attached to Dimension Line: Meaning

SPECIFYING DIRECTION DEPENDENT POSITIONAL TOLERANCES
FIGURE 26-69

26.33.9 Profile Tolerances on Annotated Models and Axonometric Drawing Views. Profile of a surface and profile of a line feature control frames and associated annotation must reside on an annotation plane that meets the requirements in the sub-paragraphs that follow. Profile tolerance feature control frames should always be attached to a leader directed to a surface, as profile tolerances control surfaces or surface elements. The tolerated feature(s), the profile tolerance feature control frame, any associated annotation, and the model coordinate system for the referenced datum reference frame should be an associated group. This section includes many examples of profile tolerances, as profile tolerances are the most versatile geometric tolerances and may be applied to any surface.

The three-dimensional profile tolerancing methods in this section are practically the only way to adequately and completely define the geometry of the complex and free-formed shapes common in industry today. In fact, industry is the driving force behind these new tools and techniques. Examples of profile tolerances applied to annotated models and axonometric drawing views are shown in FIGURES 26-1, 26-3 – 26-5, 26-9, 26-14, 26-15, 26-19 – 26-29, 26-39, 26-41 – 26-45, 26-48, 26-49, 26-52, 26-53, 26-54, 26-55, 26-59, 26-60, 26-65, 26-63, and 26-77 – 26-82.

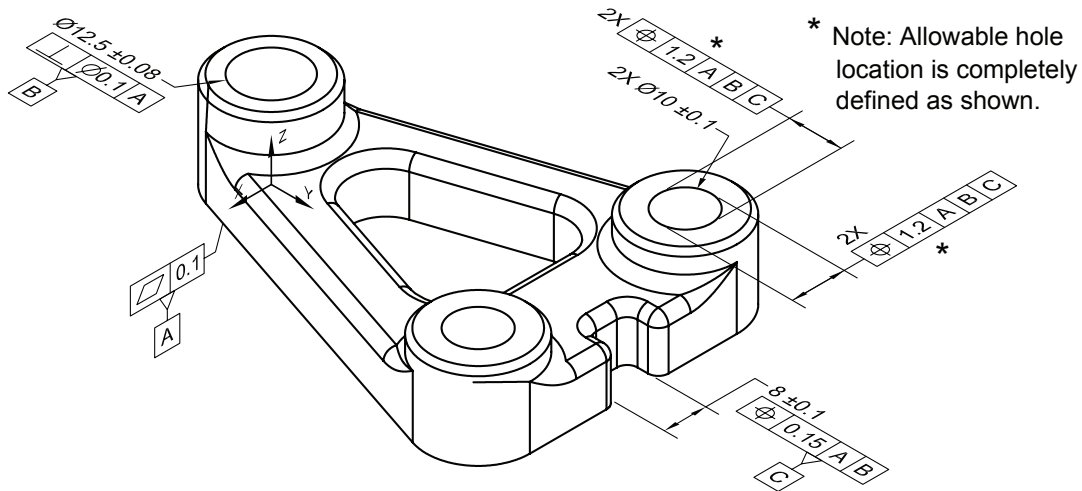

i. Bi-Directional Width Positional Tolerance Zones Attached to Dimension Line: Specification

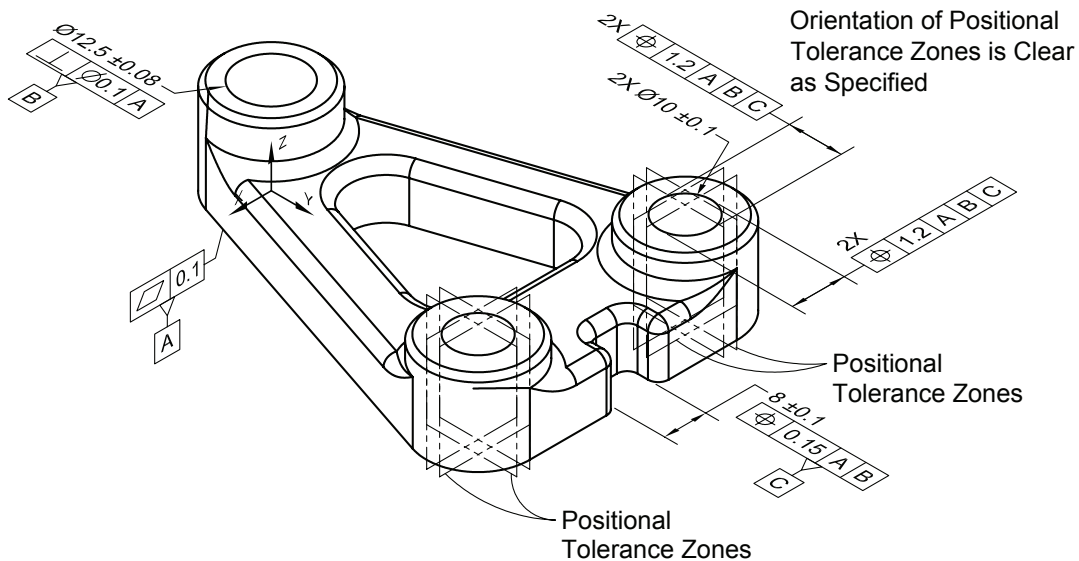

j. Bi-Directional Width Positional Tolerance Zones Attached to Dimension Line: Meaning

SPECIFYING DIRECTION DEPENDENT POSITIONAL TOLERANCES
 FIGURE 26-70

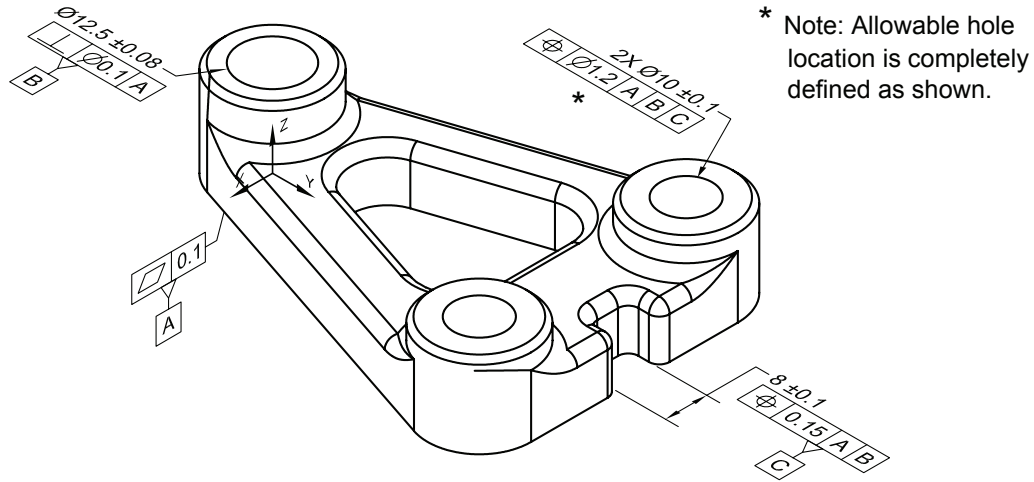

k. Cylindrical Positional Tolerance Zones Attached to Size Dimension: Specification

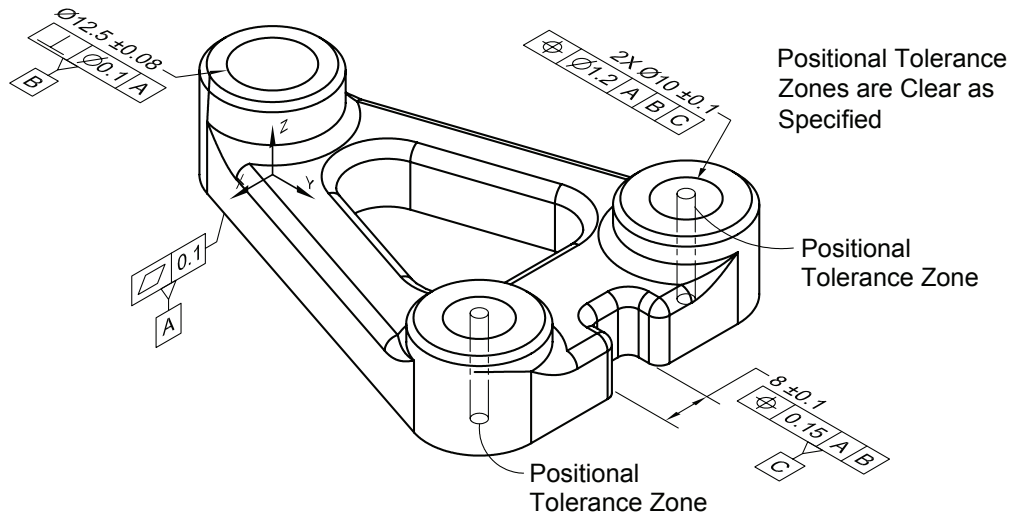

l. Cylindrical Positional Tolerance Zones Attached to Size Dimension: Meaning

SPECIFYING CYLINDRICAL POSITIONAL TOLERANCES

FIGURE 26-71

26.33.9.1 Profile of a Line Tolerances on Annotated Models and Axonometric Drawing Views. Profile of a line tolerances are specified to control line elements on a surface. Note that in the context of GD&T, line elements may be straight lines, curves, or a combination thereof. A profile of a line tolerance controls and creates a tolerance zone for each and every line element on the tolerated surface, and each tolerance zone applies independently. On orthographic drawing views the direction that a profile of a line tolerance applies is determined by the view in which the tolerance is specified – it is a view-specific tolerance. This sort of approach does not work on annotated models, as they may be rotated while viewing, thereby changing the orientation of



the view to the model and the annotation, and losing the significance of the viewing direction. ASME Y14.41 overcomes this limitation by requiring profile of a line tolerances to be specified as follows:

1. **Represented Line Element.** The profile of a line feature control frame is specified with and associated to a represented line element (supplemental geometry) that portrays the direction of application. The profile of a line feature control frame must reside on an annotation plane that contains the represented line element. If the profile of a line tolerance is not related to a datum reference frame, the annotation plane must be parallel or perpendicular to one of the planes in an absolute (global) or user-defined coordinate system; if the profile of a line tolerance is related to a datum reference frame, it is also a good idea for the annotation plane to be parallel or perpendicular to the referenced primary datum or datum feature. See paragraph 26.14.3.1 and FIGURE 26-5 for more information.
2. **Related to a Model Coordinate System Axis.** The profile of a line feature control frame is aligned to the x, y, or z axis of the associated model coordinate system. The profile of a line feature control frame must reside on an annotation as follows: if the profile of a line tolerance is not related to a datum reference frame, the annotation plane must be parallel or perpendicular to one of the planes in an absolute (global) or user-defined coordinate system; if the profile of a line tolerance is related to a datum reference frame, it is also a good idea for the annotation plane to be parallel or perpendicular to the referenced primary datum or datum feature.

26.33.9.2 Profile Tolerances Specified on a Between Basis on Annotated Models and Axonometric

Drawing Views. Profile and other geometric tolerances may be specified on a between basis. This technique may be used to apply a common tolerance zone to a group of contiguous features, or it may be used to limit a tolerance to only a portion of a feature rather than the entire feature. This technique is very powerful and has many applications.

There is a subtle difference between the techniques used on orthographic drawings and the techniques used on annotated models and axonometric drawing views. On orthographic drawing views (ASME Y14.5), this technique is called the “between points basis.” The extents of application for the tolerance are depicted as points, and the tolerance applies to all features between these points. On annotated models and axonometric drawing views (ASME Y14.41), this technique is simply called the “between basis.” The extents of application for the tolerance are depicted as lines or curves on the model, and the tolerance applies to all features between these lines or curves. The between basis method shown in this section is superior in many ways to the between points method for orthographic drawings. The between basis method shown in this section works very well with complex shapes; the between points method for orthographic drawings is fairly limited, and works best with linear extrusions and other relatively simple shapes.

Using the between basis, the lines or curves representing the extents of the tolerance application are labeled using letters “A”, “B”, “C”, “D”, etc. Often these lines or curves are edges of surfaces or intersections of surfaces. This is commonly used where it is desired to apply a common tolerance zone across multiple features. See FIGURES 26-41, 26-60 – 26-63, and 26-77 – 26-82 for examples of this technique. Alternatively, supplemental geometry may be used to represent the extents of application for the tolerance. This technique is commonly used where the tolerance only applies to a portion of a feature rather than the entire feature. In both cases, the between symbol (e.g. A↔B) should be specified with the feature control frame to clarify that the tolerance applies on a between basis. The feature control frame, the between symbol, the supplemental geometry and annotation representing the extents of application, the toleranced feature or features, and the applicable model coordinate system (if any) should be an associated group. FIGURE 26-61 shows a query and results for these techniques applied with profile of a surface and total runout.

26.33.9.3 Profile Tolerances Specified on an All-Around Basis on Annotated Models and Axonometric

Drawing Views. Profile and other geometric tolerances may be specified on an all-around basis. Typically, all-around basis tolerancing is used to apply a common tolerance zone to a closed, linear-extruded group of contiguous features, such as an elongated hole (a slot), a hexagonal shaft, etc. The all-around symbol is applied to the leader attached to the profile tolerance feature control frame. The feature control frame, the all-around symbol, the toleranced feature or features, and the applicable model coordinate system (if any) should be an associated group. When applied to an annotated model, query should be used to ensure it is clearly

understood which features are controlled by the all-around specification. See FIGURES 26-28, 26-39, 26-40, 26-43, 26-45, 26-54 and 26-55 for examples of profile tolerances applied on an all-around basis.

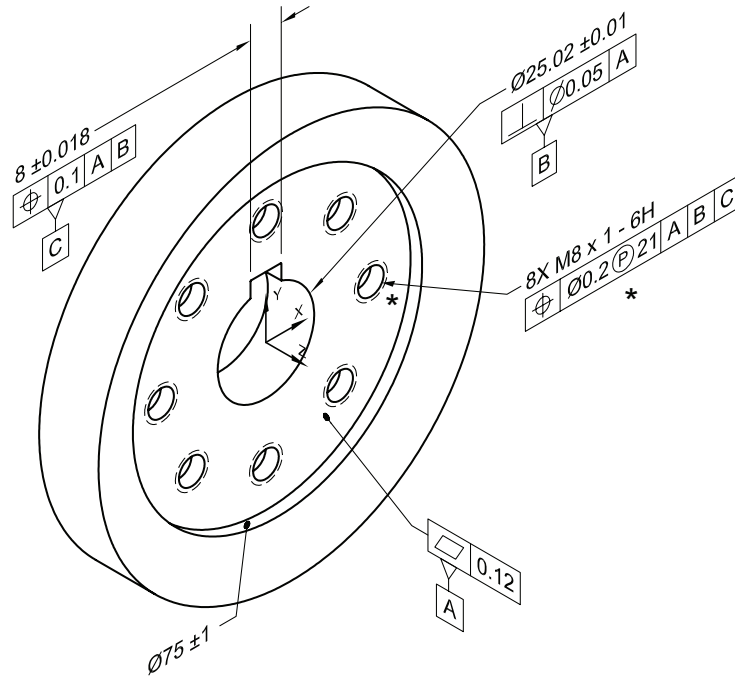

a. Position with Projected Tolerance Zones: Leader Determines Direction and Origin of Projected Tolerance Zones

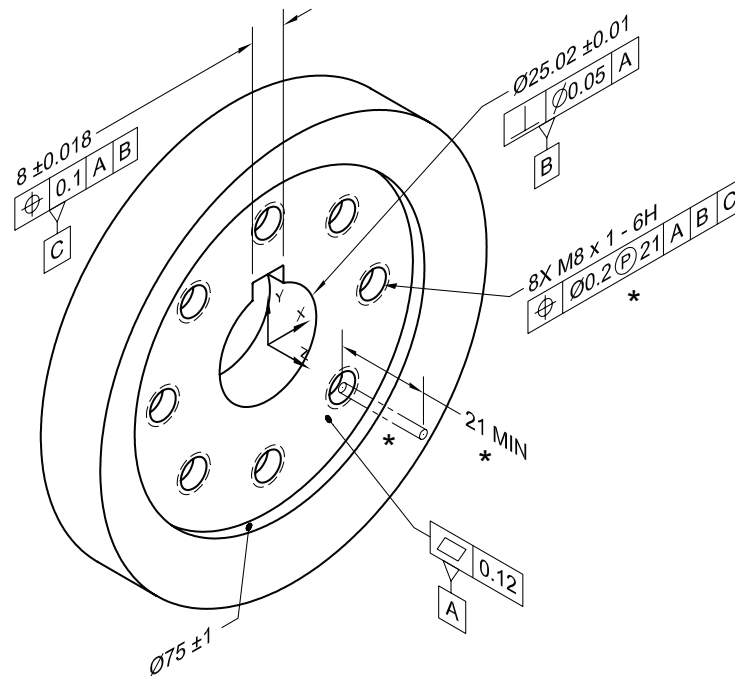

b. Position with Projected Tolerance Zones: Supplemental Geometry Determines Direction and Origin of Projected Tolerance Zones

SPECIFYING POSITIONAL TOLERANCES WITH PROJECTED TOLERANCE ZONES
FIGURE 26-72

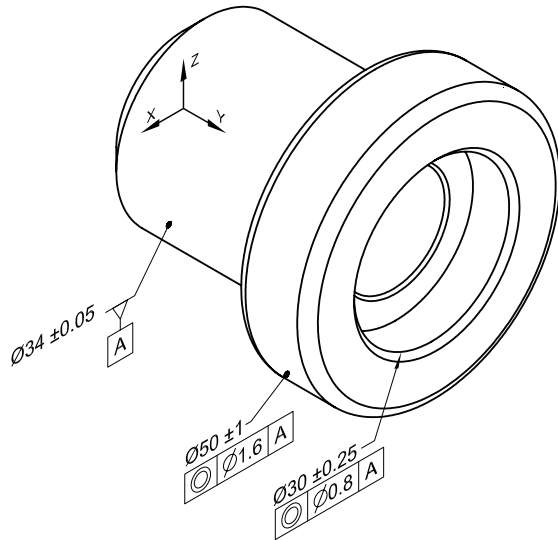

a. Concentricity Attached to Size Dimension and Tolerance

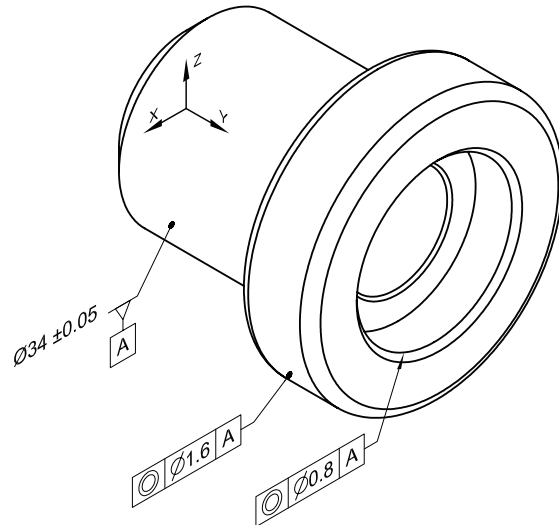

b. Concentricity Directed to Surface by a Leader

SPECIFYING CONCENTRICITY TOLERANCES
 FIGURE 26-73

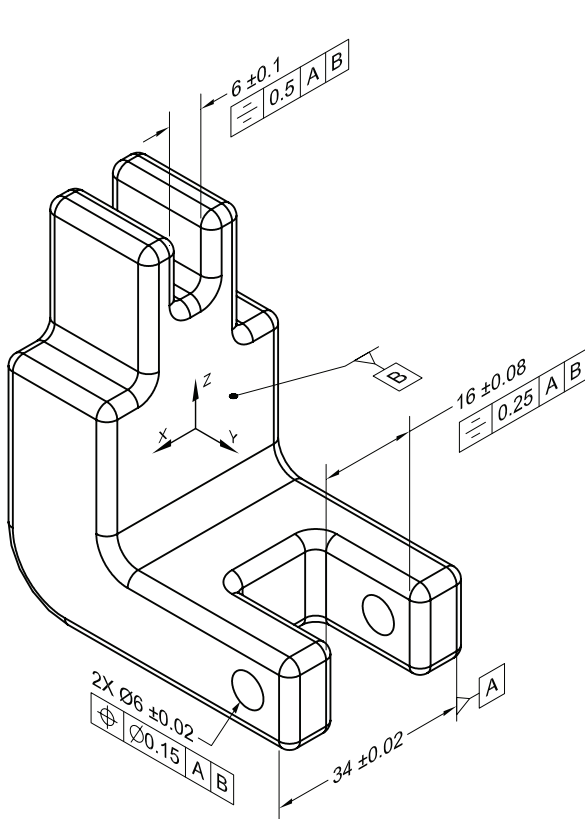

a. Symmetry Attached to Size Dimension and Tolerance

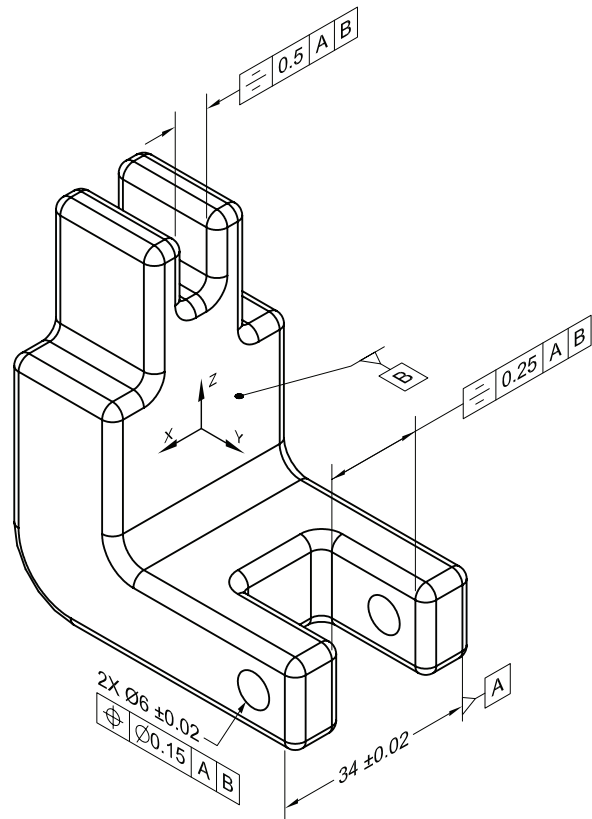

b. Symmetry Attached to Dimension Line

SPECIFYING SYMMETRY TOLERANCES
 FIGURE 26-74



26.33.9.4 Applying Profile Tolerances to Coplanar Surfaces and Multiple Surfaces on Annotated Models and Axonometric Drawing Views. Profile tolerances may be applied to control the relationship between multiple surfaces on a model. Such a specification defines the allowable form (and possibly size) error allowed for each toleranced surface, the allowable orientation and location error between the toleranced surfaces, and if a datum reference frame is referenced, the allowable orientation and location error between the toleranced surfaces and the datum reference frame. A common application is where profile of a surface is used to control the coplanarity between nominally coplanar surfaces. Typically a notation is placed beneath the feature control frame indicating the number of features to be controlled, such as “2 SURFACES”, “4 SURFACES”, etc. See the profile tolerance applied to datum feature A in FIGURE 26-1 for an example of profile of a surface used to control coplanarity. If one or more datum features are referenced in the profile feature control frame, the feature control frame and associated annotation must reside on an annotation plane that is coincident with, parallel to, or perpendicular to the applicable primary datum. The feature control frame, any associated annotation, the toleranced feature or features, and the applicable model coordinate system (if any) should be an associated group. See FIGURES 26-1, 26-9, 26-10, 26-12, 26-13, 26-14, 26-15, 26-39, 26-42, 26-52, 26-60 – 26-62 for examples.

26.33.9.5 Equal-Bilateral, Unequal-Bilateral, and Unilateral Profile Tolerances Specified on Annotated Models and Axonometric Drawing Views. By default, profile tolerances apply normal (perpendicular) to the true profile (or nominal surface). The boundaries of a profile tolerance zone are offset from the true profile. The specified profile tolerance value represents the total width of the tolerance zone, so a profile tolerance of .010” is .010” wide, and a profile tolerance of 3.5mm is 3.5mm wide. Profile tolerances may be specified to apply on an equal-bilateral, unequal-bilateral, or unilateral basis. The difference between these methods lies in how the profile tolerance zone boundaries are offset from the true profile.

ASME Y14.41 includes a new modifier called the *Unequally Disposed Modifier* (or circle-U symbol) to be used with profile tolerances on annotated models and axonometric drawing views. The unequally disposed modifier may be used with any profile tolerance, but is mandatory if unequal-bilateral and unilateral profile tolerances are applied to annotated models or axonometric drawing views. The use of the unequally disposed modifier with equal-bilateral profile tolerances is optional on annotated models or axonometric drawing views. The unequally-disposed modifier is specified immediately after the profile tolerance value, and the amount that the outward profile tolerance zone boundary is offset from the true profile immediately follows the unequally-disposed modifier. FIGURE 26-75 includes a profile tolerance with the unequally-disposed modifier, a diagram showing where it is placed in the feature control frame, the meaning of the numerical tolerance values that precede and follow the modifier, and examples of equal-bilateral, unequal-bilateral, and unilateral tolerance specifications. FIGURES 26-41 and 26-79 – 26-82 show examples of profile tolerances specified with the unequally disposed modifier.

Equal-Bilateral Profile Tolerance. Equal-bilateral profile tolerance zone boundaries are offset the same amount in both directions from the true profile. The equal-bilateral profile tolerance zone boundaries are offset half the tolerance value from the true profile. For example, an equal-bilateral profile tolerance of .010” creates one boundary that is offset .005” out from the true profile, and another boundary that is offset .005” in from the true profile; an equal-bilateral profile tolerance of 3.5mm creates one boundary that is offset 1.75mm out from the true profile, and another boundary that is offset 1.75mm in from the true profile. This method can be visualized in a simplified manner as *plus and minus half the profile tolerance value from nominal*. Equal-bilateral profile tolerance zones may be specified on annotated models and axonometric drawing views with the unequally-disposed modifier in the feature control frame, or they may be specified using the technique that does not require the modifier. FIGURES 26-77 and 26-78 show examples of equal-bilateral profile tolerances specified without the unequally disposed modifier, and FIGURES 26-79, and 26-80 show the same profile tolerances specified with the unequally disposed modifier. The resulting tolerance zone boundaries are shown and explained in the figures as well.



Unequal-Bilateral Profile Tolerance. Unequal-bilateral profile tolerance zone boundaries are offset different amounts in both directions from the true profile. The profile tolerance value represents the total width of the tolerance zone, and the amount the boundaries are offset is determined by the value following the unequally disposed modifier in the feature control frame. This method can be visualized in a simplified manner as *plus some amount and minus a different amount from nominal, where the sum of the values equals the profile tolerance value*. The outward unequal-bilateral profile tolerance zone boundary is offset the amount specified after the unequally-disposed modifier, and the inward profile tolerance zone boundary is offset the amount that remains when the outward offset distance is subtracted from the total profile tolerance value. See FIGURE 26-75 for more explanation. FIGURES 26-41 and 26-81 and 26-82 show examples of unequal-bilateral profile tolerances specified with the unequally disposed modifier.

Unilateral Profile Tolerance. A unilateral profile tolerance zone has one boundary that is offset in or out from the true profile, and the true profile is used as the other profile tolerance zone boundary. The profile tolerance value represents the total width of the tolerance zone, and the amount the unilateral boundary is offset is determined by the value following the unequally disposed modifier in the feature control frame. Two choices are possible: the entire profile tolerance value is repeated after the unequally-disposed modifier, which defines a unilateral outward tolerance zone; or a zero value follows unequally-disposed modifier, which defines a unilateral inward tolerance zone. This method can be visualized in a simplified manner as *plus the entire amount, minus zero from nominal, or minus the entire amount, plus zero from nominal, depending on the specification*. See FIGURE 26-75 for more explanation. FIGURES 26-41 and 26-81 and 26-82 show examples of unilateral profile tolerances specified with the unequally disposed modifier.

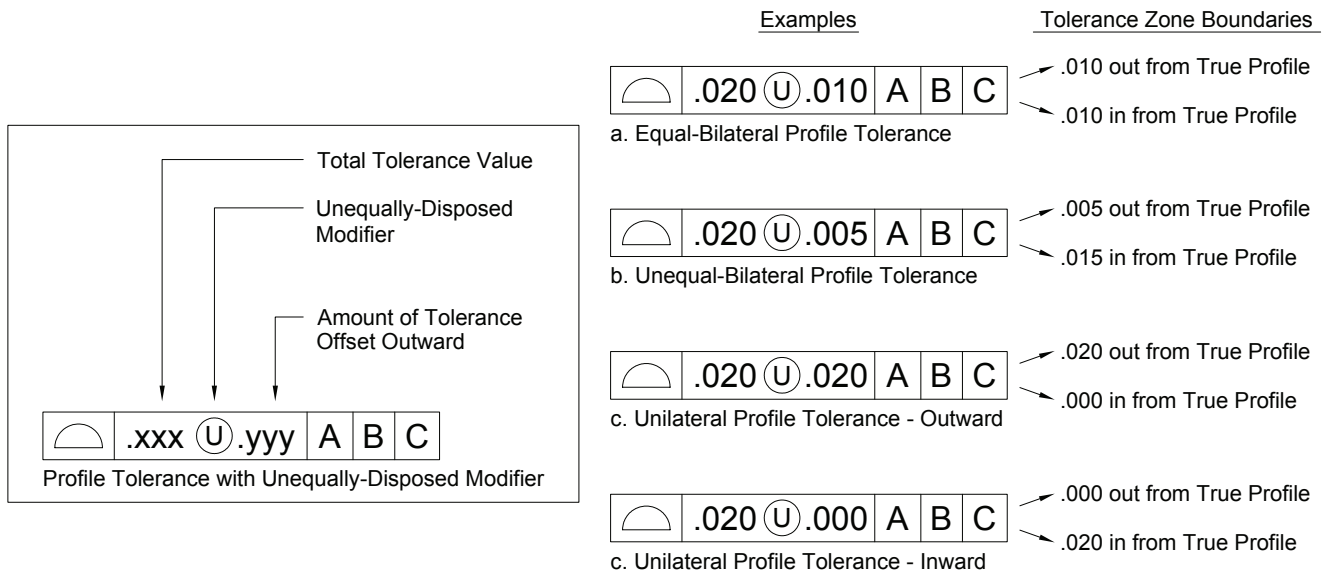

UNEQUALLY-DISPOSED MODIFIER
FIGURE 26-75

26.33.9.6 Applying Profile Tolerances to Conical Surfaces on Annotated Models and Axonometric Drawing Views. Profile tolerances may be applied to control conical surfaces. The profile tolerance feature control frame and associated annotation must reside on an annotation plane that is coincident with or perpendicular to the axis of the conical feature. See FIGURES 26-19 – 26-26 for examples.



ALL INTERNAL BEND
RADII R6 ±1

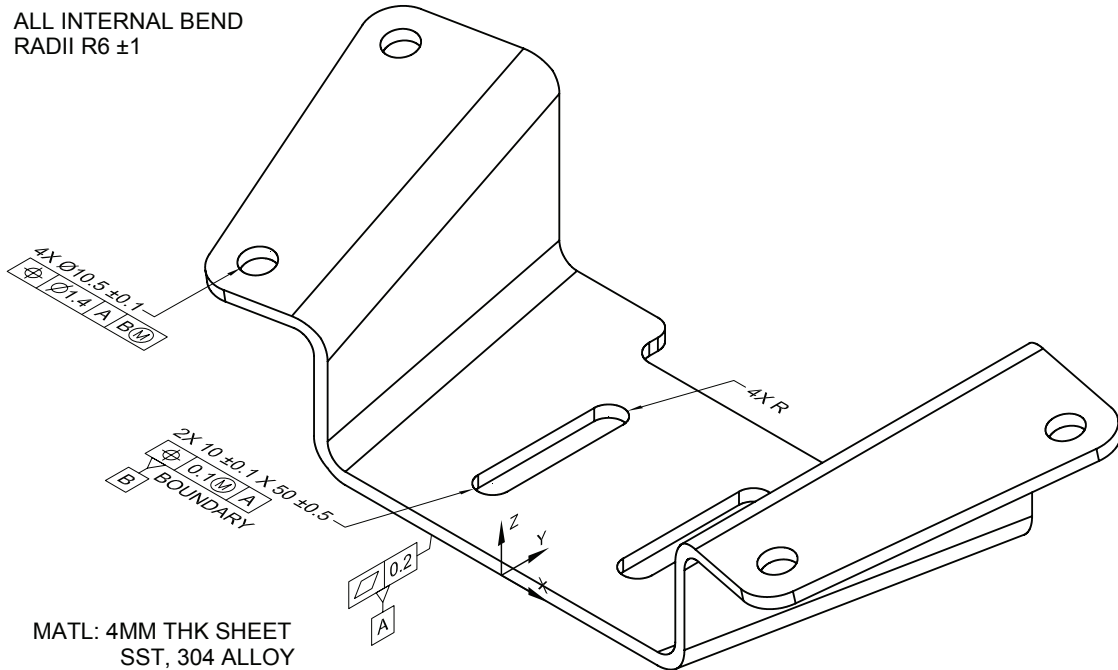

a. Datum Features and Position: Bounded Features as Datum Feature B

ALL INTERNAL BEND
RADII R6 ±1

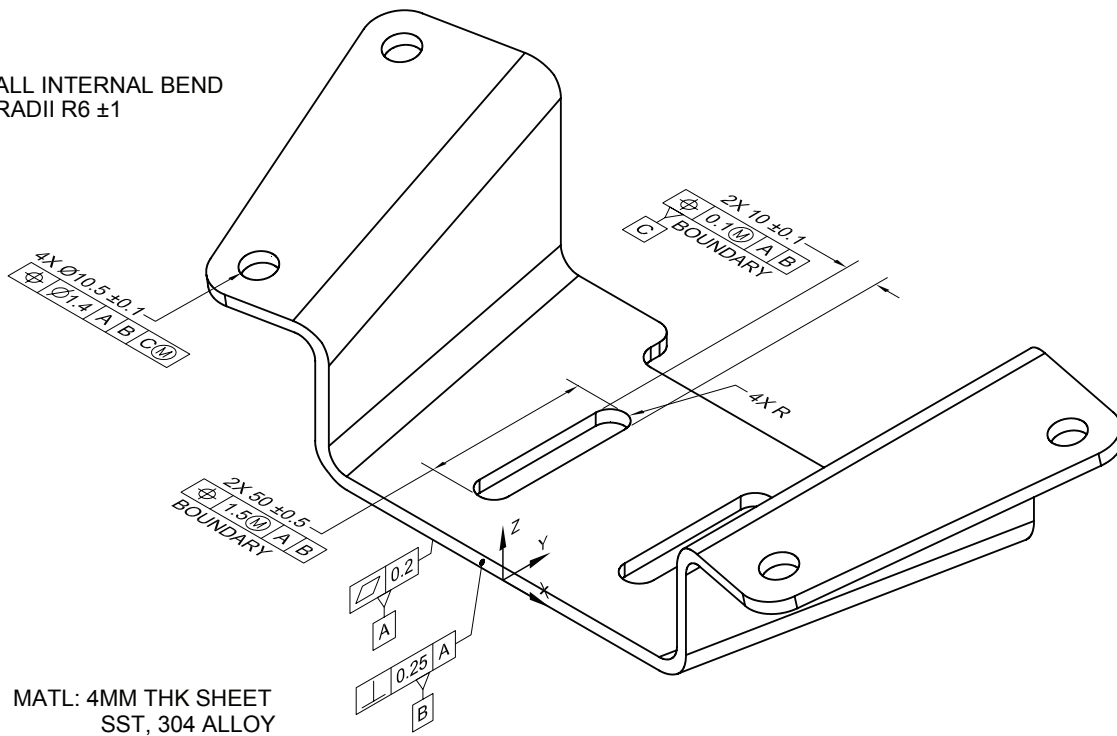

b. Datum Features and Position: Widths as Datum Feature C

SHEET METAL PART: POSITION AND BOUNDED DATUM FEATURES
FIGURE 26-76



Note:
Slots are incompletely dimensioned and toleranced for clarity.

ALL INTERNAL BEND
RADII R6 ±1

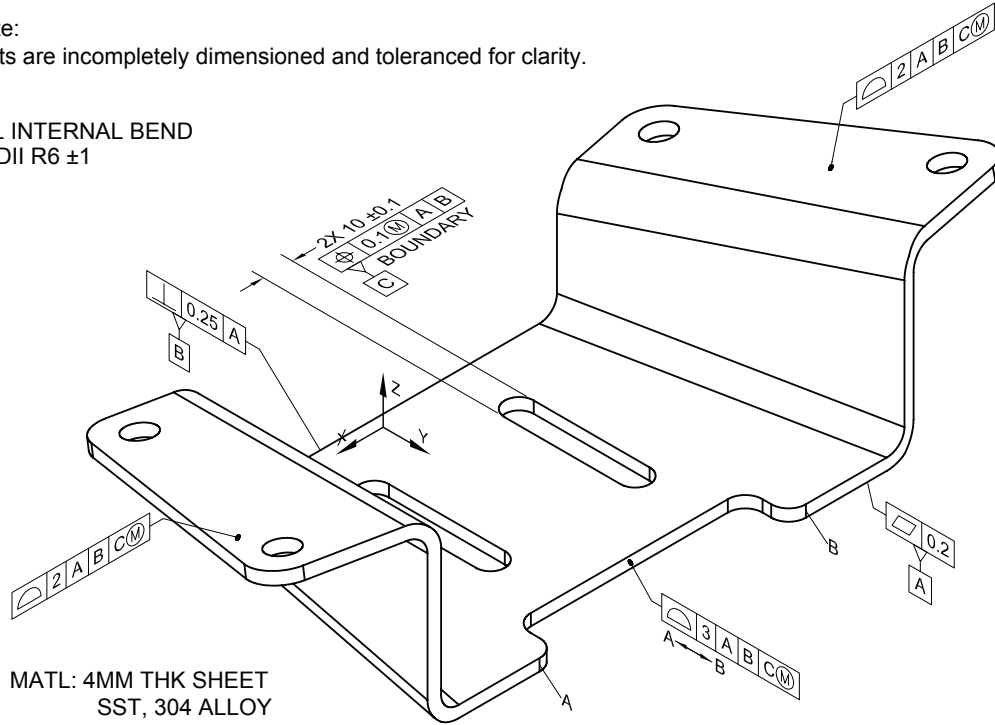

c. Equal-Bilateral Profile Tolerances

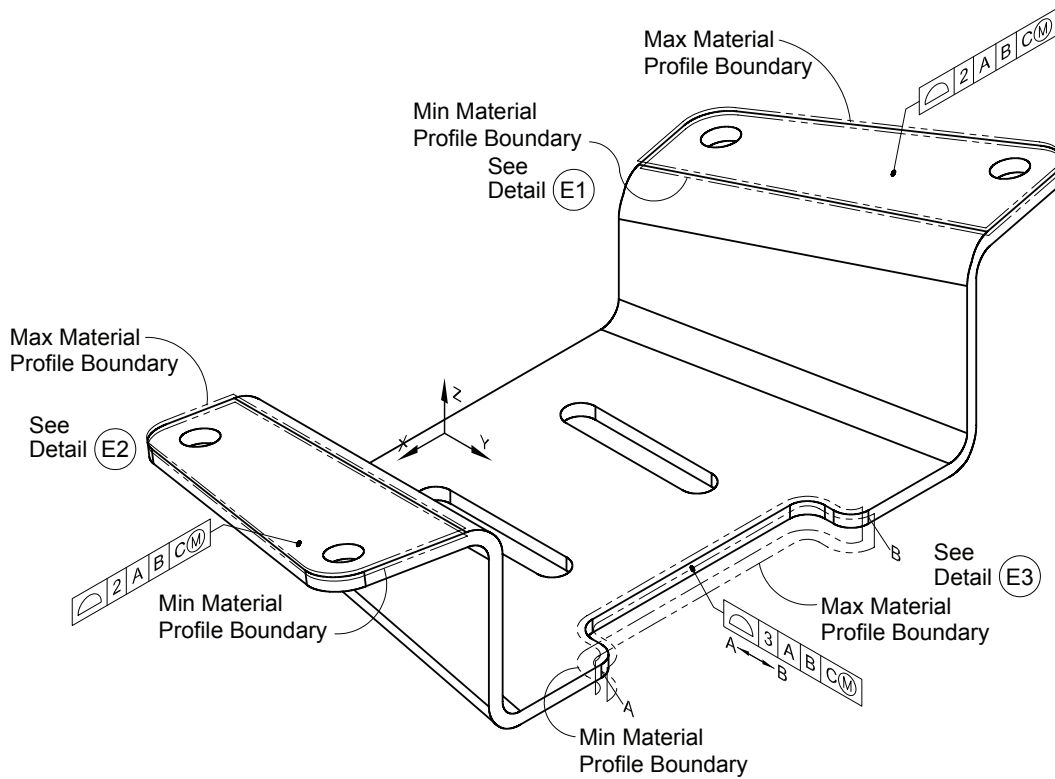

d. Equal-Bilateral Profile Tolerance Zones

SHEET METAL PART: PROFILE TOLERANCING
FIGURE 26-77

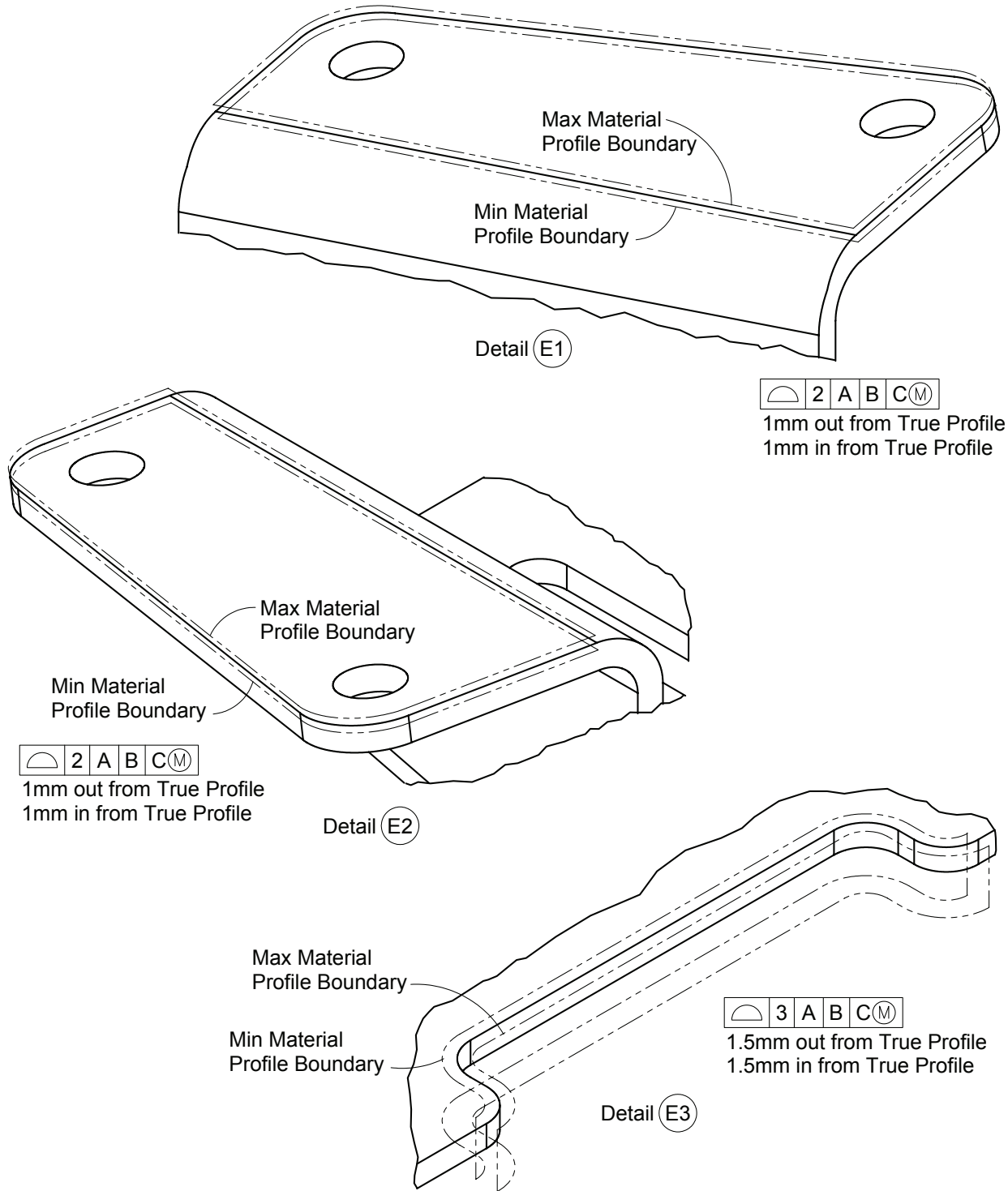

e. Equal-Bilateral Profile Tolerance Zones - Enlarged Details

SHEET METAL PART: PROFILE TOLERANCING
FIGURE 26-78

Note:
 Slots are incompletely dimensioned and toleranced for clarity.

ALL INTERNAL BEND
 RADII R6 ±1

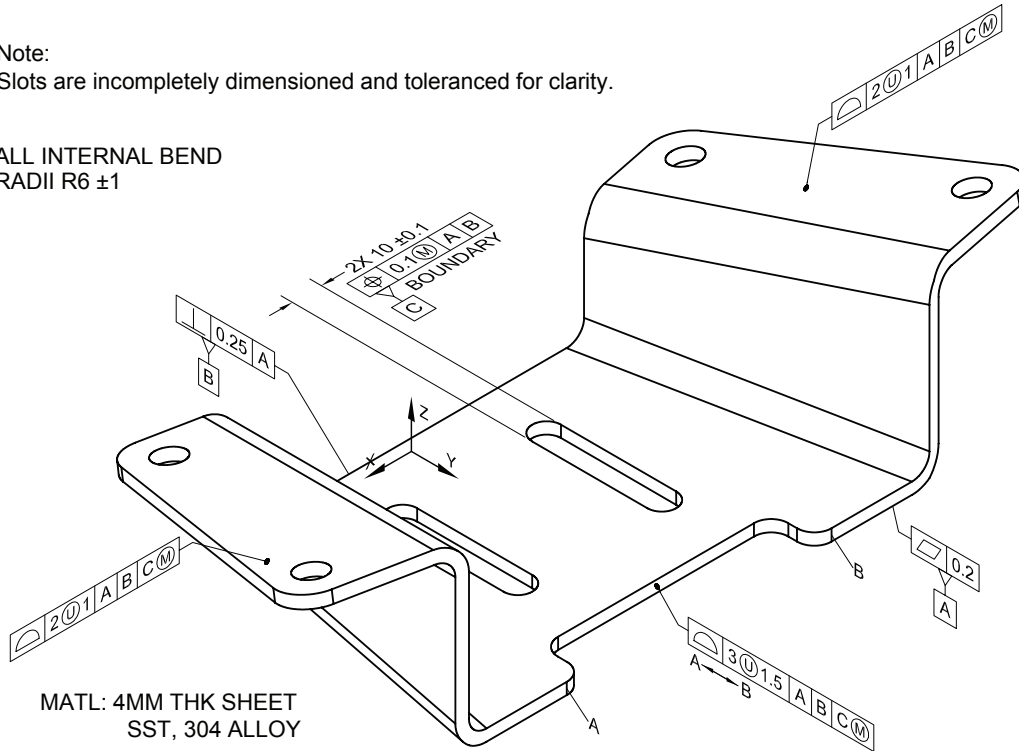

f. Equal-Bilateral Profile Tolerances with Unequally Disposed Modifier

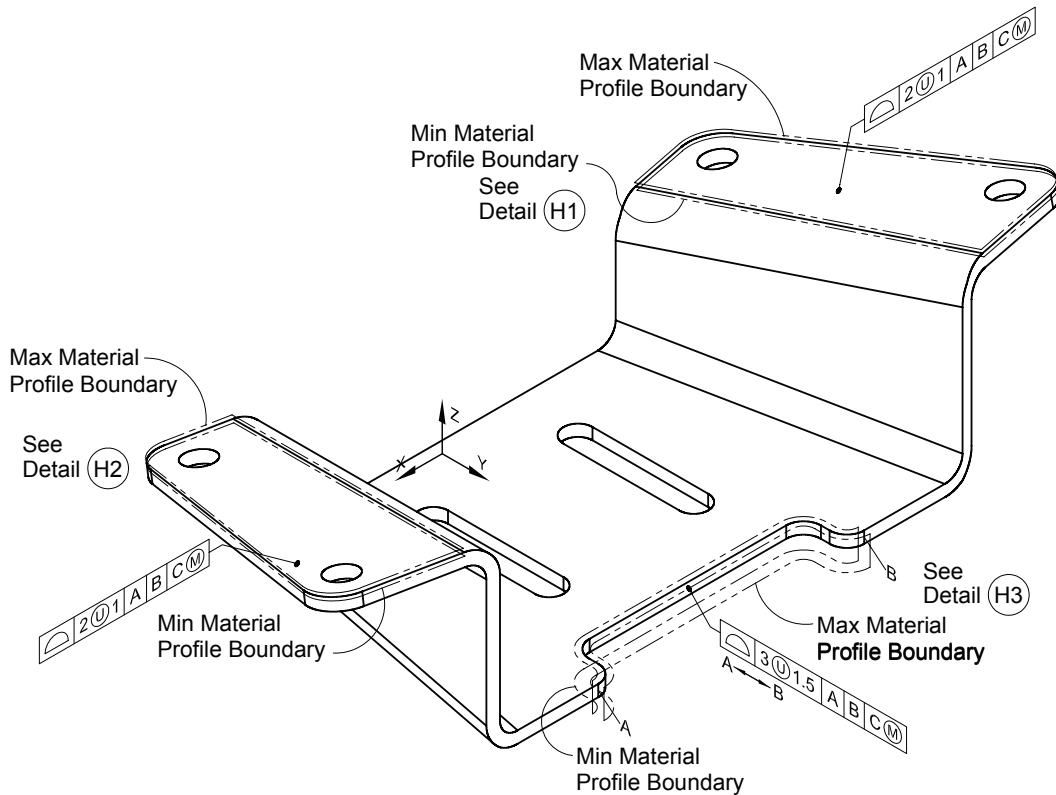

g. Equal-Bilateral Profile with Unequally Disposed Modifier - Tolerance Zones

SHEET METAL PART: PROFILE TOLERANCING
FIGURE 26-79

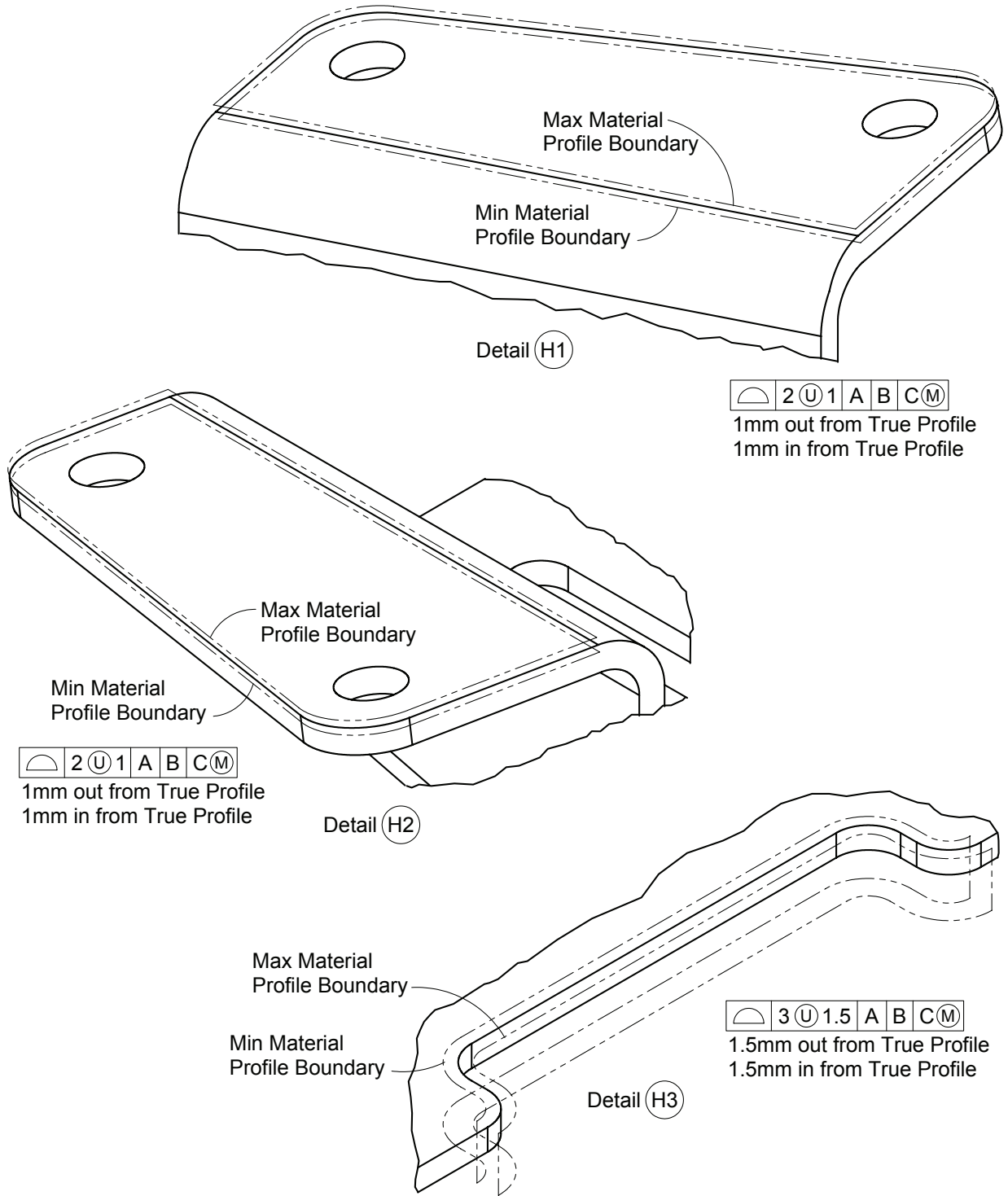

h. Equal-Bilateral Profile Tolerance Zones - Enlarged Details

SHEET METAL PART: PROFILE TOLERANCING
FIGURE 26-80

Note:
 Slots are incompletely dimensioned and toleranced for clarity.

ALL INTERNAL BEND
 RADII R6 ±1

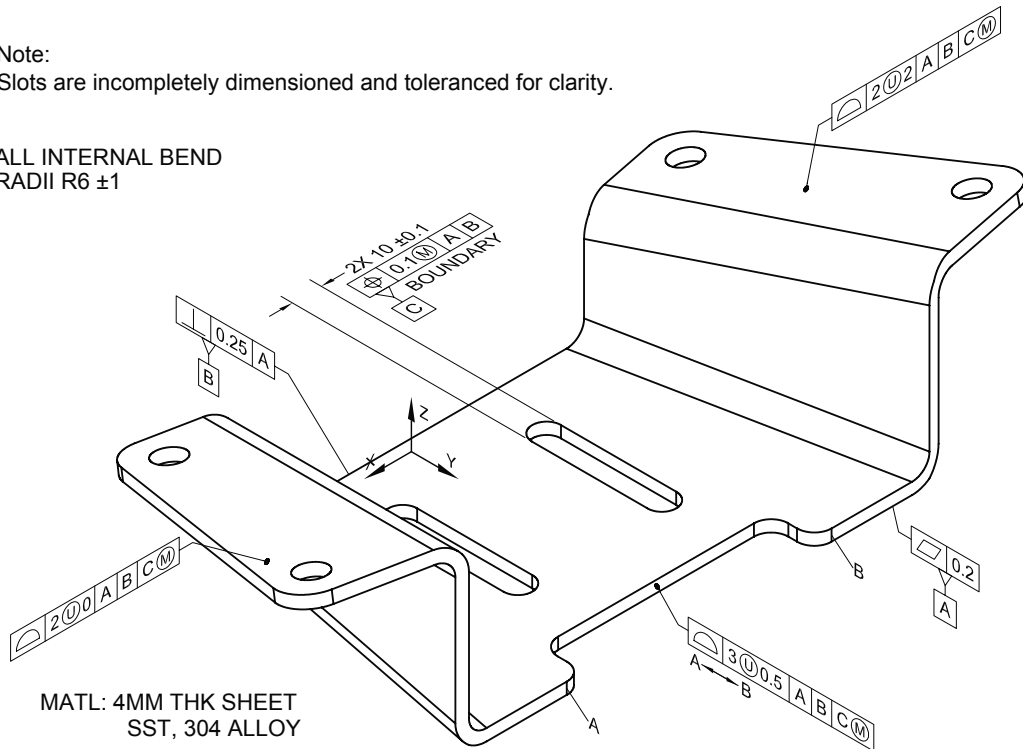

i. Unilateral and Unequal-Bilateral Profile Tolerances with Unequally Disposed Modifier

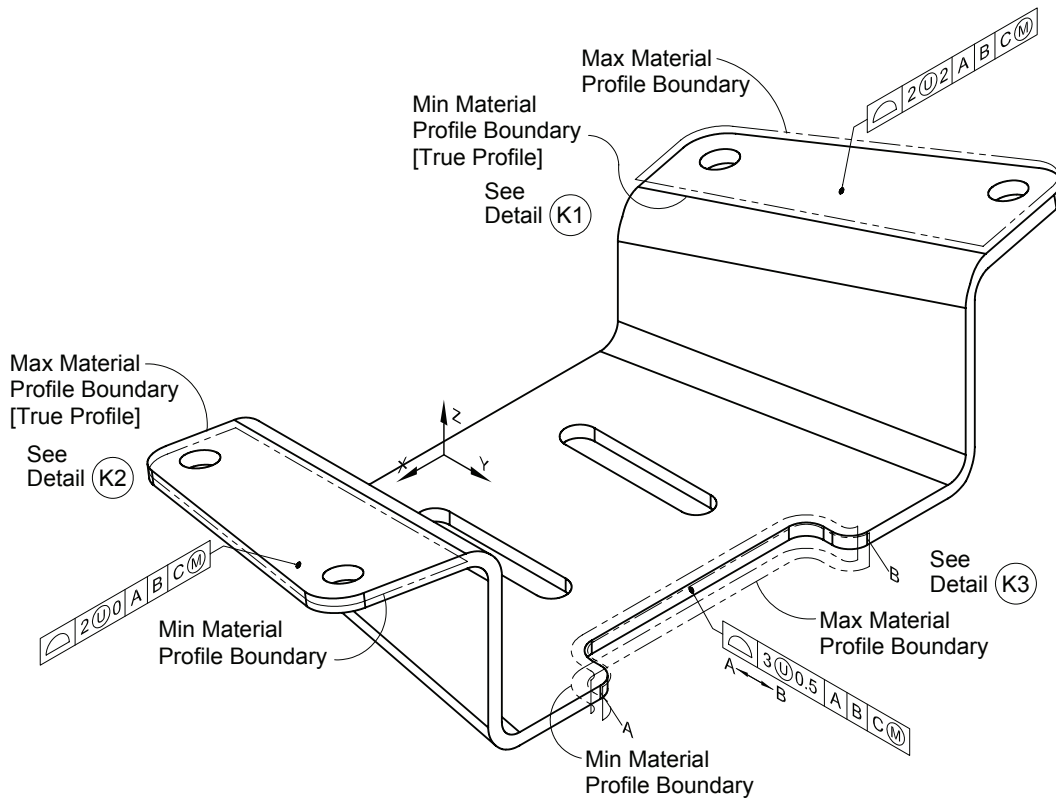

j. Unilateral and Unequal-Bilateral Profile with Unequally Disposed Modifier - Tolerance Zones

SHEET METAL PART: PROFILE TOLERANCING
FIGURE 26-81

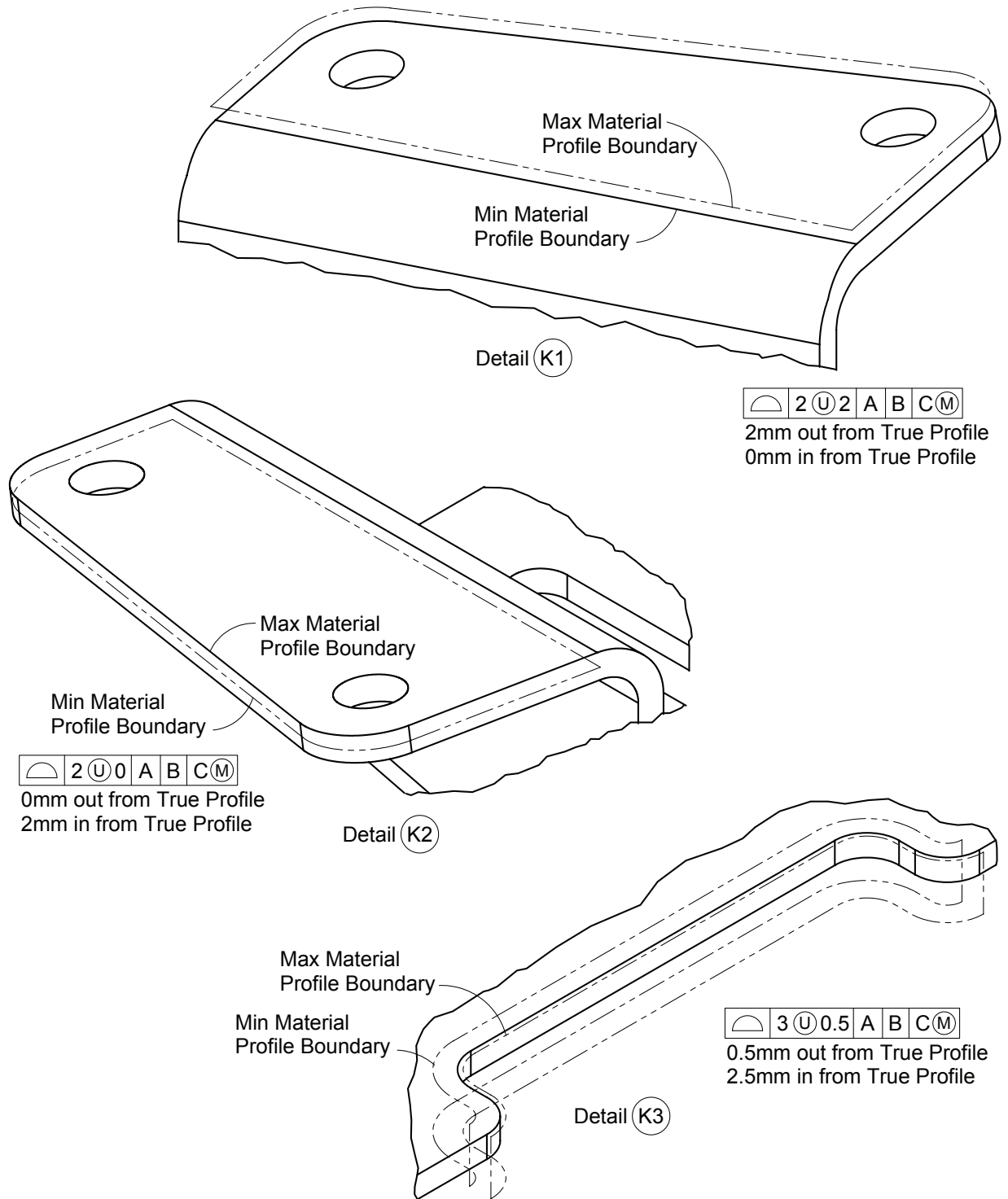

k. Unilateral and Unequal-Bilateral Profile Tolerance Zones - Enlarged Details

SHEET METAL PART: PROFILE TOLERANCING
 FIGURE 26-82



26.34 Additional Requirements for Using 3D Data in a Technical Data Package (TDP) from MIL-DTL-31000C. MIL-DTL-31000C includes significant new material addressing the use of 3D data in a Technical Data Package (TDP). In general this material is in complete agreement with ASME Y14.41-2003. However, there are several more restrictive statements in MIL-DTL-31000C regarding the use of 3D data in TDPs. A general synopsis and a detailed description of the changes related to 3D data in MIL-DTL-31000C follows.

26.34.1 Synopsis of Changes Related to Using 3D Data in a TDP from MIL-DTL-31000C. The major change to MIL-DTL-31000C was the addition of new material addressing three-dimensional (3D) digital data used as all or part of a TDP. With this recognition of the expanding role of 3D data, two new types of TDPs were required to differentiate between TDPs based on 2D and 3D data (Type 2D TDP and Type 3D TDP).

The coverage of 3D data in MIL-DTL-31000C parallels the shift in industry toward greater use of 3D data throughout the design-manufacturing-service lifecycle of a product, and thus is consistent with general trends in industry. Accordingly, an attempt to standardize the use of 3D data in industry has been addressed by the standard ASME Y14.41-2003. Careful review of the changes related to 3D data in MIL-DTL-31000C reveals an alignment between MIL-DTL-31000C and ASME Y14.41-2003.

26.34.2 Detail of Changes Related to Using 3D Data in a TDP from MIL-DTL-31000C. MIL-DTL-31000C includes several additional requirements for using of 2D and 3D data that are not found in ASME Y14.41-2003. The following are quotes from MIL-DTL-31000C:

1. "In general, solid models shall be in accordance with (ISO) 10303 Standard for the Exchange of Product model data (STEP), or in a native 3D CAD format capable of being exported to ISO 10303 STEP format."

Note: ISO 10303 is not referenced in ASME Y14.41-2003, and adherence to the STEP format defined in ISO 10303 is not required by ASME Y14.41-2003.

2. "When 3D TDP data is used, the solid models shall display classification marking clearly visible when the solid model is first opened."

Note: ASME Y14.41-2003 states that "the security marking shall be constantly displayed for all mediums of views" which is slightly different than requiring the classification markings to be visible when the solid model is first opened. However, the requirements in ASME Y14.41-2003 seem to include the requirement above.

3. A 3D TDP shall be of detail and content sufficient for the support of production, engineering and logistics support, and be based on fully parametric, computer based solid model and capable of generating, when specified, 2D engineering drawings."

Note: ASME Y14.41-2003 does not explicitly require models to be fully-parametric.

4. "Both Type 2D and Type 3D TDPs shall open in the appropriate software without regeneration errors or warnings."

Note: ASME Y14.41-2003 does not include this requirement.

5. "Data on 2D drawings based on the 3D solid models shall be sourced to the maximum extent possible from the 3D solid model. There shall be no conflict in data between the 3D solid model and its associated 2D drawing."

Note: ASME Y14.41-2003 does not explicitly state that 2D drawings should be sourced to the maximum extent possible from the 3D solid model. However, ASME Y14.41-2003 does lead the reader to this conclusion.