



22.1 SCOPE.

22.1.1 Purpose. This section establishes standard methods for preparing electrical and electronic drawings.

22.1.2 Conversion from the Use of Government Standards (DoD) to Non-Government Standards (NGS). Non-Government Standard ASME Y14.100-2004 including Appendices A thru E shall be used for engineering drawing practice as a replacement for government standard MIL-STD-100G. Whenever the use of ASME Y14.100 lacks the coverage covered by MIL-STD-100G in earlier or current revision levels to support DoD logistic systems and the identification of a Government agency as the design activity, the use of MIL-STD-100G may be allowed by the Government agency. Note that a waiver is no longer required to use the specifications and standards that remain in MIL-STD-100G. ASME Y14.100 is not a stand alone document for engineering drawing practices and should be used with ASME Y14.24, ASME Y14.34M, and ASME Y14.35M as a composite set; if necessary, this set may be used in conjunction with MIL-STD-100G as described above.

22.2 APPLICABLE DOCUMENTS. Note: DoD Policy Memo 05-3 “Elimination of Waivers to Cite Military Specifications and Standards in Solicitation and Contracts” has eliminated the need for waivers to use MIL-SPECS and MIL-STDS on DoD contracts. (See PREFACE 1, Section 2)

MIL-B-5087	Bonding, Electrical & Lighting Protection for Aerospace Systems (CNCLD Supsd by: MIL-STD-464)
MIL-W-5088	Wiring, Aircraft, Installation of (Supersedes: MIL-W-8160; Inactive for new design; Use SAE AS 50881)
MIL-PRF-5480	Data, Engineering and Technical Reproduction
MIL-E-6051	Electromagnetic Compatibility Requirements Systems (CNCLD Supsd by: MIL-STD-464)
MIL-W-8160	Wiring, Guided Missile, Installation of General Specification for (CNCLD Supsd by: MIL-W-5088; Use SAE AS 50881 for new design)
MIL-C-28809	Circuit Card Assemblies, Rigid, Flexible and Rigid-Flex (CNCLD: No S/S)
MIL-PRF-55110	Printed Wiring Board, Rigid, General Specification for (Supsd by MIL- PRF-31032A & Suppl 1)
MIL-PRF-31032A & Suppl 1	Printed Circuit Board/Printed Wiring Board, General Specification for
MIL-STD-100	Engineering Drawing Practices (CNCLD Supsd by: ASME Y14.100 & Appendices, ASME Y14.24, Y14.34M & Y14.35M)
MIL-STD-454	Standard General Requirements for Electronic Equipment (CNCLD Supsd by: MIL-HDBK-454)
MIL-HDBK-454	General Guidelines for Electronic Equipment
MIL-STD-464	Electromagnetic Environmental Effects Requirements for Systems
MIL-STD-681	Identification Coding and Application of Hook Up and Lead Wire
MIL-STD-889	Dissimilar Metals
MIL-STD-970	Standards and Specifications, Order of Preference for Selection of (CNCLD No S/S)
MIL-STD-1353	Electrical Connectors, Plug-in-Sockets & Associated Hardware, Selection & Use of

**22.2 APPLICABLE DOCUMENTS.** (Continued)

ANSI/IPC-T-50	Terms and Definitions For Interconnecting & Packaging Electrical Circuits (Supersedes: MIL-STD-429)
ASME Y14.5M	Dimensioning and Tolerancing
ANSI Y14.15	Electrical and Electronics Diagrams (CNCLD: No S/S)
ASME Y14.100	Engineering Drawing Practices
ANSI/ IEEE STD 91 /91A	Graphic Symbols for Logic Diagrams (X-Ref: ANSI Y32.14)
ANSI/ IEEE STD 200	Reference Designations for Electrical and Electronics Parts and Equipments (X-Ref: ANSI Y32.16)
ANSI/IEEE STD 280	Letter Symbols for Quantities Used in Electrical Science and Electrical Engineering (Same as ANSI Y10.5-1985)
ANSI/ IEEE STD 315 /315A	Graphic Symbols for Electrical and Electronics Diagrams (X-Ref: ANSI Y32.2)
IPC-D-325A	Documentation Requirements for Printed Boards
IPC-2221A	Generic Standard on Printed Board Design (Supersedes IPC-D-275)
IPC-2222	Sectional Design Standard for Rigid Organic Printed Boards (Supersedes IPC-D-275)
SAE AS 50881	Wiring, Aerospace Vehicle (Supersedes MIL-W-5088)

22.3 DEFINITIONS. (For Complete Coverage, See ANSI/IPC-T-50.)

22.3.1 Active Electronic Parts. Parts capable of controlling the flow of electrons without mechanical adjustment. This includes vacuum tubes and semi-conductor devices but excludes switches and variable resistors.

22.3.2 Block Diagram. Shows circuit information in a more simplified form than the Single Line Diagram. It represents the circuit functions by the means of single lines and rectangular blocks without using graphical symbols or reference designations. See FIGURE 22-2.

22.3.3 Cable Assembly. A cable of a definite continuous length having one or more ends processed or terminated in fittings which provide for connections to other items.

22.3.4 Circuit Card Assembly. A printed wiring board with separately manufactured parts such as resistors, capacitors, etc. mounted on it. It may or may not have plug-in connecting facilities attached either to the board or integrally etched, printed or deposited contacts. See FIGURE 22-15.

22.3.5 Color Coded Wiring. Wiring coated with insulation that is colored with a single color or a combination of colors for identification purposes.



22.3.6 Component Board Assembly. A terminal board upon which separately manufactured component parts have been mounted, e.g., resistors, capacitors, etc. (Boards with printed electrical conductor paths and components or paths only are not a part of this assembly.) See PARAGRAPHS 22.3.38 and 22.3.41.

22.3.7 Conductive Pattern. A design formed from any electrically conductive material on an insulating base.

22.3.8 Discrete Electronic Parts. A separate and distinct device, e.g. transistor, diode, resistor, etc.

22.3.9 Electrical And Electronic Reference Designations. Combinations of letters and numbers used to identify and locate items on diagrams and assemblies and for relating items in a set. Reference designations are not intended to replace other identifications such as part numbers.

22.3.10 Electrical And Electronic Symbols. Graphic representations of electrical or electronic parts. They are used in single line diagrams, schematics, or, if applicable, on connection or wiring diagrams.

22.3.11 Electrical Drawings. Related to power distribution, relays, motors, generators, etc.

22.3.12 Electrical Schematic Diagram. A drawing showing, by means of graphic symbols, the electrical connections and functions of a circuit arrangement. A schematic diagram does not show the size, shape or location of the component devices or parts.

22.3.13. Electronic Drawings. Related to electrical circuits in vacuum or gas-filled tubes and to solid state devices such as transistors, diodes, etc.

22.3.14 Element (Of a Microcircuit or Integrated Circuit). A constituent of the microcircuit or integrated circuit that contributes directly to its operation. (A discrete part incorporated into a microcircuit becomes an element of the microcircuit.)

22.3.15 Etching. A process wherein a printed pattern is formed by chemical or chemical and electrolytic removal of the unwanted portion of conductive material bonded to a base.

22.3.16 Film Integrated Circuit. An integrated circuit consisting of elements which are films formed in situ upon an insulating substrate.

22.3.17 Grid. An orthogonal network of equidistant lines providing the basis for an incremental location system.

22.3.18 Harness Assembly. Two or more insulated conductors grouped into a bundle or harness, held together by lacing or other similar binding.

22.3.19 Highway System. A method of diagramming in which wires are grouped into a single path, or "Highway", to conserve space and simplify the diagram.

22.3.20 Hybrid Microcircuit. A microcircuit consisting of elements which are a combination of the film circuit type and the semiconductor types or a combination of one or both of the types with discrete parts.

22.3.21 Indexing Holes. Holes placed in a printed circuit base material to enable the base to be positioned accurately for processing. (Indexing holes may or may not be on the finished board.)

22.3.22 Indexing Notches. Notches placed in the edge of printed circuit base material to enable accurate positioning of the base for processing. (Indexing notches may or may not be on the finished board.)

22.3.23 Integrated Circuit. A device in which a combination of inseparable associated circuit elements that are formed in place and interconnected on or within a single base material to perform a particular electrical function.



22.3.24 Interconnection Diagram. A drawing that shows only external wiring connections between units, sets, groups and systems.

22.3.25 Land. Use the term "Terminal Area."

22.3.26 Logic Diagram. A diagram that depicts, by logic symbols and supplementary notations, the details of signal flow and control, but not necessarily the point-to-point wiring existing in a system of two-state devices.

22.3.27 Master Artwork. An accurately scaled electronic data file(s) or alternative physical media that define the master image for each layer of a printed circuit board or printed wiring board. The master artwork is used to produce physical master media where required.

22.3.28 Master Drawing. A drawing showing the dimensional limits or grid location applicable to any or all parts of a printed wiring or printed circuit including the base.

22.3.29 Master Patterns. A line-to-line scale pattern (production negative) which is used to produce the printed wiring or printed circuit within the accuracy specified on the master drawing.

22.3.30 Microcircuit. A small circuit having a high equivalent circuit element density, which is considered as a single part composed of interconnected elements on or within a single substrate to perform an electronic circuit function. (This excludes printed wiring boards, circuit card assemblies and modules composed exclusively of discrete electronic parts.)

22.3.31 Microcircuit Module. An assembly of microcircuits, or an assembly of microcircuits and discrete parts, designed to perform one or more electronic circuit functions, and constructed such that for the purposes of specification testing, commerce, and maintenance, it is considered indivisible.

22.3.32 Microelectronics. That area of electronic technology associated with or applied to the realization of electronic systems from extremely small electronic parts or elements.

22.3.33 Monolithic Integrated Circuit. An integrated circuit consisting of elements formed in situ on or within a semiconductor substrate with at least one of the elements formed within the substrate.

22.3.34 Multichip Microcircuit. A microcircuit consisting of elements formed on or within two or more semiconductor chips which are separately attached to substrate.

22.3.35 Passive Electronic Parts. Parts that are non-active, and do not produce power or signal gain.

22.3.36 Plated Through Hole. An interfacial or interlayer connection formed by deposition of conductive material on the sides of a hole through the base.

22.3.37 Printed Circuit. A pattern composed of printed wiring and printed parts all formed on a common base. Also see IPC-T-50 for additional terms and definitions not included herein.

22.3.38 Printed Circuit Board. A printed board that provides both point-to-point connections and printed components in a predetermined arrangement on a common base.

22.3.39 Printed Component Part. A component part in printed form, such as a printed inductor, resistor, capacitor, transmission line, etc.

22.3.40 Printed Contact. A portion of printed wiring used for the purpose of providing electrical connection by pressure contact.

22.3.41 Printed Wiring Assembly. A wiring board upon which separately manufactured component parts have been added.

22.3.42 Printed Wiring Board. A printed board that provides point-to-point connections, but not printed components, in a predetermined arrangement on a common base.



22.3.43 Register. The relative position of one or more printed wiring patterns with respect to their desired locations on the base material.

22.3.44 Running (Wire) List. A book form drawing consisting of tabular data and instructions required to establish wiring connections within or between units of equipment, or between equipments, sets or assemblies of a system. A running (wire) list is a form of interconnection diagram or wiring diagram.

22.3.45 Single Line Diagram. Represents the circuit by means of single lines and simplified graphical symbols. A typical single line diagram is shown in FIGURE 22-1.

22.3.46 Substrate (Of A Microcircuit Or Integrated Circuit). The supporting material upon or within which the elements of a microcircuit or integrated circuit are fabricated or attached.

22.3.47 Terminal Area. A portion of a printed-circuit or printed wiring used for making electrical connections to the conductive pattern.

22.3.48 Terminal Board. An item usually consisting of insulating material designed specifically for, or on which are mounted, terminals such as screws, solder lugs, solder studs, etc. It does not include parts such as resistors, capacitors, etc.

22.3.49 Terminal Board Assembly. Two or more terminal boards, which are mounted on a common surface or to each other.

22.3.50 Terminal Pad. Use the term "Terminal Area."

22.3.51 Thin Film Circuits. Consist of parts, interconnecting conductor paths and provision for electrically connecting discrete active parts, normally deposited as thin films on a substrate.

22.3.52 Welded Module. A package of separately manufactured parts stacked between two or more insulating wafers with metal ribbons welded to the leads of the components rather than soldered interconnections. Finished product is normally encapsulated.

22.3.53 Wire Destination. A reference designation, with or without terminal identification, placed above and to the right of the wire number or color code to indicate the component to which the wire is routed.

22.3.54 Wire Numbers. Numbers or combinations of numbers and letters sequentially assigned to individual conductors on wiring diagrams for the purpose of identification. Wire numbers are not intended to replace other identification such as part numbers.

22.3.55 Wiring Diagram. A drawing showing electrical connections of an installation or its component devices or parts. It may show internal or external connections or both, and contains the detail necessary to make or trace the connections involved. Wiring diagrams usually show the general physical arrangement of the component devices or parts.

22.4 ELECTRICAL AND ELECTRONIC SCHEMATIC DIAGRAMS.

22.4.1 Schematic Diagram Description. Schematic diagrams are engineering reference documents and are not used for fabrication. The schematic diagram shows by means of graphic symbols and connecting lines the electrical connection and functions of a specific circuit arrangement. It facilitates tracing the circuit and its functions without regard to the actual size, shape or location of the components. The components are identified by reference designations and electrical values. See FIGURE 22-3.

22.4.1.1 Graphic Symbols Drafting Practices.

22.4.1.1.1 Symbol Representation. Symbols shall comply with ANSI/IEEE Std. 315 & Supplement 315A (ANSI Y32.2).



22.4.1.1.2 Position Of Symbol. The position of a symbol on a drawing does not alter its meaning.

22.4.1.1.3 Size Of Symbol. A symbol may be drawn to any proportionate size or line thickness and commensurate with drawing size to suit reproduction.

22.4.1.1.4 Electrical Symbols Shown With Power Off. Electrically operated devices are shown in a position with the power off. A note should be added to the drawing to indicate where devices are shown with power on.

22.4.1.1.5 Terminal Symbol. The terminal symbol (O) may be added for attachment of conductors to any of the part symbols.

22.4.1.1.6 Relationship Of Parts in a Symbol. Parts of a symbol for a device, such as a relay, may be shown separately on a circuit diagram provided designations are given to show the relationship of parts.

22.4.1.1.7 Switch Position. Switches are shown in a position with no operating force applied. Where there are two or more switch positions with no operating force applied or where switches are operated by a mechanical device, such as air pressure, a note is added to indicate the switch position.

22.4.1.1.8 Line Weight Of Symbols. Symbols are drawn in heavier weight lines than lines joining symbols.

22.4.1.2 Reference Designations Drafting Practices.

22.4.1.2.1 Reference Designation Representation. Reference designations shall comply with ANSI/ IEEE STD 200 (ANSI Y32.16).

22.4.1.2.2 Reference Designation Number Assignment. A complete reference designation is a combination of letters and numbers which identifies a part, subassembly, or unit of a set on diagrams, drawings, parts, lists, technical manuals, etc. The letters in a reference designation identify the class of item such as resistor, coil, electron tube or subassembly. The number differentiates between parts or subassemblies of the same class as illustrated below.

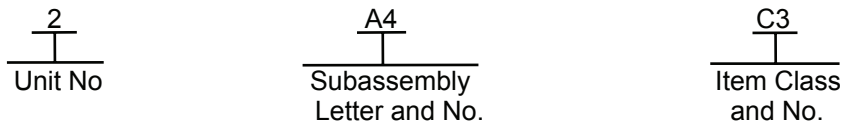

2A4C3 is CAPACITOR 3 of Subassembly A4 in Unit 2

22.4.1.2.3 Partial Reference Designation Number. Partial Reference designations may be used in accordance with ANSI/ IEEE STD 200 (ANSI Y32.16).

22.4.1.2.4 Reference Designation Identification. A reference designation is not an abbreviation for the name of an item.

22.4.1.2.5 Application Of Reference Designation Numbers. Reference designations initially should be assigned with the lowest number of each designation item class in the lower left hand corner of a schematic diagram and proceed from left to right in top to bottom order on the diagram. Numbers within each class shall start with 1 and run consecutively. See FIGURE 22-3.

22.4.1.2.6 Addition Of Information To Reference Designation. Additional information such as type designation, input or output, etc., may be added as shown in the example below:

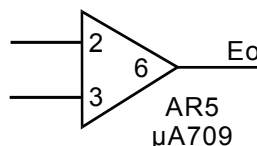



22.4.1.3 Component Numerical Values.

22.4.1.3.1 Numerical Values Expressed By Whole Numbers And Decimals. The values of capacitance, inductance and resistance are designated by whole numbers, or whole numbers and decimals. For example:

Use .092 μ F (microfarad) not 92 000 pF (picofarads)
5 mH (millihenry) not 0.005 H (henrys)
2.5 K (kilohms) not 2500 (ohms)

22.4.1.3.2 Omission Of Comma. The comma is omitted in values of four or more digits. Repetition of component values should be eliminated through the use of general notes:

- X. RESISTANCE IN OHMS, UNLESS OTHERWISE SPECIFIED.
- X. CAPACITANCE IN PICO FARADS, UNLESS OTHERWISE SPECIFIED.
- X. CAPACITANCE IN MICRO FARADS AND RESISTANCE IN OHMS, UNLESS OTHERWISE SPECIFIED.
- X. ALL RESISTOR VALUES ARE IN OHMS \pm ____% AND ARE _____ WATT, UNLESS OTHERWISE SPECIFIED.
- X. ALL CAPACITOR VALUES ARE IN MICRO FARADS \pm _____% AND ARE _____VDC, UNLESS OTHERWISE SPECIFIED.

22.4.1.4 Additional Part Information. May be included next to the graphical symbols, or as a note, or tabulated in a chart on a schematic diagram. Resistors may specify wattage ratings and tolerance, capacitors' working voltage and polarity, inductors' direct current resistance or impedance, transformers' voltage and current rating of each winding, and switches' and connectors' voltage and current rating.

22.4.1.5 An Equipment List. May be shown for reference only. If used, it is not to appear in the same area as a parts list. Except in special cases when it is deemed useful, schematics should omit equipment lists.

22.5 WIRING DIAGRAM.

22.5.1 Wiring Diagram. Shows general physical arrangement of the parts; reference designations are identical with the schematic except that sockets will use the same referenced designation as the parts inserted in them and prefixed with "X"; lines represent the wiring between parts. It may cover internal or external connections or both and contains the necessary detail to make or trace the connections involved. It is a supplementary document to the assembly drawing, containing all wire connection information, but does not have a parts list. The wiring diagram may be shown on the assembly drawing if practical. See FIGURE 22-4.

22.5.1.1 Part Representation. Parts on the wiring diagram are shown by a physical outline of the part, suggestive of its appearance, but confined to bare essentials and terminal identification (as viewed from wiring side). See FIGURE 22-4.

22.5.1.2 Part Terminal Identification. Wiring diagrams show detailed terminal identification of each part. If the terminals on the part are identified, these identifications are used. If the terminals on the part are not identified, sufficient detail is shown to permit ready identification of all terminals. Where the schematic diagram identifies terminals, the wiring diagram will show identical terminal identification.

22.5.1.2.1 Lead Identification. The leads of transistors, diodes, electrolytic capacitors, other semiconductor devices and batteries shall have their identification of polarity indicated on the wiring diagram to aid in terminal identification.



22.5.2 Reference Designations.

22.5.2.1 Location On Wiring Diagrams. Placed on the wiring diagram below or alongside the component symbol, preferably to the right side.

22.5.2.2 Designation Of Sockets Or Fuse Holders. Identified by a composite designation of letter "X" and the designation identifying the associated part. For example, the socket for electron tube V6 would be identified XV6. Only the designations for the sockets or fuse holders are given and not those for the parts which plug into them.

22.5.3 Conductor Identification.

22.5.3.1 Wire Identification. Wires are identified on wiring diagrams by one of three methods as explained in the following paragraphs. Only one method will be utilized on a group of drawings prepared for a specific project.

22.5.3.1.1 Color Code Identification. To be in accordance with MIL-STD-681, Color Code Identification may be used on either point-to-point or highway type diagrams. System I, II, III, or IV may be selected for use, but once a system has been selected, it will be utilized for all drawings in the set. A note on the drawing will invoke the standard and the system selected. See FIGURE 22-4.

22.5.3.1.2 Wire Numbers. Consist of sequentially assigned numerals starting with "1", or preferably, sequentially assigned numerals with a suffix letter, and may be used on either point-to-point or highway type diagrams. If numerals only are used, a new number is assigned to each wire segment regardless of potential. If the preferred method is used, all wires of the same potential (i.e., having common connections) are assigned the same number with a different suffix letter, starting with "A", for each wire segment. The number is changed and a new suffix sequence is started when the circuit passes through an active or passive electrical component. See FIGURE 22-5.

22.5.3.1.3 Wire Numbers Per SAE AS 50881 Superseding MIL-W-5088. Used on either point-to-point or highway type diagrams. This method provides a significant numbering system identifying circuit function, unit number, etc., and should be utilized only when a contractual or other specific requirement exists. A note on the drawing will invoke this specification when it is used for wire numbering.

22.5.3.2 Wire Number Or Color Code. Place in a break in the conductor line. The wire destination (indicated by reference designation) is placed to the right and above the wire number or color coding. Wire destinations are required when the highway system is used, and lines going into highways must curve in the direction of the component to which they are routed. All wires including jumpers are identified. See FIGURE 22-4.

22.5.4 Wire Table. A tabulation of all wires including jumpers. It may be included on diagrams but is required only when all wires are being assigned dash numbers of the mechanical assembly drawing. When shown, a wire table lists the wire dash number, wire identification, and wire size as a minimum. See FIGURE 22-4.

22.5.4.1 Equipment List. Equipment List may be shown on a wiring diagram if it conforms to the requirements specified in PARAGRAPH 22.4.1.5.

22.6 ELECTRICAL OR ELECTRONIC ASSEMBLY DRAWING.

22.6.1 Electrical Or Electronic Assembly Drawing. Meets all the requirements of an assembly drawing as described in Section 4. In addition, it must also include or reference the schematic and wiring diagram or wire list in the general notes. See FIGURE 22-8.

22.7 ELECTRICAL OR ELECTRONIC DETAIL DRAWING.

22.7.1 Electrical Or Electronic Detail Drawing. Meets all the requirements of a mechanical detail drawing as described in Section 4. See FIGURE 22-7.



22.7.2 Selection of Parts and Materials. Parts and materials covered by documents listed in SAE AS 50881 are standard and shall be used whenever they are suitable for the purpose. Parts and materials shall be procured from QPL sources when they exist. Nonstandard parts and materials must be equivalent to or better than similar standard parts and materials. When this specification fails to provide an applicable specification or standard, the contractor shall use other established specifications or standards. Parts and materials selected from other than this specification are not standard, and approval must be obtained prior to their use in aerospace vehicles. Each vendor source for a nonstandard part or material requires approval. When a nonstandard part is used where a suitable standard part exists, the contractor shall reference the standard part on the drawing, parts list or data package, and the installation shall provide for replacement with the standard part.

22.7.3 Wiring Installation. Design of the wiring installation shall conform to the following precedence:

- | | |
|-----|---|
| 1st | Safety in flight (where applicable) |
| 2nd | The ease of maintenance, removal and replacement of the wiring. |
| 3rd | Cost effective aircraft production (where applicable) |

Wiring shall be fabricated and installed so as to achieve the following:

- a. Maximum reliability.
- b. Minimum interference and coupling between systems.
- c. Accessibility for inspection and maintenance.
- d. Prevention of damage.

The ease of maintenance, removal and complete replacement of wire harnesses shall be given consideration in the wiring design.

22.7.4 Wire Protection and Support. Wiring shall be supported to meet the following requirements:

- a. Prevent chafing.
- b. Secure wiring where routed through bulkheads and structural members.
- c. Properly group, support and route wiring in junction boxes, panels and bundles.
- d. Prevent mechanical strain or work hardening that tends to break conductors and connections.
- e. Prevent arcing or overheated wiring from causing damage to mechanical control cables, and associated moving equipment.
- f. Facilitate reassembly to equipment terminal boards.
- g. Prevent interference between wiring and other equipment.
- h. Provide support for wiring to prevent excessive movement in areas of high vibration.
- i. Dress the wiring at connectors and terminating devices in the direction of the run without deformation of grommet seals.

22.7.5 Ground Return. Electrical power source ground terminals shall be connected to the primary metallic structure of the vehicle. The vehicle structure shall serve as the ground return circuit unless system considerations require separate ground return wiring. Equipment that incorporates a ground terminal shall be grounded by the shortest suitable ground wire. Equipment that is internally grounded and that does not incorporate a ground terminal shall be grounded by the shortest practicable ground wire if suitable grounding is not provided by the equipment mounts, or if corrosion of the mounts is likely to occur. Ground return wiring shall not be connected to magnesium. Bonding shall be in accordance with MIL-STD-464.



22.7.6 Conduit. Conduit may be used where necessary to protect wiring or to facilitate maintenance in inaccessible areas. Use of conduit requires procuring activity approval unless specifically required elsewhere in SAE AS 50881. Metallic conduit may be used for shielding to meet the requirements of MIL-STD-464, subject to approval by the procuring activity.

22.7.7 Connectors. Selection and use of electrical connectors and associated hardware shall be in accordance with MIL-STD-1353. Connectors shall be environment resisting. Except for hermetic connectors with only pin type design, connectors shall be selected so that contacts on the "live" or "hot" side of the connection are socket type rather than pin type to minimize personnel hazard and to prevent accidental shorting of live circuits when the connector is unmated. When using special contacts such as the thermocouple or coaxial, circular electrical connectors shall be specified on installation drawings using the A and B suffix when applicable in the connector part number. The "A" designation without pins and the "B" designation without sockets, indicate special applications for the connector.

22.7.8 Junctions. An uninterrupted wire is generally preferable to a junction. Only approved devices, such as permanent splices, feed-through bushings, headers, terminal blocks, terminal junction systems and connectors shall be used for wire junctions. The need and choice of junctions shall be determined by consideration of reliability factors, maintenance factors and manufacturing procedures, in that order of selection. Solderless junctions are preferred. The use of solder junctions shall be kept to a minimum.

22.7.9 Junction Boxes. Junction boxes may be used to provide special protection for wire and cable junctions.

22.7.10 Wire Splices. Insulated in-line wire splices may be used to assemble subassemblies, to incorporate changes or to facilitate repairs and maintenance.

22.7.11 Terminal Lugs. Wire terminal lugs shall be used to connect wiring to terminal block studs or equipment terminal studs. No more than four terminal lugs or three terminal lugs and a bus shall be connected to any one stud (total number of terminal lugs per stud includes a common bus bar joining adjacent studs. Four terminal lugs plus a common bus bar thus are not permitted on one stud). When the terminal lugs attached to a stud vary in diameter, the greatest diameter shall be placed on the bottom and the smallest diameter on top. Terminal lugs shall be selected with a stud hole diameter which matches the diameter of the stud. Tightening terminal connections shall not deform the terminal lugs or the studs. Terminal lugs shall be so positioned that bending of the terminal lug is not required to remove the fastening screw or nut, and movement of the terminal lugs will tend to tighten the connection.

22.7.12 Terminal Boards and Terminal Junction Modules. Terminal boards or terminal junction modules shall be used for junctions of wiring requiring infrequent disconnection or for joining two or more wires to a common point.

22.8 CABLE ASSEMBLY DRAWING.

22.8.1 Cable Assembly Drawing. An assembly drawing containing all of the necessary information to fabricate a finished cable. The wiring diagram is usually an integral part of the drawing. A parts list is included, and reference designations required to be marked on components are shown. Single usage cables have mating connector reference designations marked in parentheses on each connector. See FIGURE 22-8.

22.8.2 Wire and Cable Identification. Each wire and cable shall be marked with an identification code on the jacket or sleeving of the wire and cable. Hot stamp marking of wire and cable shall not be used unless other marking methods are not compatible with wire or cable insulation.

22.8.3 Assignment of Identification Code. The identification code for wiring shall be significant or nonsignificant in accordance with SAE AS 50881, as specified by the procuring activity.



22.9 WIRING HARNESS DRAWING.

22.9.1 Wiring Harness Drawing. All dimensions necessary are shown to define the harness form and termination points, or a grid system may be used in lieu of dimensions. The drawing shall also include a wire data tabulation of wire numbers, circuit reference designations, color codes, lengths, parts list, and other data, as necessary. Instructions or references thereto should be included in note form for the preparation and installation of the harness, associated schematic diagram, and the wiring diagram. See FIGURE 22-9.

22.9.1.1 Harness Preference. Harnesses shall be either open or protected design. Open harnesses are preferred for maintenance considerations. Harnesses may be designed to meet mechanical or shielding requirements. The use of protected harnesses shall be avoided unless wiring design considerations dictate their use and is subject to the approval of the procuring activity. The design details of protected harnesses are also subject to the approval of the procuring activity.

22.10 INTERCONNECTION DIAGRAM.

22.10.1 Interconnection Diagram Presentation. Units are shown as phantom-lined rectangular boxes omitting all internal circuitry. Interconnecting wiring or harness assemblies are shown in wiring diagram fashion. All part subassemblies and wiring harness are identified by referencing their part numbers. See PARAGRAPH 22.3.24 and FIGURE 22-10.

22.10.2 Interconnection Diagram Validity. The Interconnection Diagram is acceptable as a final assembly drawing for some contracts. When it is contractually acceptable, the drawing is not a reference document and must meet all other requirements for an assembly drawing.

22.11 PRINTED CIRCUITS AND PRINTED WIRING.

22.11.1 Printed Circuit and Printed Wiring Drawings. The following drawings which comply with MIL-PRF-31032A & Suppl. 1, IPC-D-325A, IPC-2221A and IPC-2222 are required to develop and document the design of a circuit card assembly: master artwork, board detail or master drawing, assembly drawing and schematic diagram. The master drawing and the master pattern drawing may be separate sheets of the same drawing.

22.11.1.1 Layout Drawing For Positioning Items (Optional). A layout may be necessary to determine component and circuit positioning, but is not a required drawing. The layout is normally created to a 4:1 or 2:1 scale on a stable base material such as matte surface Mylar drawing film. It may be preprinted with appropriate size grid spacing or used with a gridded underlay.

22.11.1.2 Printed Circuit/Wiring Board Master Drawing. Once the location of the components and the routing of the conductors are determined on the layout, a printed circuit/wiring board master drawing is drawn to the same scale and on the same standard grid spacing. It is an accurate drawing of the conductor pattern and shows all the printed conductors, terminal areas, edges of the board, mounting and indexing holes (see FIGURE 22-12 and -13) and all conductive areas that will appear on the finished board. Reference designations are to be shown if they are etched. The master drawing may be prepared manually or electronically.

22.11.2 Master Pattern. The master pattern is a precise 1:1 scale pattern which is used to produce the printed wiring or printed circuit within the accuracy specified on the master drawing. It may be an electronic file or a contact or reduced reproducible of the original master artwork prepared on a stable media. See FIGURE 22-11.

22.11.2.1 Requirements For Master Artwork. Master artwork may be prepared electronically or on physical media. Master artwork prepared using either method may be used to develop the master pattern and master drawing, which may also be electronic or manually-prepared. Where master artwork is manually-prepared, the master artwork is prepared on stable material using black pressure sensitive tape and pre-cut shapes (FIGURE 22-16); the entire conductive pattern must conform to MIL-PRF-31032A & Suppl. 1, IPC-D-325A, IPC-2221A and IPC-2222. For manually-prepared drawings, identification markings to be etched on the board and information for the drawing, other than conductive patterns, may be done with ink. Separate views are prepared for each side of double-sided boards.



12.11.2.1 (Continued)

Grids spaced at .100, .050 or .025, either preprinted on the drawing material or on an underlay, are utilized. All terminal areas, mounting holes, test points, etc. are located on grid intersections or are dimensioned from a hole on a grid intersection. Board edges are located on grid lines or dimensioned from holes that are on grid lines. Unless otherwise specified on the master drawing (board detail), the accuracy for locating terminal areas on the tape master must be such that the resulting pattern on the printed wiring board is positioned within .010 diameter. Trim marks for the board outline are approximately .125, wide, with the inside edge representing the trim line, and are normally shown only at the corners. In all cases, regardless of size and board complexity, where the drawings are to comply with ASME Y14.100, two (2) reduction dimensions will be required on the master artwork drawing for the purpose of reproduction to full scale. For further definition of trammel points, see PARAGRAPH 22.11.4.1. Three indexing holes or notches are required and are used to locate the board for drilling holes. On double-sided boards the indexing holes or notches must match within .005 inch. Two indexing holes (or notches) are located on a line parallel to the long dimension of the board and the third is located on a line perpendicular to the first line and in line with one of the first two holes. Indexing holes are located as far apart as practical and with different dimensions between holes in the two perpendicular directions.

22.11.2.2 Application Of Tape to Physical Media. The pressure sensitive black tape for the conductive pattern is applied without tension to minimize creepage. Tape should be overlapped to avoid gaps which would cause discontinuity in the conductor. Bends 90° or greater with bend radii smaller than those in the tabulation below are to be made with precut radius tape.

TAPE WIDTH ON DRAWING		RECOMMENDED BEND RADIUS FOR 90° BENDS	
INCH	METRIC	INCH	METRIC
.125	3.18	1.00	25.4
.187	4.75	2.00	50.8
.250	6.35	3.00	76.2
.312	7.94	4.00	101.6
.375	9.52	5.00	127.0
.438	11.11	6.00	152.4

22.11.2.2.1 Conductors Having Exterior And Interior Corners Less Than 90° Included Angle. All conductors having exterior and interior corners less than 90 degrees included angle shall be rounded and filleted as shown below.

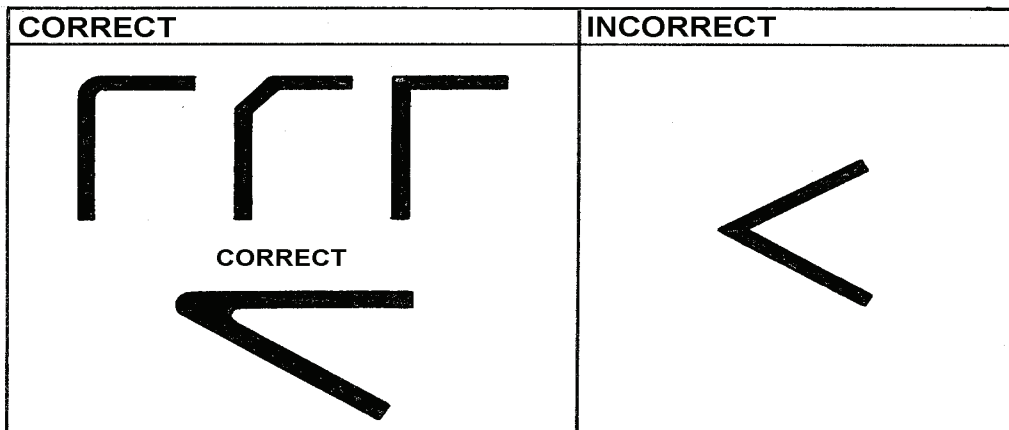

CONDUCTOR CORNERS



22.11.2.2.2 Length Of The Conductor Between Various Terminal Areas. The length of the conductor between various terminal areas shall be held to a minimum, consistent with other design requirements as shown below.

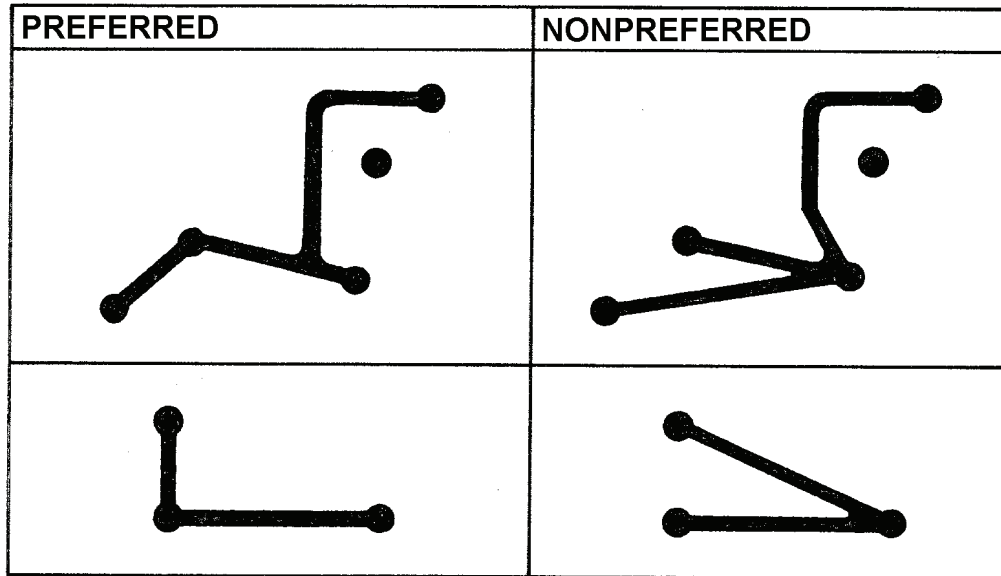

CONDUCTOR PATTERN (SHORTEST DISTANCE)

22.11.2.2.3 Minimum Spacing. The minimum spacing between conductors, between conductor patterns, and between conductive materials (such as conductive markings or mounting hardware) and conductors shall be in accordance with TABLES 22-1, 22-2, or 22-3. The minimum spacing between the conductive patterns and the edge of the printed wiring board or the printed wiring board guides shall be .025 inch; however, this is not applicable to edge board connectors or ground planes. Larger spacings shall be used whenever possible.

22.11.2.2.4 Minimum Spacing Between Conductors Used Under 10,000 Feet. The minimum spacing between conductors on uncoated printed wiring boards at sea level to altitudes up to and including 10,000 feet shall be in accordance with TABLE 22-1.

Voltage between conductors DC or AC peak (volts)	Minimum spacing	
	INCH	METRIC
0-150	.025	0.64
151-300	.050	1.27
301-500	.100	2.54
Greater than 500	.0002 inch per volt	0.00508 mm per volt

CONDUCTOR SPACING (UNCOATED PRINTED WIRING BOARDS)
(SEA LEVEL THROUGH 10,000 FT)

TABLE 22-1



22.11.2.2.5 Minimum Spacing Between Conductors Used Above 10,000 Feet. The minimum spacing between conductors on uncoated printed wiring boards shall be in accordance with TABLE 22-2 when the printed wiring boards are subjected to reduced pressure equivalent to altitudes greater than 10,000 feet.

Voltage between conductors DC or AC peak (volts)	Minimum spacing	
	INCH	METRIC
0-50	.025	0.64
51-100	.060	1.52
101-170	.125	3.18
171-250	.250	6.35
251-500	.500	12.7
Greater than 500	.001 inch per volt	0.025 mm per volt

CONDUCTOR SPACING (UNCOATED PRINTED WIRING BOARDS)
(OVER 10,000 FT)
 TABLE 22-2

22.11.2.2.6 Minimum Spacing Between Conductors On Coated Printed Wiring Boards. The minimum spacing between conductors on coated printed wiring boards shall be as indicated in TABLE 22-3.

Voltage between conductors DC or AC peak (volts)	Minimum spacing	
	INCH	METRIC
0-30	.010	0.25
31-50	.015	0.38
51-100	.020	0.51
101-300	.030	0.76
301-500	.060	1.52
Greater than 500	.00012 inch per volt	0.00305 mm per volt

CONDUCTOR SPACING (CONFORMAL COATED PRINTED WIRING BOARDS)
(APPLICABLE TO ALL ALTITUDES)
 TABLE 22-3

22.11.2.3 Care Of Master Artwork. After the necessary contact reproducible copies of the tape master have been prepared, the master artwork should be stored flat if it is being retained. The drawing number may be removed, and stored for future use in a similar design or for possible revision to the same drawing.

22.11.2.4 Conductor Patterns. Show as viewed from the component side. Double-sided boards will be identified as "Side 1" and "Side 2." The reference designation of the assembly, trademarks, assembly part numbers and other desirable information may be shown on the master artwork if it is to be etched on the board. Assembly reference designations, part identification and trademarks are located so they will be visible when assembled in the unit.

22.11.2.5 Plated Through Holes. These require a terminal area on both sides of the board. Large conductive areas, required for shielding or other reasons, must be broken up into a gridwork or other pattern that will make the conductive pattern continuous. The maximum unbroken conductor area should be no larger than can be covered by a .500 diameter circle at 1:1. When boards utilize a portion of the conductor pattern as male contacts to mate with a connector receptacle, the contacts must be extended at least .030-inch beyond the board outline and be joined together outside the board outline by one continuous strip of conductor material 1-inch wide at 4:1 to aid in plating.



22.11.2.6 Terminal Area Diameter For Unsupported Holes (Plated or Not Plated Through). A minimum of .040 diameter larger than the diameter of the hole in the terminal area is required. For plated through holes, the terminal area must be a minimum of .020 diameter larger than the diameter of the hole. Larger terminal areas are desirable. It should be kept in mind that after considering all manufacturing tolerances, the minimum acceptable width of the annular ring of conductive material around an unsupported hole is .015, and for plated through holes, the minimum width is .005.

22.11.2.7 Changes To A Master Artwork Drawing. Made only by direct drawing change utilizing a drawing change notice (DCN).

22.11.3 Master Drawing. A master drawing is one that shows the dimensional limits or grid location applicable to any or all parts of a printed circuit or printed wiring, including the base. All permanently attached hardware such as nonremovable terminals, eyelets, soldered clips or sockets, etc. are included on this drawing. Electronic parts and removable hardware are not included. See FIGURE 22-14.

22.11.3.1 General Requirements, Master Drawing. The master drawing in accordance with IPC-2221A and IPC-2222 establishes the size and shape of the board, the size and location of all holes therein, the shape and arrangement of both conductor and nonconductor patterns or elements, with separate views on each side of double-sided or multilayer boards. Any pattern features not controlled by hole sizes and locations must be dimensioned. All Locations are dimensioned by use of a modular grid system with grid spacing of .100, .050, or .025 inch, in that order of preference. The accuracy of the resulting hole pattern on the printed wiring board shall have all centers located within .005 inch radius of the positional tolerance indicated by the grid location or dimensioned location. Dimensioning and tolerancing practices shall be in accordance with ASME Y14.5M-1994 (or applicable year). See IPC-2221A for more information on relevant dimensioning and tolerancing practices.

22.11.3.2 Master Assembly Drawing (Circuit Card Assembly). A master assembly drawing consists of the following: It shows the finished board with all permanently attached hardware. It contains the general notes and a parts list. See FIGURE 22-15.

22.11.3.3 Producing The Master Drawing. The master drawing may be prepared from a transparency of the master artwork drawing.

22.11.3.4 Hole Locations And Size. Hole locations not shown on the master artwork drawing are specified on the master drawing. Holes may be coded for size with a tabulation showing the size for each code letter. The diameter of an unsupported hole must not exceed the diameter of the lead to be inserted by more than .028 diameter unless the lead is crimped and soldered to the terminal area. The inside diameter of plated-through holes, after plating, must not exceed the lead diameter by more than .035. The diameter of holes for eyelets must not exceed the outside diameter of the eyelet by more than .010. There must be a separate hole for each lead, part terminal and end of wire jumper. The number of different size holes should be kept to the minimum consistent with the above. Hole information is normally specified on the conductor side of the board.

22.11.3.5 Reference Designations Identification Callout. When component reference designations are required, they are marked or etched on the component side of the board. If they are to be etched, they are shown on the master artwork drawing.

22.11.3.6 Workmanship Note Requirement. Whenever the drawings are to comply with ASME Y14.100, workmanship standards and detail requirements for the printed circuit or printed wiring board are specified in the notes on sheet 1. A note similar to the following is recommended: "COMPLETED BOARD TO BE PER MIL-PRF-31032A & SUPPLEMENT 1." Those drawings not required to meet ASME Y14.100 need not reference the workmanship standard note; however, it may be included at the discretion of the project engineer. Other notes generally required are: (1) a note referencing ASME Y14.100; (2) part number marking; (3) reference designation marking; (4) reference to the schematic diagram; and (5) a note stating that hole coding is not to appear on the finished board.



22.11.3.7 Grid Size Dimension Identification. The dimension of the grid size used for location is provided by showing a small section of grid work with horizontal and vertical spacing dimensions, or the grid spacing is specified in a general note. Overall board dimensions are shown on sheet 1. Other dimensions, as necessary, are shown.

22.11.3.8 Parts List Identification Of Circuit Board. The parts list shows the board as -2 and the -1 assembly consists of the -2 board and all permanently attached (not removable) hardware.

22.11.4 Tables And Drafting Practices For Etched Boards.

22.11.4.1 Master Artwork Horizontal And Vertical Dimension For Purpose Of Reproduction To Full Scale. In all cases, regardless of size and board complexity, where the drawings are to comply with ASME Y14.100M, two (2) dimensions will be required on the master artwork drawing for the purpose of reproduction to full scale. One (1) will be shown in the horizontal direction and one (1) in the vertical direction. Those drawings not required to meet ASME Y14.100 may have a minimum of one dimension on the master artwork drawing for the purpose of reproduction to full scale. This dimension may be in the horizontal or vertical position, whichever distance is greater. All boards, that are 6" X 6" or greater will have two reduction dimensions on master artwork drawing to assure accuracy regardless of ASME Y14.100. The reduction dimension is the full scale distance between the vertical or horizontal cross-hairs of the targets.

22.11.4.2 Conductive Pattern Application. All of the conductive pattern must be dense uniform black with smooth edges, applied with pressure sensitive tape.

22.11.4.3 Letters, Numerals And Characters Application. All letters, numerals, and characters must be dense uniform black with smooth edges, applied with ink, paste-on decals, or transfer decals.

22.11.4.4 Permanently Attached Terminals. When standoff terminals are permanently attached to the board, it is recommended that MIL-HDBK-454, Requirement 5, be invoked by a general note on the master drawing, sheet 1, to cover the requirements for part attachment. The same note should be invoked on electronic assembly drawings to cover the requirements for attaching electronic components to the board or to terminals.

22.11.4.5 Title For Master Drawing. The title for the master drawing should be Printed Wiring (or Circuit) Board, as applicable, followed by the noun which describes the function of the completed board, i.e., amplifier, multiplexer, etc. and any required modifiers.

22.11.4.6 Application Of Tape Practices. The application of tape and drafting practices utilized in the preparation of the master artwork drawing must conform with the requirements of MIL-PRF-31032A & Suppl. 1 and IPC-2221A and IPC-2222.

22.11.4.7 Tables Applicable To Printed Wiring (Or Circuit) Boards.

FEATURE	POSITIONAL TOLERANCE ZONE	
	INCH	METRIC
LOCATION OF ANY TARGET WITH RESPECT TO ANOTHER	Ø .005	Ø 0.13
TERMINAL AREAS WITH RESPECT TO GRIDS	Ø .010	Ø 0.25
MISMATCH TARGETS AND TERMINAL AREAS, SIDE 1 TO SIDE 2	Ø .005	Ø 0.13

MAXIMUM ALLOWABLE TOLERANCE, FULL SCALE,
FOR LOCATIONS ON MASTER ARTWORK
 TABLE 22-4



CHARACTERS AND LINES	MINIMUM	
	INCH	METRIC
LINES (OTHER THAN CIRCUIT)	.015 WIDE	0.38 WIDE
COMPONENT REFERENCE DESIGNATIONS	.062 HIGH	1.58 HIGH
BOARD AND ASSY IDENTIFICATION NUMBER	.125 HIGH	3.18 HIGH
TERMINAL NUMBERS & CONTACT DESIGNATIONS	.062 HIGH	1.58 HIGH

WIDTH OF LINES AND HEIGHT OF CHARACTERS, FULL SCALE
TABLE 22-5

22.12 LOGIC DIAGRAMS.

22.12.1 Logic Diagrams. These are engineering reference documents and are not used for fabrication. The logic diagram shows by means of logic symbols and supplementary notations the details of signal flow and control. See FIGURE 22-17.

22.12.1.1 Graphic Symbols Drafting Practices.

22.12.1.1.1 Symbols. Symbols shall comply with ANSI/ IEEE STD 91/91A (ANSI Y32.14).

22.12.1.1.2 Position Of Symbol. The position of a symbol on a drawing does not alter its meaning.

22.12.1.1.3 Symbol Size And Line Weight. A symbol may be drawn to any proportionate size or line thickness to suit reproduction and commensurate with drawing size.

22.13 DRAWING CALLOUT - GENERAL NOTES.

22.13.1 Use Of A General Note. A general note is used to establish application requirements that are not otherwise covered by an existing specification or other acceptable document, or when space will not permit entry of all necessary information.

22.13.2 Length Of General Note To Be Short. When requirements are established by a general note, the note is limited to concise statements, but should be grammatically correct, clear, complete, and unambiguous.

22.13.3 When General Note Is Considered To Become A Company Specification. If lengthy or complex data is required to provide adequate information that is not covered by an existing document, the responsible designer initiates action for the preparation of an appropriate company specification.

22.13.4 General Notes. The following notes illustrate the type of general note coverage intended to be included on the engineering drawing. They may be varied to suit individual requirements. See SECTION 9.

22.13.4.1 General Application Note.

- X. PERMISSIBLE TO USE (alternate part number and code identification number, when required) IN PLACE OF (parts list part number).

22.13.4.2 Electrical Notes.

- X. MARK PER _____ WITH .12 HIGH REFERENCE DESIGNATIONS LOCATED APPROXIMATELY AS SHOWN.



22.13.4.2 (Continued)

- X. MAKE SILK SCREEN USING REPRODUCIBLES PER MIL-PRF-5480 TYPE_____.
- X. THIS DRAWING TO BE USED IN CONJUNCTION WITH
 - WIRING DIAGRAM NO. _____
 - SCHEMATIC DIAGRAM NO. _____
 - ASSEMBLY DRAWING NO. _____
 - INTERCONNECTION DIAGRAM NO. _____
- X. SOLDER CONNECTIONS PER _____.
- X. WIRE NUMBER CODING PER _____.
- X. ELECTRICAL BONDING PER _____.
- X. WIRE COLOR CODING PER _____.
- X. CONNECTORS TO BE CLOSED DURING HANDLING AND STORAGE.
- X. REMOVE DUST CAP ONLY AS NECESSARY.
- X. DISSIMILAR METALS USED SHALL CONFORM TO THE REQUIREMENTS OF MIL-STD-889.

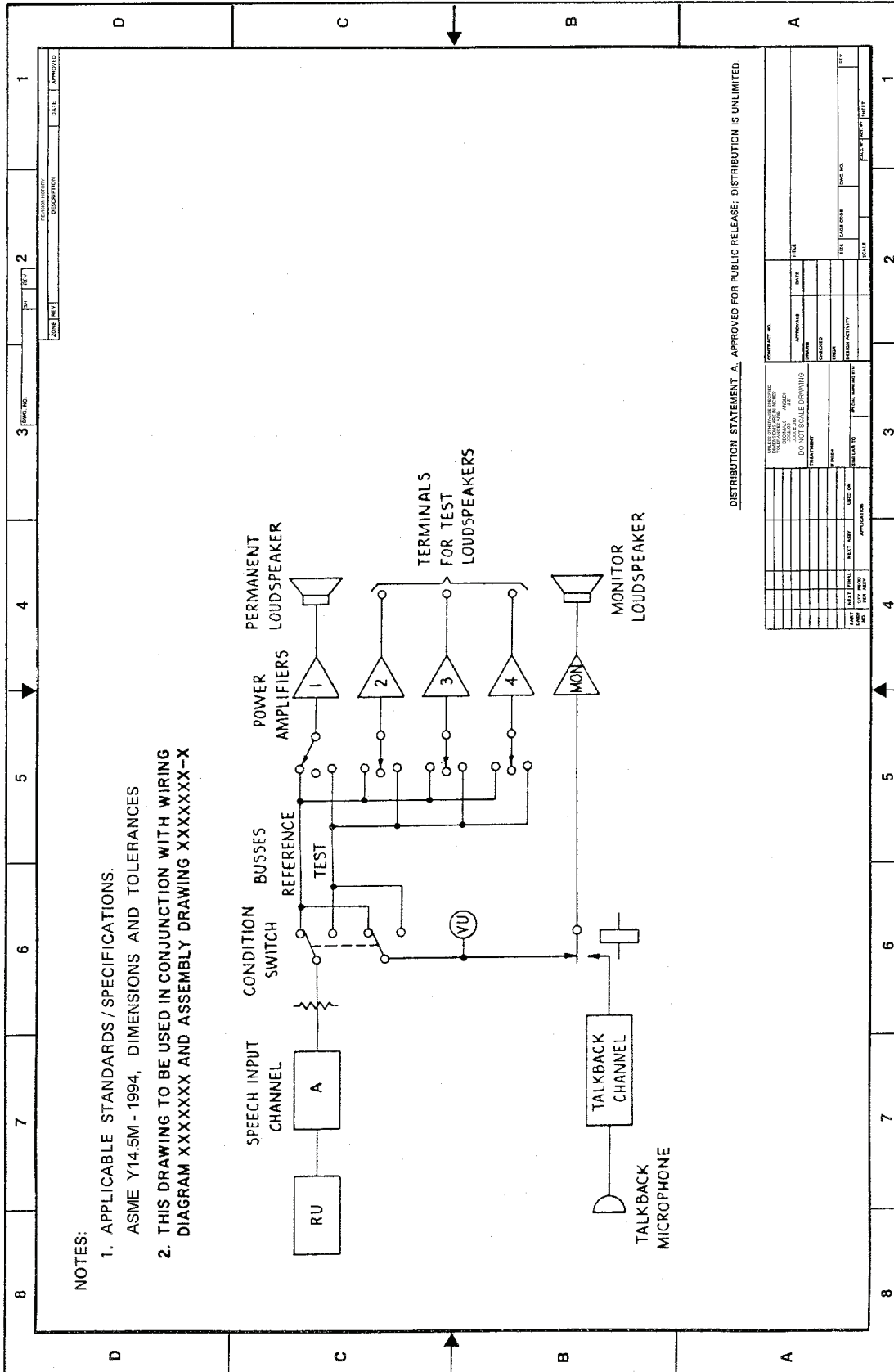

SINGLE LINE SCHEMATIC DIAGRAM
FIGURE 22-1

THIS SAMPLE DRAWING IS INFORMATIONAL ONLY AND COMPLETE TO THE DEGREE NECESSARY TO ILLUSTRATE THE TYPE OF DRAWING BEING DESCRIBED.

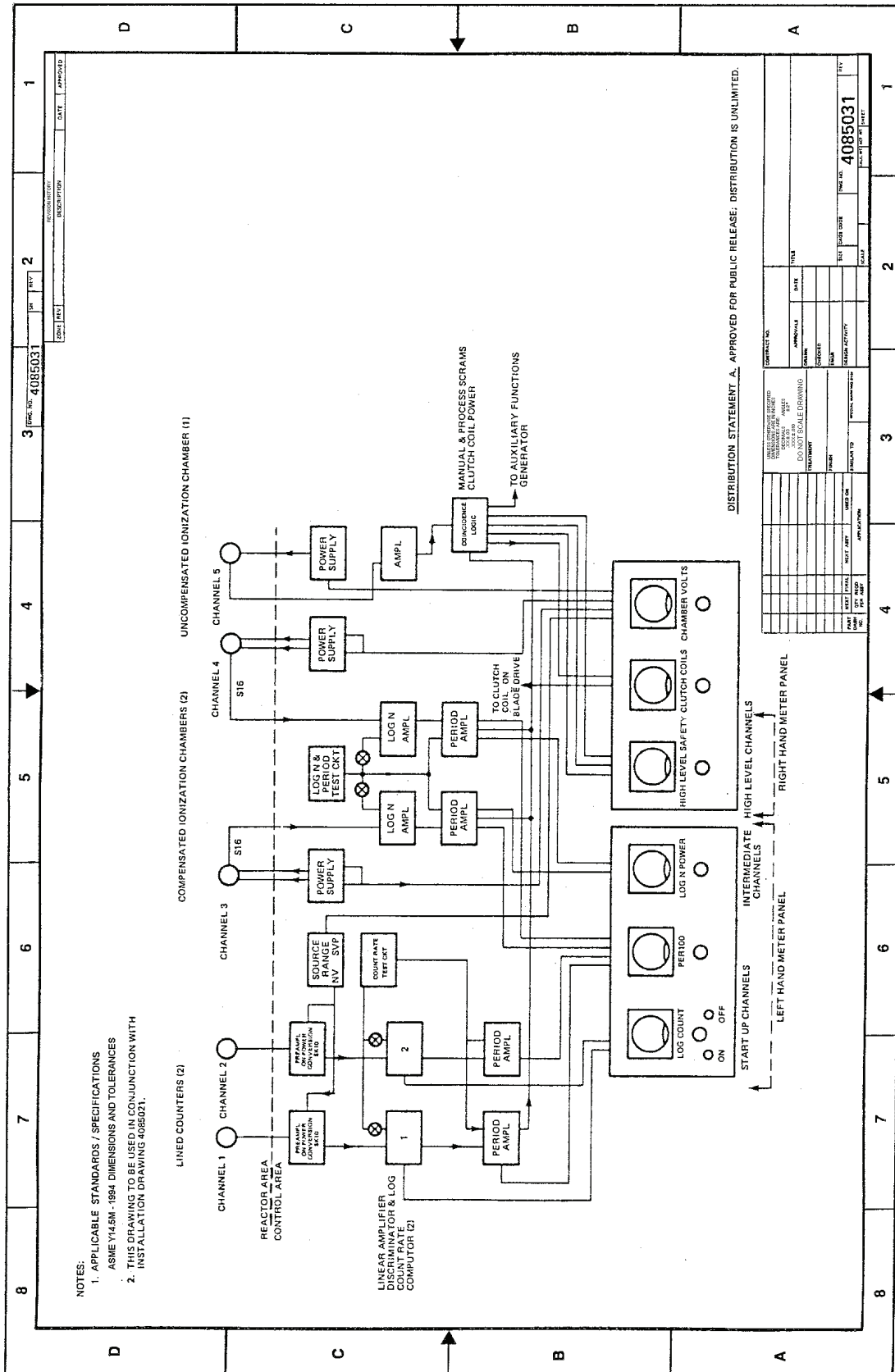

NOTES:
 1. APPLICABLE STANDARDS / SPECIFICATIONS
 ASME Y14.5M - 1994 DIMENSIONS AND TOLERANCES
 2. THIS DRAWING TO BE USED IN CONJUNCTION WITH
 INSTALLATION DRAWING 4085031.

DISTRIBUTION STATEMENT A. APPROVED FOR PUBLIC RELEASE; DISTRIBUTION IS UNLIMITED.

CONTRACT NO.	4085031
TITLE	SCALE DRAWING
DATE	
CHECKED	
DESIGN ACTIVITY	
REV. NO.	1
REV. DATE	
REV. BY	
REV. DATE	

THIS SAMPLE DRAWING IS INFORMATIONAL ONLY AND COMPLETE TO THE DEGREE NECESSARY TO ILLUSTRATE THE TYPE OF DRAWING BEING DESCRIBED.

BLOCK DIAGRAM
 FIGURE 22-2

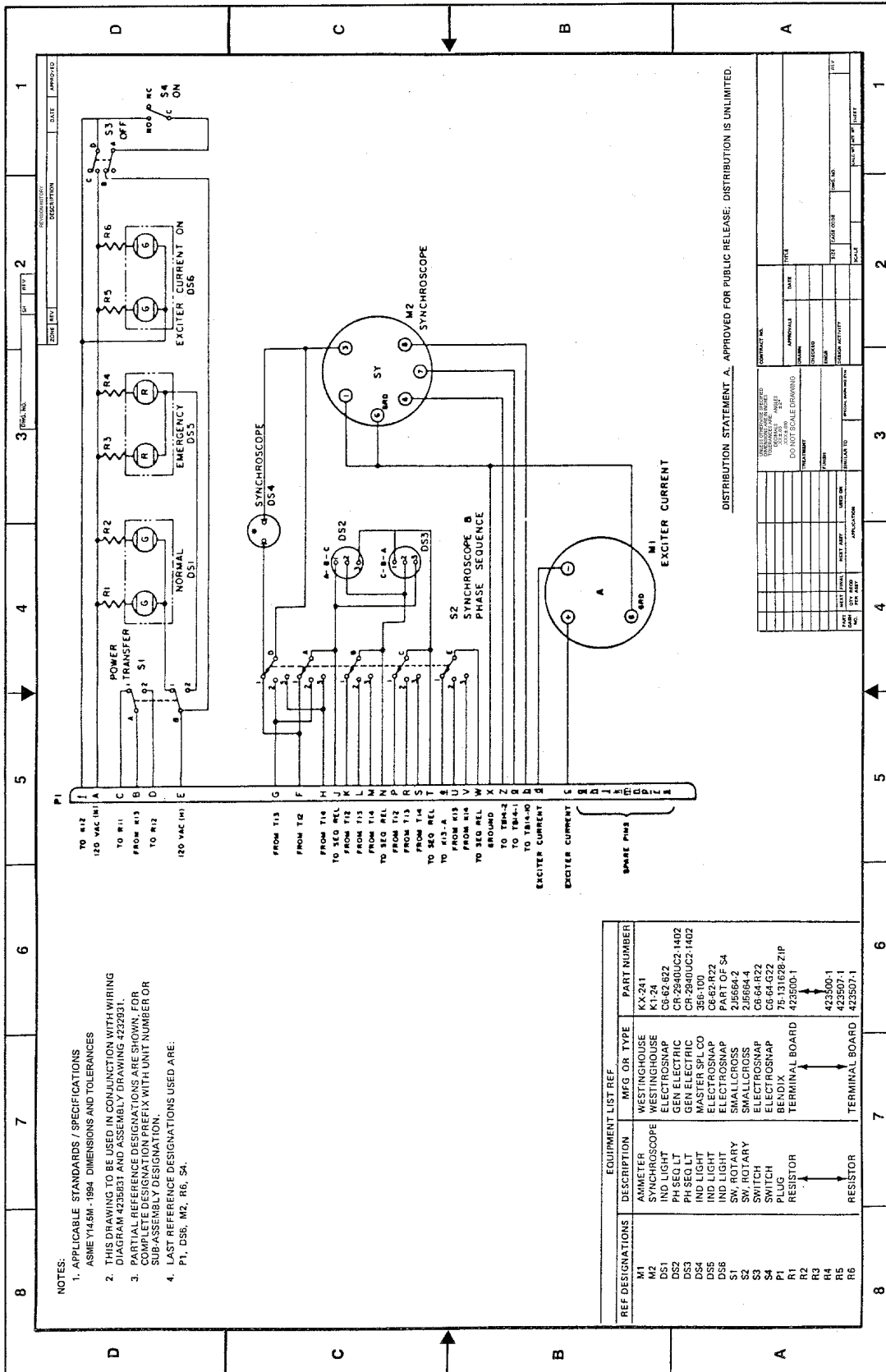

- NOTES:
1. APPLICABLE STANDARDS / SPECIFICATIONS
ASME Y14.5M - 1994 DIMENSIONS AND TOLERANCES
 2. THIS DRAWING TO BE USED IN CONJUNCTION WITH WIRING DIAGRAM 4225031 AND ASSEMBLY DRAWING 4225031.
 3. CAPITAL REFERENCE DESIGNATIONS ARE SHOWN FOR PARTS AND SUB-ASSEMBLY DESIGNATION.
 4. LAST REFERENCE DESIGNATIONS USED ARE:
P1, DS5, M2, R6, S4.

REF DESIGNATIONS	EQUIPMENT LIST REF.	DESCRIPTION	MFG OR TYPE	PART NUMBER
M1	AMMETER	WESTINGHOUSE	KX-241	
M2	SYNCHROSCOPE	WESTINGHOUSE	K1-24	
DS1	IND LIGHT	ELECTROSAP	CE-62-622	
DS2	PH SEQ LT	GEN ELECTRIC	CR-2940UC2-1402	
DS3	PH SEQ LT	GEN ELECTRIC	CR-2940UC2-1402	
DS4	IND LIGHT	MASTER SPLIC	356-100	
DS5	IND LIGHT	ELECTROSAP	CE-62-R22	
DS6	IND LIGHT	ELECTROSAP	216684-2	
S1	SW, ROTARY	SMALLCROSS	216684-4	
S2	SW, ROTARY	SMALLCROSS	216684-4	
S3	SWITCH	ELECTROSAP	CE-64-R22	
S4	SWITCH	ELECTROSAP	CE-64-G22	
P1	PLUG	75-131628-ZIP		
R1	RESISTOR	TERMINAL BOARD	422500-1	
R2	RESISTOR	TERMINAL BOARD	422500-1	
R3	RESISTOR	TERMINAL BOARD	422507-1	
R4	RESISTOR	TERMINAL BOARD	422507-1	
R5	RESISTOR	TERMINAL BOARD	422507-1	
R6	RESISTOR	TERMINAL BOARD	422507-1	

DISTRIBUTION STATEMENT A. APPROVED FOR PUBLIC RELEASE. DISTRIBUTION IS UNLIMITED.

CONTRACT NO.	DATE
PROJECT NO.	DATE
DESIGNED BY	DATE
CHECKED BY	DATE
APPROVED BY	DATE
TITLE	
SCALE	
DATE	
BY	
DATE	
BY	
DATE	
BY	
DATE	
BY	
DATE	

SCHMATIC DIAGRAM
FIGURE 22-3

THIS SAMPLE DRAWING IS INFORMATIONAL ONLY AND COMPLETE TO THE DEGREE NECESSARY TO ILLUSTRATE THE TYPE OF DRAWING BEING DESCRIBED.

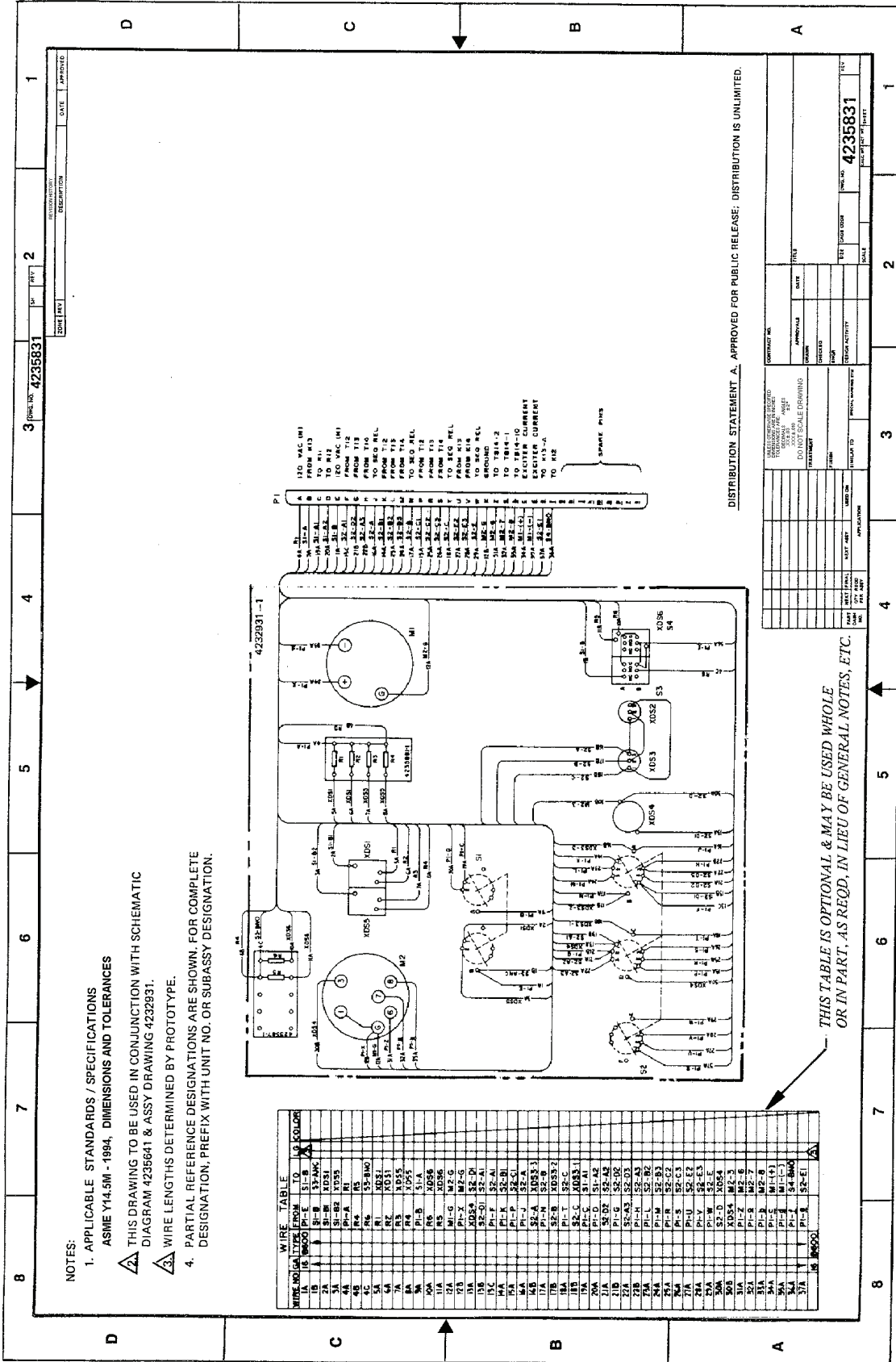

WIRING DIAGRAM-HIGHWAY TYPE
FIGURE 22-4

THIS SAMPLE DRAWING IS INFORMATIONAL ONLY AND COMPLETE TO THE DEGREE NECESSARY TO ILLUSTRATE THE TYPE OF DRAWING BEING DESCRIBED.

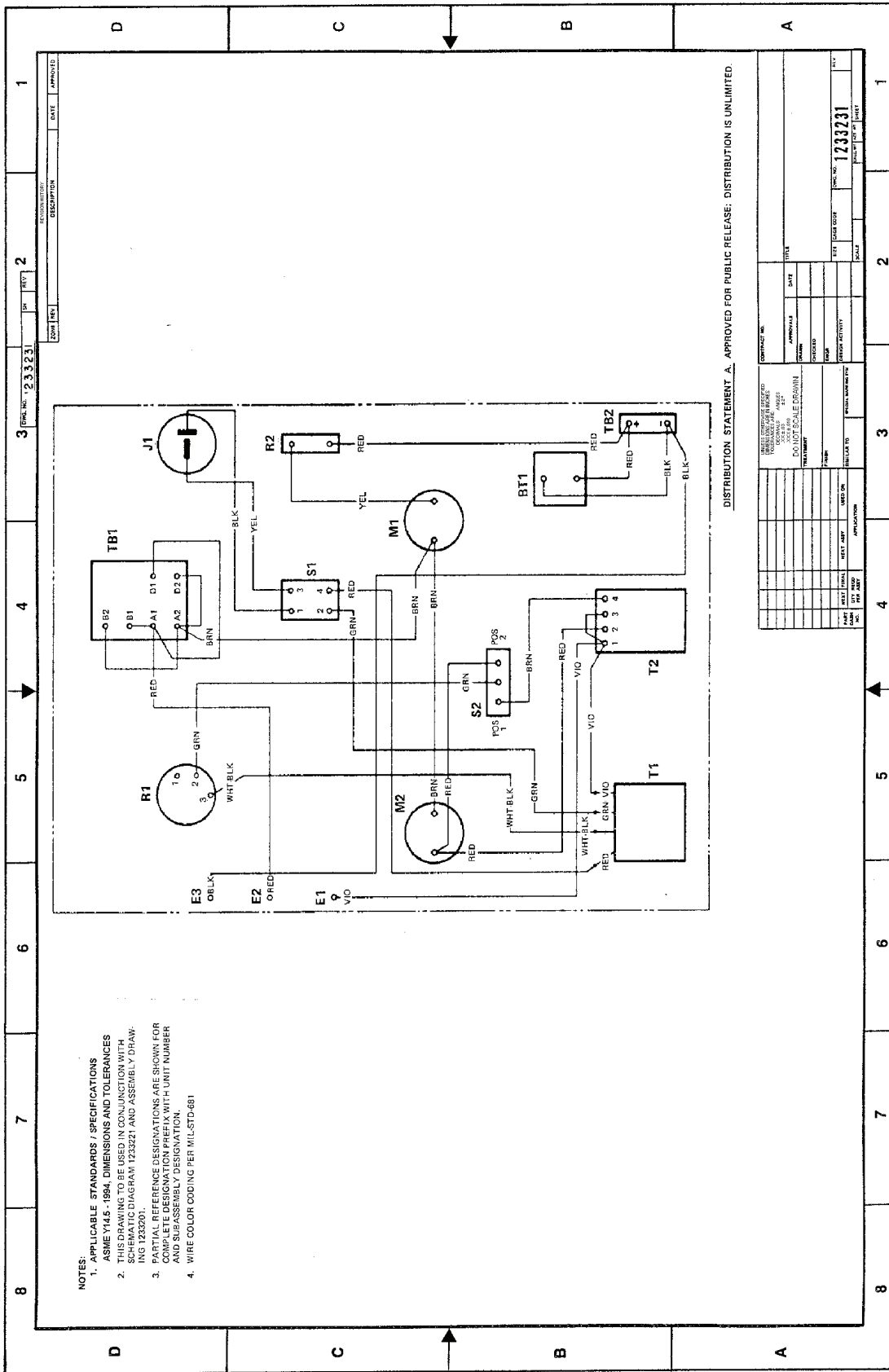

- NOTES:
1. APPLICABLE STANDARDS / SPECIFICATIONS
ASME Y14.5 - 1994, DIMENSIONS AND TOLERANCES
 2. THIS DRAWING TO BE USED IN CONJUNCTION WITH
DRAWING 1233221 AND ASSEMBLY DRAW-
ING 1233203.
 3. PARTIAL REFERENCE DESIGNATIONS ARE SHOWN FOR
COMPLETE DESIGNATION PREFIX WITH UNIT NUMBER
AND SUB-ASSEMBLY DESIGNATION.
 4. WIRE COLOR CODING PER MIL-STD-681

DISTRIBUTION STATEMENT A. APPROVED FOR PUBLIC RELEASE; DISTRIBUTION IS UNLIMITED.

DATE	DESCRIPTION	DATE	APPROVALS
233231			

DESIGNER	DATE	TITLE
DO NOT SCALE DRAWING		
CHECKED		
APPROVED		
DESIGN ACTIVITY		
SCALE		
FIG. NO.	1233231	
REV. NO.		
REV. DATE		
REV. BY		
REV. DATE		

THIS SAMPLE DRAWING IS INFORMATIONAL ONLY AND COMPLETE TO THE DEGREE NECESSARY TO ILLUSTRATE THE TYPE OF DRAWING BEING DESCRIBED.

WIRING DIAGRAM - POINT-TO-POINT
FIGURE 22-5

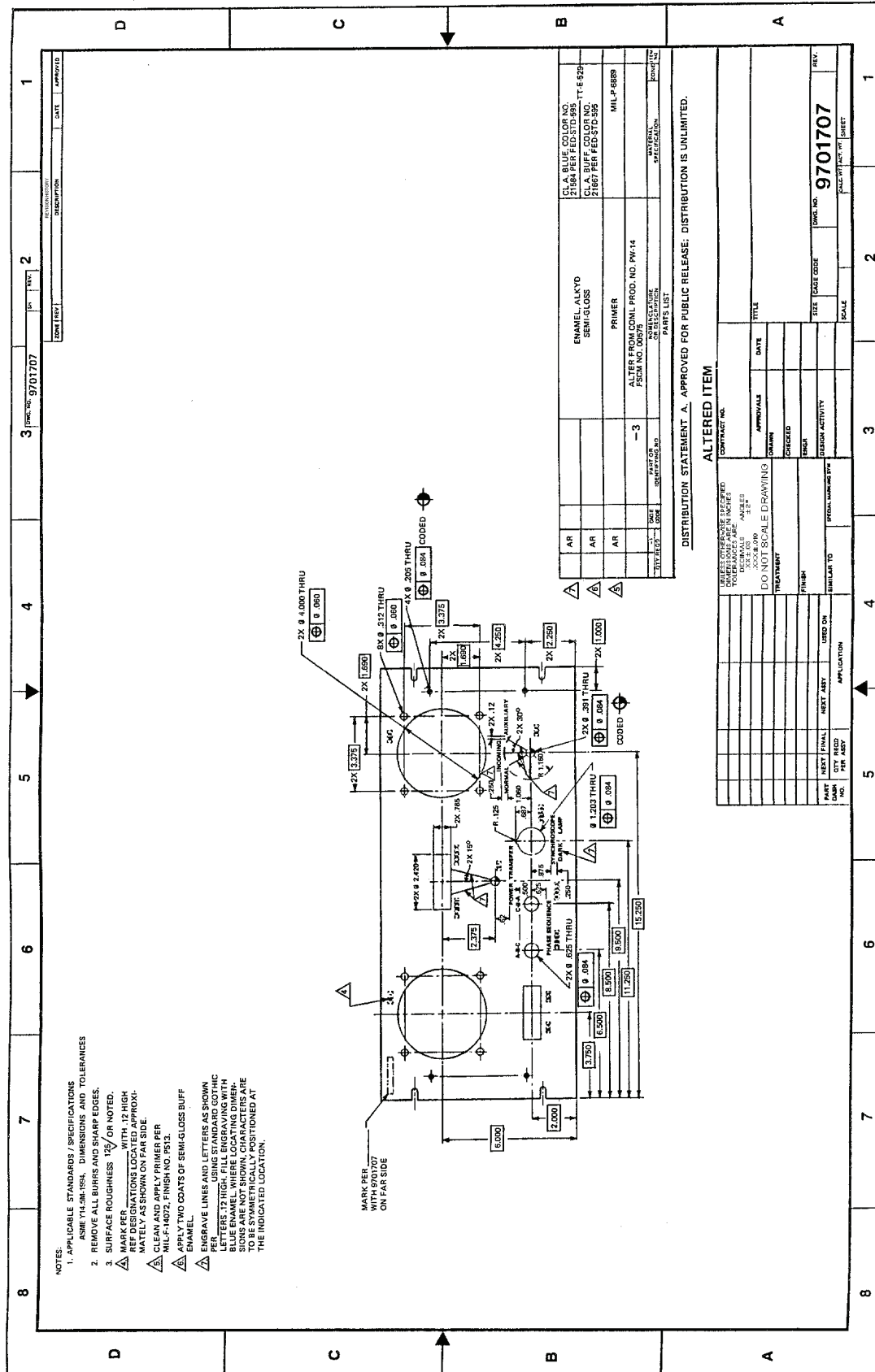

- NOTES:
1. APPLICABLE STANDARDS / SPECIFICATIONS
ASME Y14.5M-1994, DIMENSIONS AND TOLERANCES
 2. REMOVE ALL BURRS AND SHARP EDGES.
 3. SURFACE ROUGHNESS: 125/ OR NOTED.
- △ MARK PER 100 WITH 12 HIGH REF DESIGNATIONS LOCATED APPROXIMATELY AS SHOWN ON FAR SIDE.
 - △ CLEAN AND APPLY PRIMER PER MIL-P-18072, FINISH NO. 7513.
 - △ APPLY TWO COATS OF SEMI-GLOSS BUFF ENAMEL.
 - △ ENGRAVE LINES AND LETTERS AS SHOWN PER USING STANDARD GOTHIC LETTERS .12 HIGH. FILL ENGRAVING WITH BLUE ENAMEL WHERE LOCATING DIMENSIONS ARE SHOWN. DIMENSIONS ARE TO BE SYMMETRICALLY POSITIONED AT THE INDICATED LOCATION.

AR	CL.A. BLUE COLOR NO. 21584 PER FED. STD 895 TT-6 528
AR	CL.A. BUFF COLOR NO. 21587 PER FED. STD 895
AR	ENAMEL ALKYO SEMI-GLOSS
AR	PRIMER
-3	ALTER FROM COM. PROD. NO. PW-14 PSCM NO. 00075
PARTS LIST	
10774-02	1.004 084104000000
10774-03	1.004 084104000000

DISTRIBUTION STATEMENT A. APPROVED FOR PUBLIC RELEASE; DISTRIBUTION IS UNLIMITED.

ALTERED ITEM	
CONTRACT NO.	
UNLESS OTHERWISE SPECIFIED, DIMENSIONS ARE IN INCHES.	
DO NOT SCALE DRAWING	
TREATMENT	DATE
CHANGED	
USED ON	
APPROVALS	
DESIGN ACTIVITY	
FILE CASE CODE	9701707
SCALE	
DATE	
DESIGNER	
CHECKED	
DATE	
APPROVED	
DATE	
DESIGNED BY	
CHECKED BY	
DATE	
APPROVED BY	
DATE	

ELECTRONIC DETAIL DRAWING
FIGURE 22-7

THIS SAMPLE DRAWING IS INFORMATIONAL ONLY AND COMPLETE TO THE DEGREE NECESSARY TO ILLUSTRATE THE TYPE OF DRAWING BEING DESCRIBED.

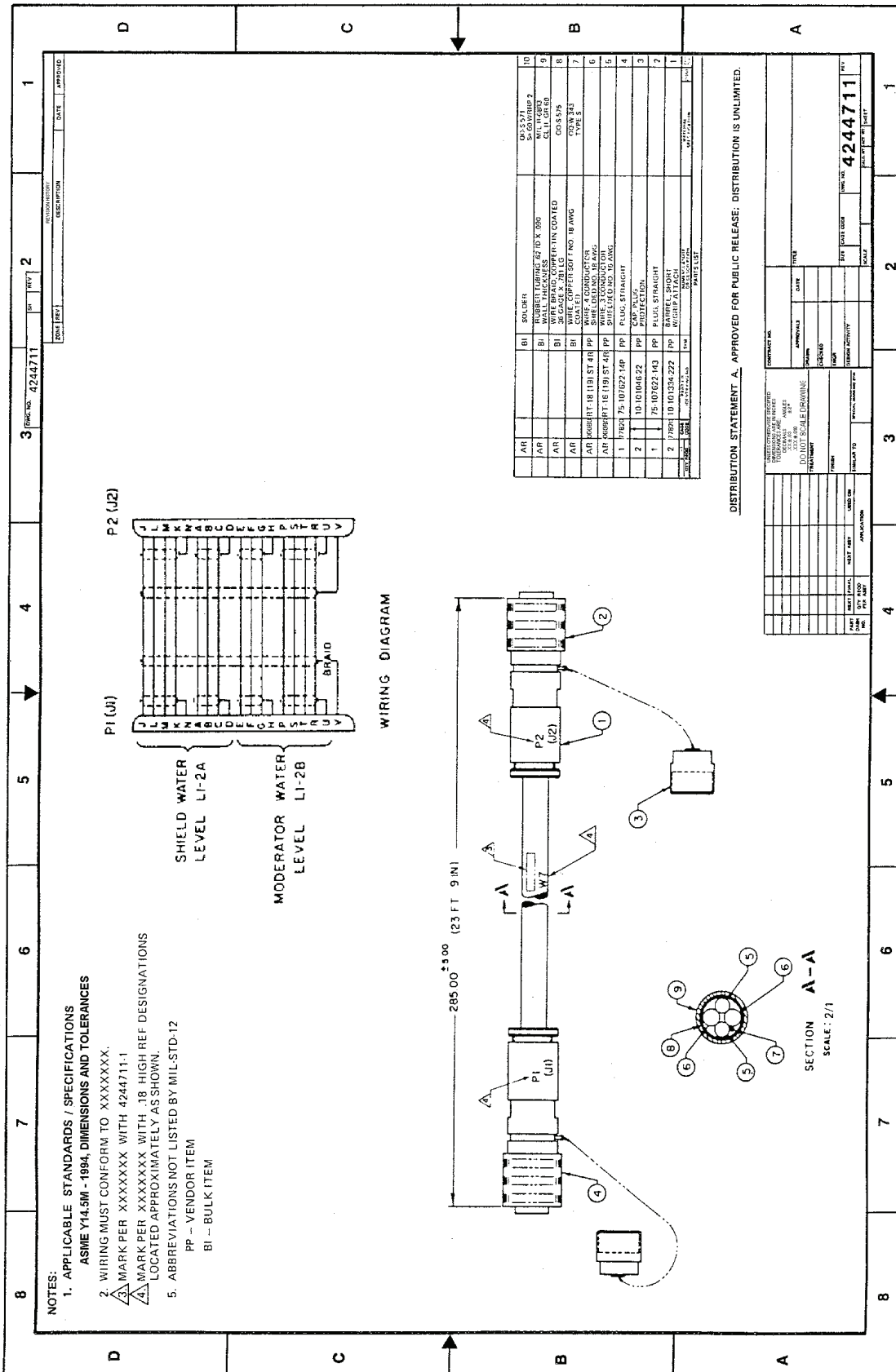

THIS SAMPLE DRAWING IS INFORMATIONAL ONLY AND COMPLETE TO THE DEGREE NECESSARY TO ILLUSTRATE THE TYPE OF DRAWING BEING DESCRIBED.

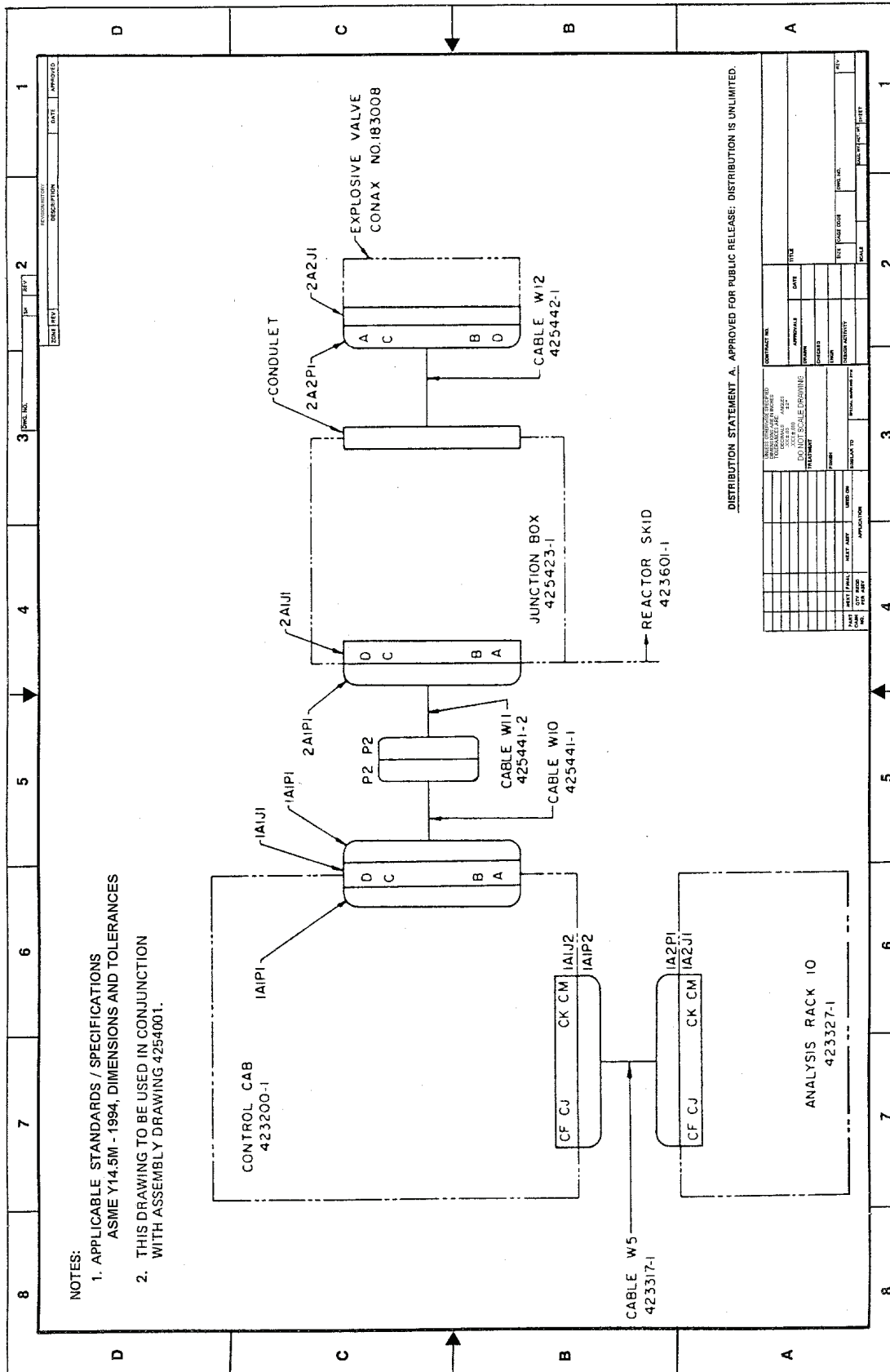

INTERCONNECTION DIAGRAM DRAWING
FIGURE 22-10

THIS SAMPLE DRAWING IS INFORMATIONAL ONLY AND COMPLETE TO THE DEGREE NECESSARY TO ILLUSTRATE THE TYPE OF DRAWING BEING DESCRIBED.

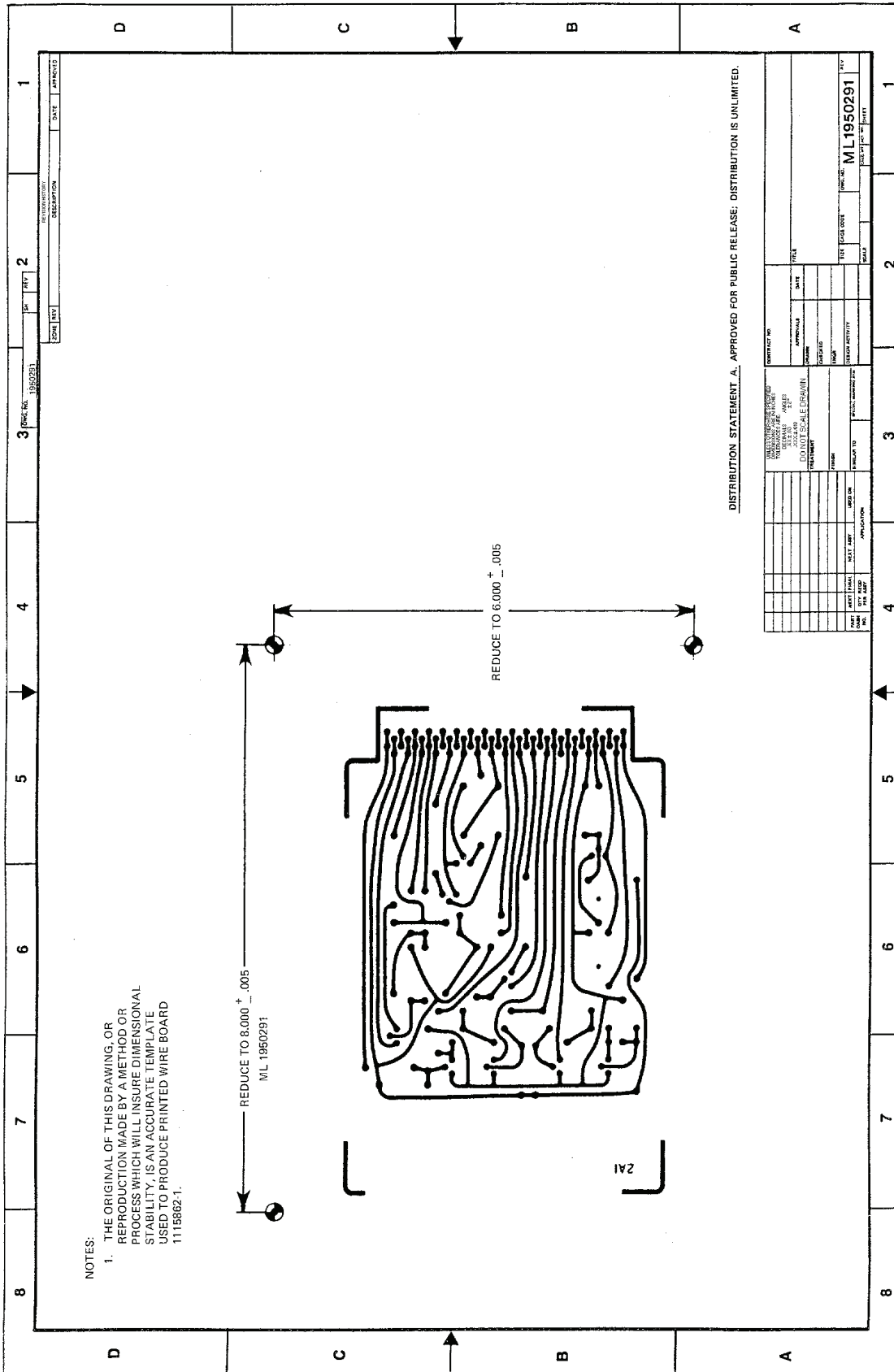

PRINTED BOARD ARTWORK MASTER (STABLE BASE ARTWORK)
FIGURE 22-11

THIS SAMPLE DRAWING IS INFORMATIONAL ONLY AND COMPLETE TO THE DEGREE NECESSARY TO ILLUSTRATE THE TYPE OF DRAWING BEING DESCRIBED.

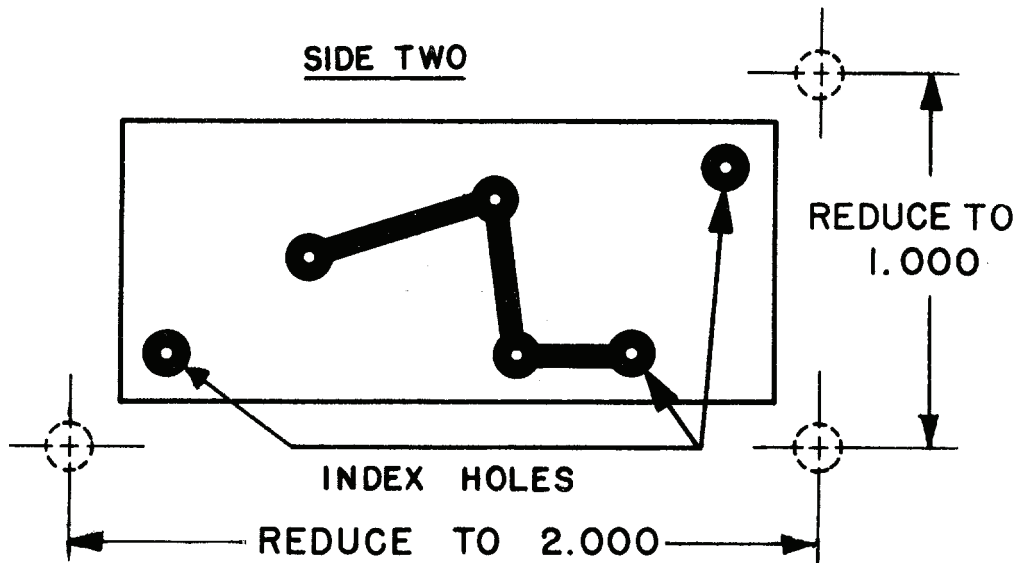
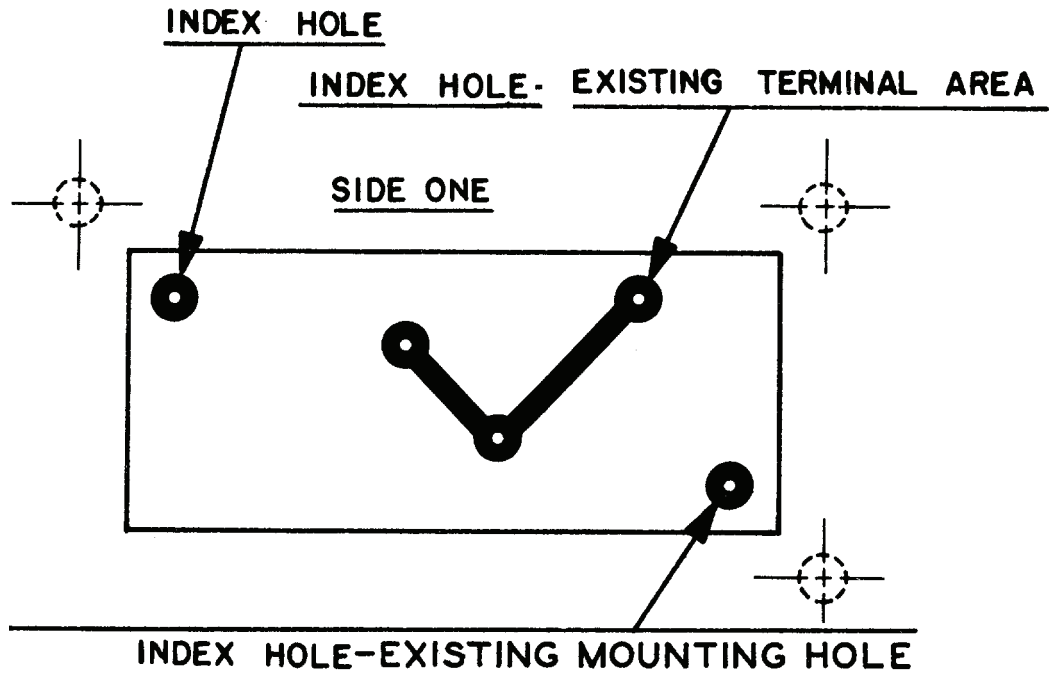

TWO-SIDED PRINTED WIRING BOARD, METHOD OF REGISTERING
USING INDEX HOLES WITHIN BOARD AREA
FIGURE 22-12

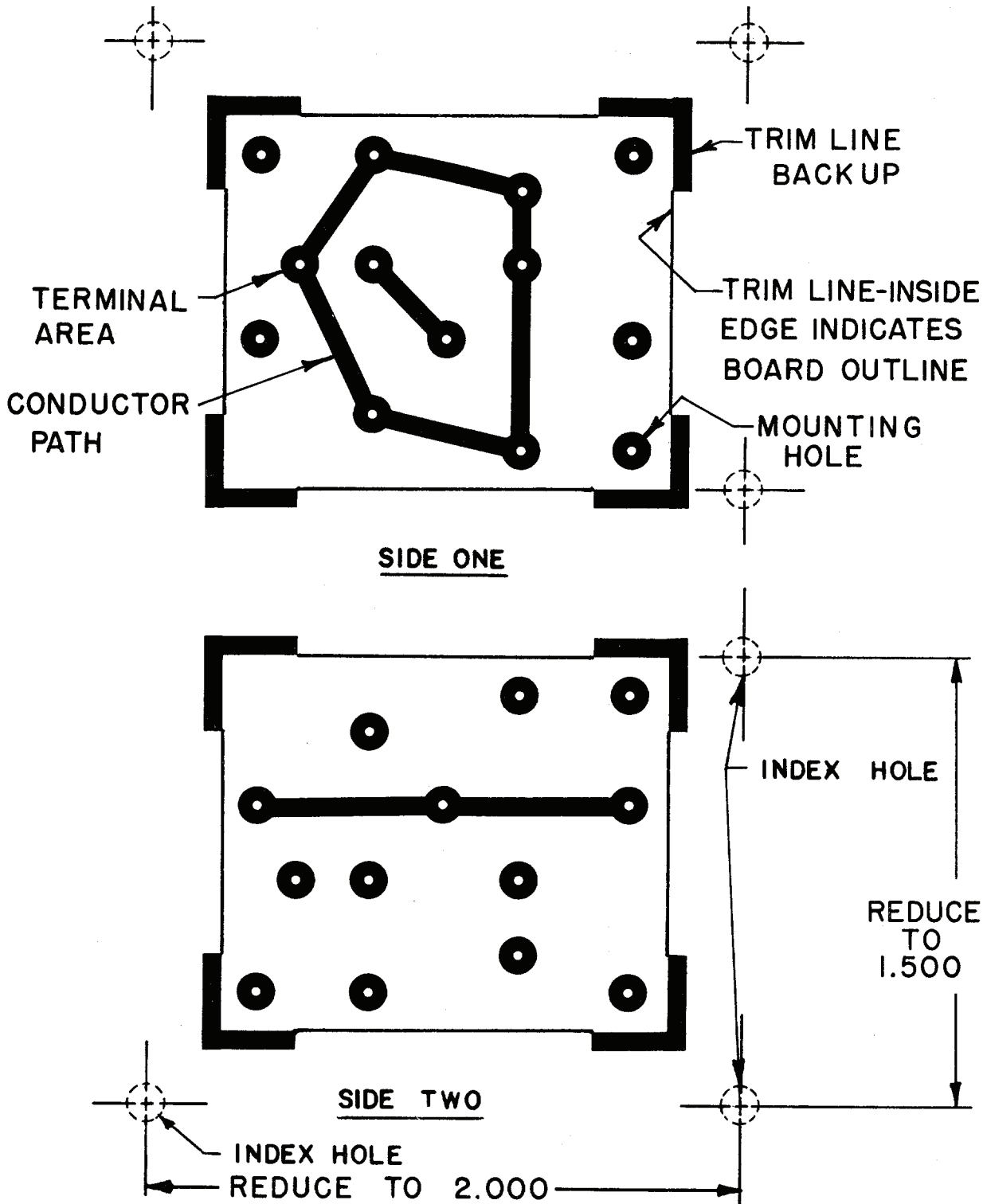

TWO-SIDED PRINTED WIRING BOARD METHOD OF REGISTERING
WITH INDEX HOLES OUTSIDE BOARD AREA
FIGURE 22-13

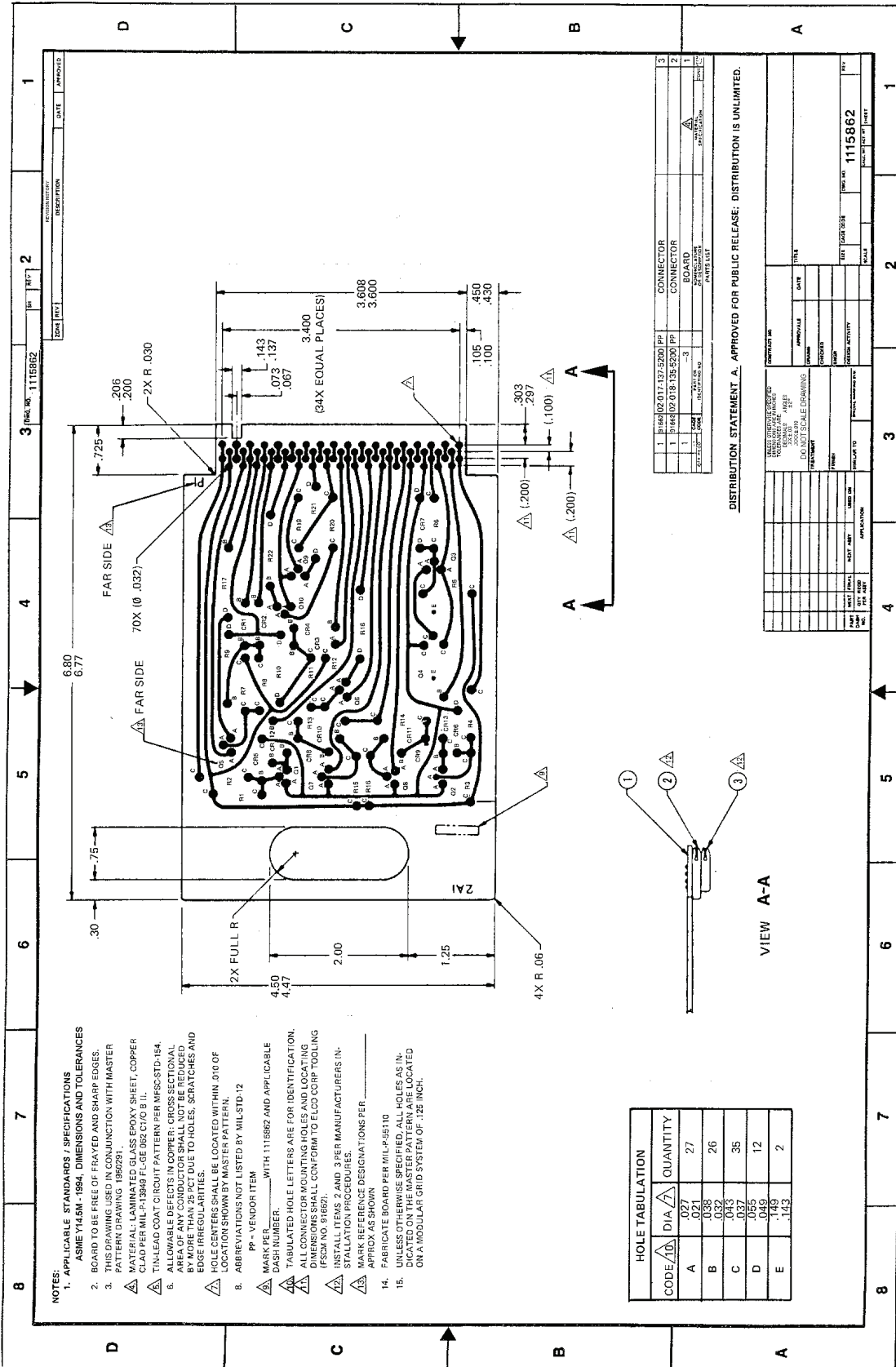





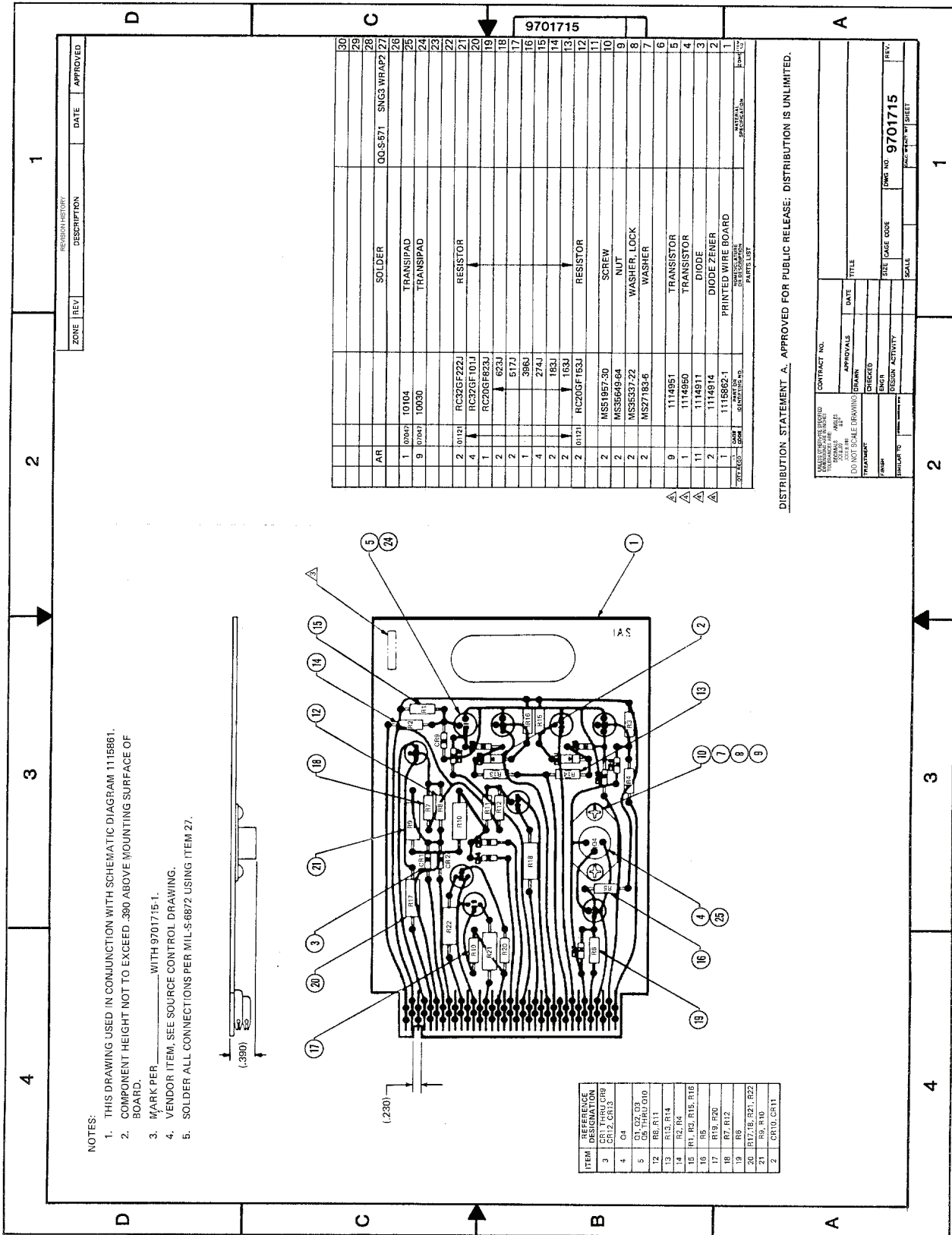







THIS SAMPLE DRAWING IS INFORMATIONAL ONLY AND COMPLETE TO THE DEGREE NECESSARY TO ILLUSTRATE THE TYPE OF DRAWING BEING DESCRIBED.

PRINTED BOARD DETAIL DRAWING
 FIGURE 22-14



PRINTED-BOARD (CIRCUIT BOARD) ASSEMBLY DRAWING
FIGURE 22-15

THIS SAMPLE DRAWING IS INFORMATIONAL ONLY AND COMPLETE TO THE DEGREE NECESSARY TO ILLUSTRATE THE TYPE OF DRAWING BEING DESCRIBED.

PREFERRED	NONPREFERRED
 <p>AREAS ON EACH SIDE OF DOTTED LINE SHOULD BE APPROXIMATELY EQUAL.</p> <p>THE RADIUS "R" SHOULD BE FROM TWO TO THREE TIMES THE HOLE DIAMETER.</p>	 <p>THE SOLDER FILLET WILL BE NON-SYMMETRICAL.</p>
 <p>APPROXIMATELY EQUAL</p> <p>THE DIMENSION "A" SHALL BE 1/3 TO 2/3 OF "R" (.040 MIN)</p>	 <p>SOLDER WILL FLOW AWAY FROM FILLET.</p>
 <p>UNIFORM CONDUCTOR PATTERN AROUND HOLE.</p>	 <p>SOLDER FILLET WILL BE NON-SYMMETRICAL.</p>
 <p>ALL SOLDER FILLETS WILL BE SYMMETRICAL.</p>	 <p>OUTSIDE SOLDER FILLETS WILL BE NON-SYMMETRICAL.</p>
 <p>ALL SOLDER FILLETS WILL BE GOOD.</p>	 <p>CONDUCTOR IN CENTER HOLE WILL PULL SOLDER FROM OUTSIDE CONDUCTORS.</p>
 <p>SOLDER WILL BLEED (FLOW) EVENLY.</p>	 <p>SOLDER WILL BLEED (FLOW) TOWARD LARGE HOLE.</p>

TERMINAL AREA PATTERNS FOR SOLDERED CONNECTIONS
FIGURE 22-16

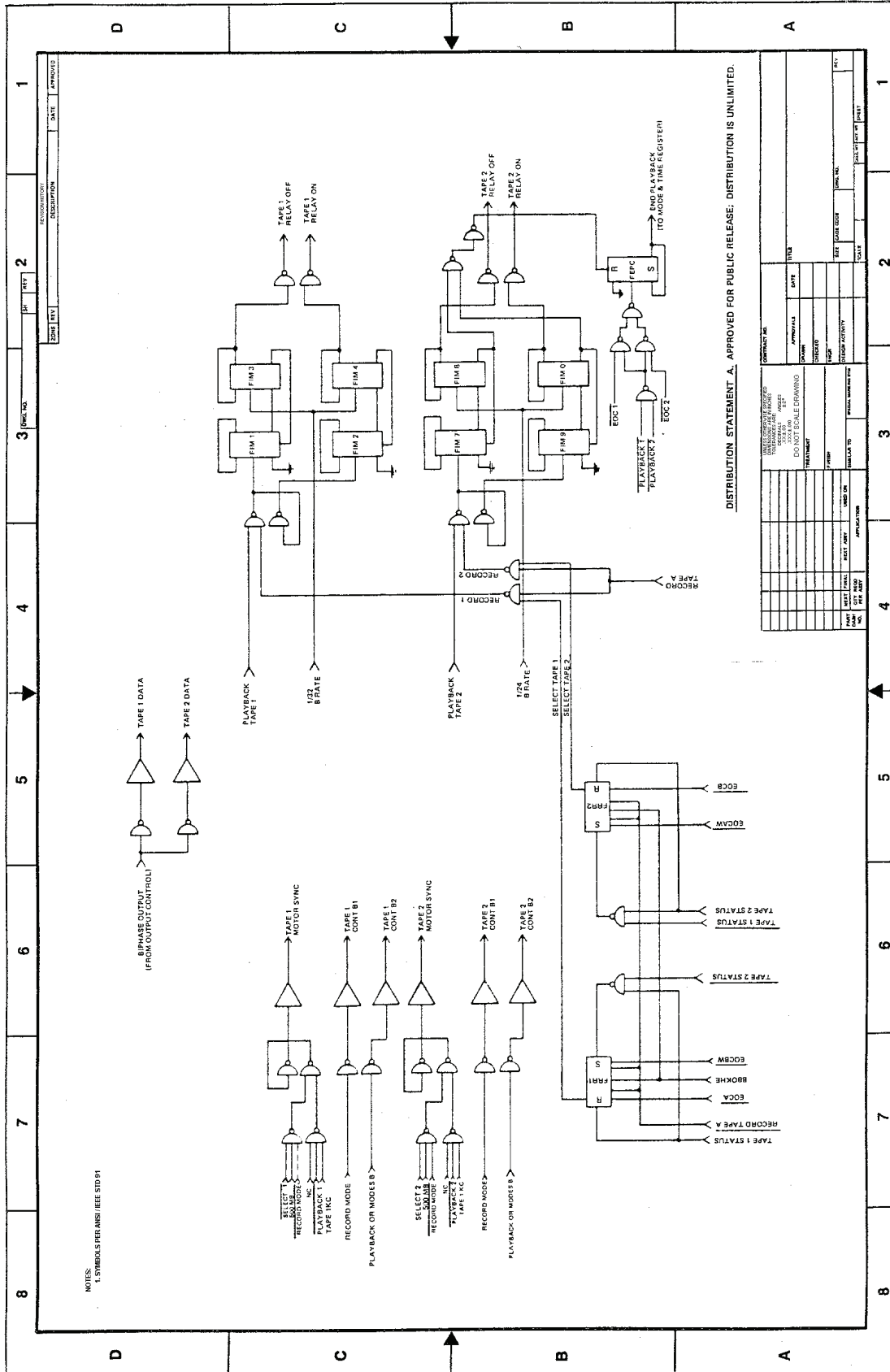

NOTES:
1. SYMBOLS PER ANSI IEEE STD 91

DISTRIBUTION STATEMENT A. APPROVED FOR PUBLIC RELEASE. DISTRIBUTION IS UNLIMITED.

THIS SAMPLE DRAWING IS INFORMATIONAL ONLY AND COMPLETE TO THE DEGREE NECESSARY TO ILLUSTRATE THE TYPE OF DRAWING BEING DESCRIBED.

BASIC LOGIC DIAGRAM
FIGURE 22-17



NOTES: