



21.1 SCOPE.

21.1.1 Purpose. This section establishes drafting and dimensioning practices pertinent to the preparation of drawings for parts to be fabricated from sheet metal. Additional information is presented to assist the draftsman in establishing proper dimensions for certain features of formed sheet metal parts.

21.2 APPLICABLE DOCUMENTS. **Note: DoD Policy Memo 05-3 “Elimination of Waivers to Cite Military Specifications and Standards in Solicitation and Contracts” has eliminated the need for waivers to use MIL-SPECS and MIL-STDS on DoD contracts. (See PREFACE 1, Section 2)**

ASME Y14.100	Engineering Drawing Practices
MIL-STD-403	Preparation for and Installation of Rivets and Screws, Rocket & Missile Structure (Inactive for New Design)
NAS 523	Fastener Code (Aerospace)
ASME Y14.5M	Dimensioning and Tolerancing for Engineering Drawings

21.3 DEFINITIONS. (Alphabetically Listed).

21.3.1 Bend Allowance. The length of the arc of the median line (neutral axis) of a bend between tangencies (from bend line to bend line). See FIGURES 21-1 and 21-2.

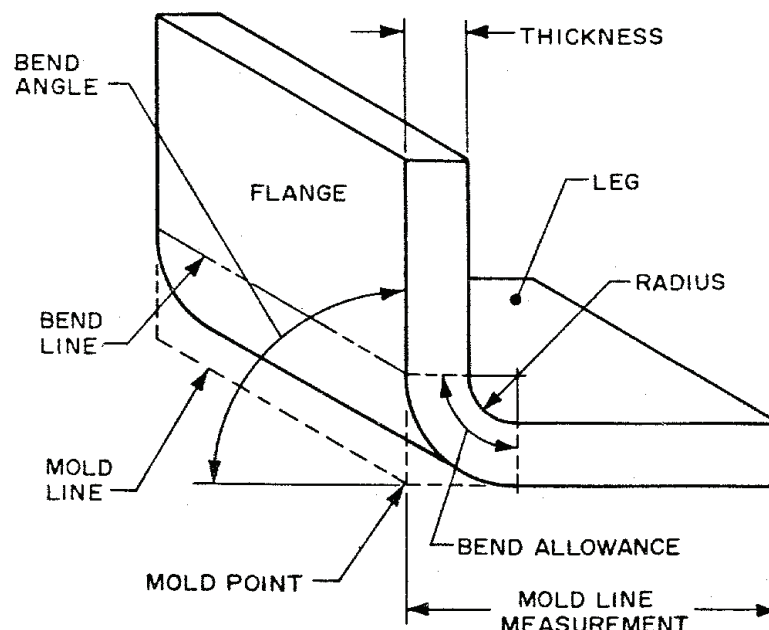

SHEET METAL TERMS
FIGURE 21-1



21.3.2 Bend Angle. The angle through which sheet metal is bent. It is measured from the flat through the bend to the finished angle after bending and is not to be confused with the included angle between the flange and adjacent leg. See FIGURE 21-2

21.3.3 Bend Line. The line of tangency where a bend changes to a flat surface or to a tangential bend with a different specified radius. There are two bend lines for each bend. See FIGURE 21-1.

21.3.4 Bend Radius. The radial value of a bend in sheet metal or similar material. The minimum bend radius is the smallest radius value that may be used to bend the material without cracking or requiring additional work when forming the flanges. See FIGURE 21-1 through 21-4.

21.3.5 Bend Relief. For optimum forming, interfering material at flange extremities is removed to a point behind the bend line to prevent cracking of the material when forming the flanges. See FIGURE 21-6 thru 21-8.

21.3.6 Bevel, Closed. The condition of a flange bent more than 90° from its flat condition. See FIGURE 21-2.

21.3.7 Bevel, Open. The condition of a flange bent less than 90° from its flat condition.

21.3.8 Blank. A flat sheet metal shape of approximately the correct size to make a finished part. The part is usually trimmed to size after forming.

21.3.9 Center Line Of Bend. A radial line from the center of the bend radius which bisects the included angle between bend lines. See FIGURE 21-3.

21.3.10 Developed Length. The length of a flat part or material which can be bent to make the part depicted on a drawing. This length is always shorter than the sum of mold line dimensions on the part. See FIGURE 21-5.

21.3.11 Dimpling. Stretching a relatively small shallow indentation into sheet metal. Stretching metal into a conical flange for use of a countersunk rivet head or screw. Dimpling is stronger than countersinking and should be performed on thin panels.

21.3.12 Flat Pattern. A flat layout of a formed sheet metal part which can be bent to make the finished part without trimming after forming.

21.3.13 Form Block Line. The inside mold line of a part.

21.3.14 Joggle. An offset in the face of a part which has an adjacent flange. See FIGURE 21-9 and 21-10.

21.3.15 Mold Line. The line of intersection of two flat surfaces of a formed sheet metal part. The term alone usually refers to the outside mold line. See form block line also. See FIGURE 21-1.

21.3.16 Median Line (Neutral Axis.) In bent material, the median line (neutral axis) is a line of zero stress within the bend, thus it is not subjected to tension (stretched) or subjected to compression (compressed). All material to the outside of the median line is in tension, and all material to the inside of the median line is in compression. The median line is located approximately 44% of the material thickness from the inside surface of the bend. See FIGURE 21-2.



21.3.17 Set Back. The amount of deduction in length when a flat pattern is developed across a bend. It represents the saving in material by going around a bend radius rather than around a square corner.

21.3.18 Tool Holes Or Pin Holes. Holes without a functional purpose in the end product. Used for aligning a part in the proper position on a die or form block, or for other fabrication or tooling purposes.

21.4 GENERAL.

21.4.1 Fabrication Of Sheet Metal Parts. The fabrication of sheet metal parts involves methods which are quite different from those used for fabricating machined parts, and it is necessary that the draftsman understand these differences in order to properly prepare drawings. Sheet metal parts are frequently cut out of flat stock using developed patterns (templates) or CNC programs and then formed to finished parts. Other parts may be made from flat blanks and deep drawn or formed into complex contours by dies in a punch press or hydropress, or by drop hammer dies. These parts are usually trimmed after forming to produce the finished part. These are only some of the methods which force the establishment of certain special procedures for sheet metal drawings.

21.5 CHARACTERISTICS OF SHEET METAL BENDS.

21.5.1 Location Of Median Line (Neutral Axis) For Bend Allowance Calculations. When metal is bent, there is usually a local thinning or thickening of the material. This happens because the material is compressed on the inside of the bend and stretched on the outside, causing some displacement and plastic deformation of the material. It has been determined that there is a line through the bend where no stretching or compression takes place. This line, called the median line (neutral axis), is located approximately 44% of the material thickness from the inside surface of the bend. The location of the median line (neutral axis) forms the basis for bend allowance calculations. See PARAGRAPH 21.3.16 and FIGURE 21-2.

21.5.2 Bend Formulas. The following paragraphs should aid in the preparation of flat pattern development for undimensioned drawings and provide information for calculating dimensions for developing flat blanks. Flat development of sheet metal parts is not permitted on engineering drawings except undimensioned drawings.



21.5.2.1 Bend Allowance. The following empirical formula has been developed to determine the distance around a bend for all bends one inch or less: $(.0078T + .0174R)$ times the number of degrees of bend where $T =$ material thickness and $R =$ inside bend radius. See FIGURE 21-2a, b and c.

BEND ALLOWANCE FORMULA PER DEGREE OF BEND.
 $(.0078T + .0174R) \times (\text{No. OF DEGREES})$

WHERE: $R = .25$
 $T = .125$
BEND ANGLE = No. OF DEGREES

BEND ALLOWANCE FOR 90°

$(.0078T + .0174R) \times \text{No. OF DEGREES} =$
 $[(.0078)(.125) + (.0174)(.25)] \times 90 =$
 $(.000975 + .00435) \times 90 =$
 $.005325 \times 90 = .479$

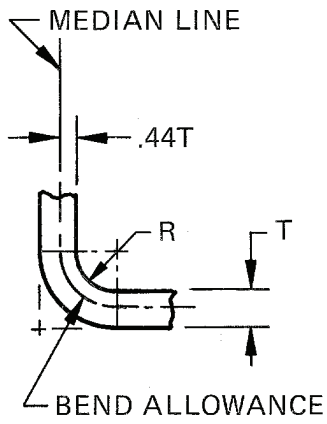

INCH	METRIC
.005325	0.13526
.0078	0.198
.0174	0.442
.125	3.18
.25	6.4
.320	8.13
.479	12.17
.799	20.29

RIGHT ANGLE **a.**

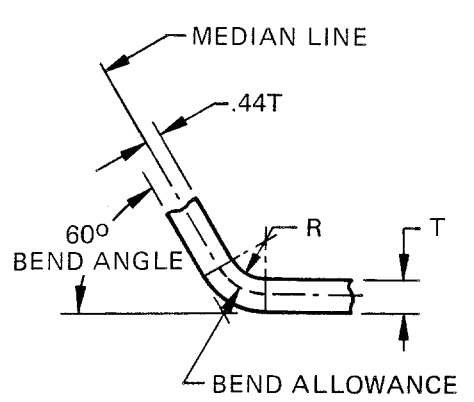

BEND ALLOWANCE FOR 60°
 (FROM PREVIOUS CALCULATION)
 $.005325 \times 60 = .320$

OPEN ANGLE **b.**

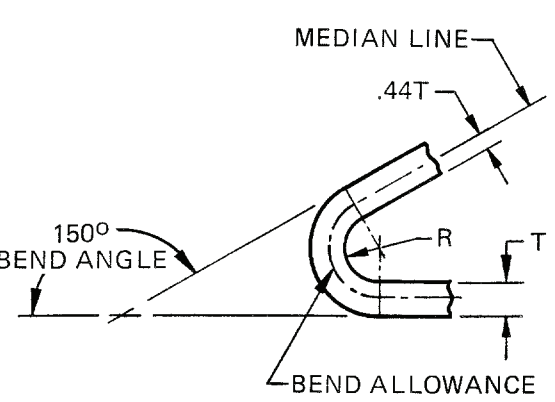

BEND ALLOWANCE FOR 150°
 (FROM PREVIOUS CALCULATION)
 $.005325 \times 150 = .799$

CLOSED ANGLE **c.**

BEND ALLOWANCE
FIGURE 21-2

21.5.2.2 Distance From Bend Line To Mold Line. This distance can be calculated by trigonometry using the following formulas: (See FIGURE 21-3).

$D = (R + T) \times \tan \frac{a}{2}$ Or $D = \frac{(R + T)}{\cot \frac{a}{2}}$ WHERE:
 D = DISTANCE FROM BEND LINE TO MOLD LINE
 R = INSIDE BEND RADIUS
 T = MATERIAL THICKNESS
 a = ANGLE IN DEGREES

EXAMPLE
 WHERE: R = .25
 T = .125
 a = 150°

$D = (R + T) \times \left(\tan \frac{a}{2} \right)$
 $D = (.25 + .125 \times \tan \frac{150^\circ}{2})$
 $D = .375 \times \tan 75^\circ$
 $D = .375 \times 3.732$
 $D = 1.400$

INCH	METRIC
.125	3.18
.25	6.4
.3732	9.479
.375	9.52
1.400	35.56

NOTE:
 FOR 90° FLANGES, D = R + T
 SINCE THE TANGENT OF 45° = 1

BEND LINE- MOLD LINE CALCULATION
 FIGURE 21-3

21.5.2.3 Set Back (Applicable To Closed Angles Only). This is the deduction made in the length of a flat pattern development corresponding to the amount of material saved by bending around a radius instead of a sharp corner. It is equal to twice the distance from the bend line to the mold line minus the bend allowance. The formula is written as follows:

$$K = 2D -- BA$$

WHERE: K = SET BACK
 D = DISTANCE FROM BEND LINE TO MOLD LINE
 BA = BEND ALLOWANCE

EXAMPLE:

Using the preceding examples, the "D" distance was calculated to be 1.400 and the bend allowance was .799; therefore:

$$K = 2D -- BA$$

$$K = 2(1.400) -- .799$$

$$K = 2.800 -- .799$$

$$K = 2.001$$

21.5.2.4 Dimensioning The Part. Using the bends in the previous examples; the part is dimensioned as in FIGURE 21-4.

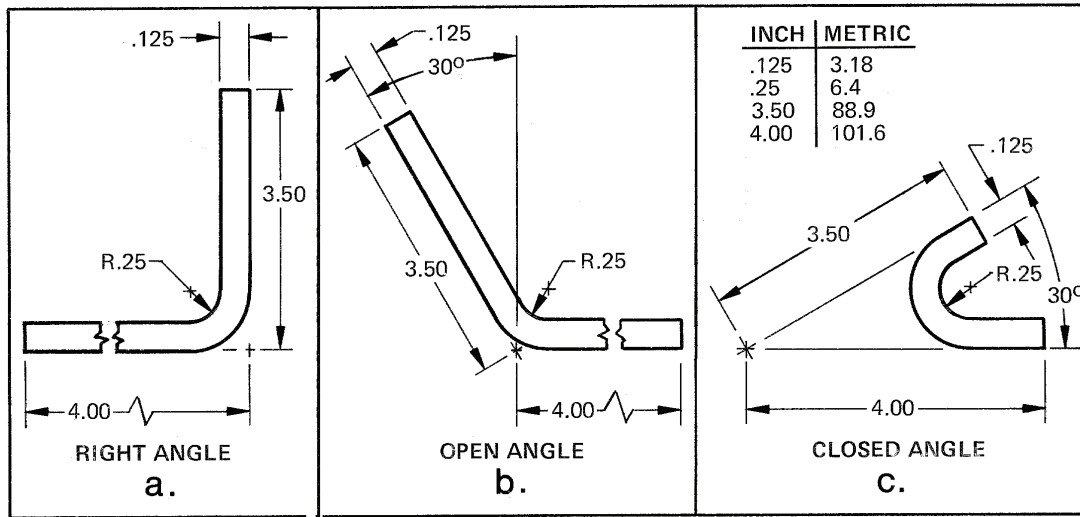

BEND DIMENSIONING

FIGURE 21-4

21.5.2.5 Developing A Flat Pattern. The flat pattern for each of the previous examples is developed as shown in FIGURE 21-5.

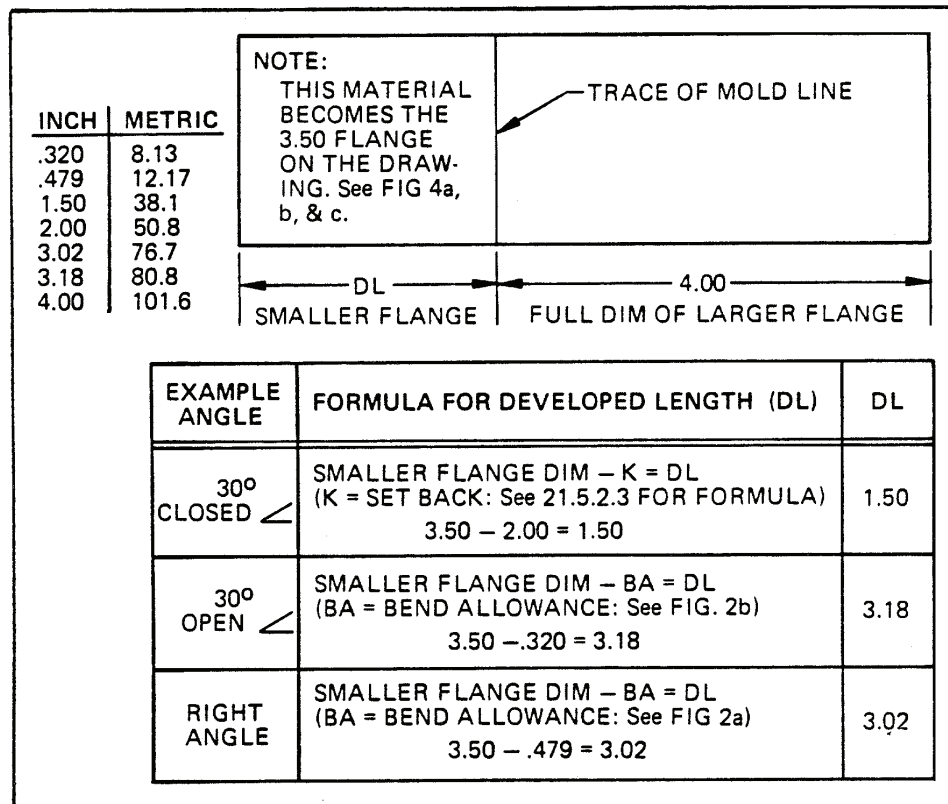

FLAT PATTERN DEVELOPMENT

FIGURE 21-5

21.6 BEND RELIEF.

21.6.1 Bend Relief Cutouts. Whenever sheet metal bends intersect one another, it is necessary to remove material from the intersection area to prevent interference and buckling. Material must be removed at least .03 behind the intersection of bend lines. See FIGURE 21-6. There are many possible configurations for bend reliefs, two of which are illustrated in FIGURE 21-6. The usual practice is to radius the inside of a relief cutout, but this is not essential for the function of a relief cutout. A sharp corner will do as well if it removes material .03 beyond the intersection of bend lines.

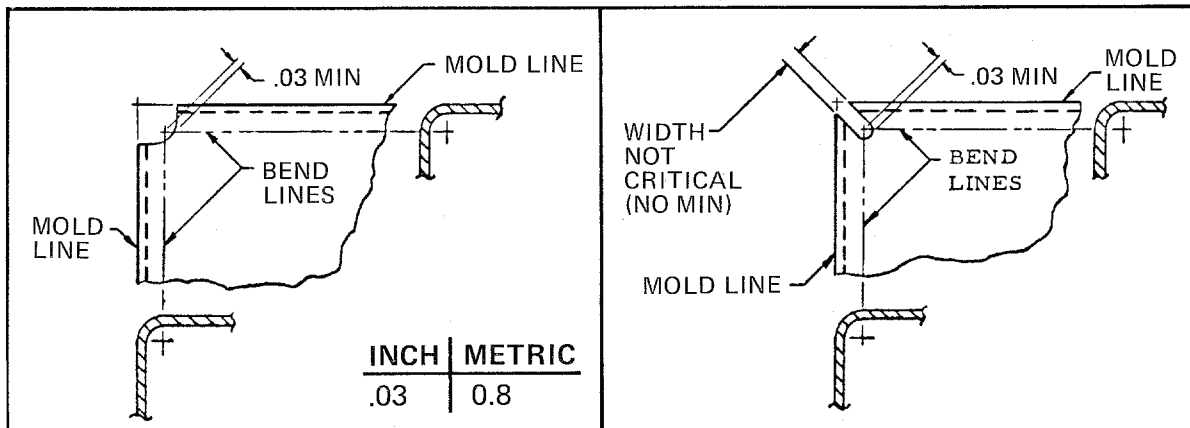

BEND RELIEF CUTOUTS

FIGURE 21-6

21.6.2 Relief Cutout Dimensioning. The distance from the mold line to the bend line can be calculated by using the formula in PARAGRAPH 21.5.2.2. This distance can be used in various ways to establish dimensions for the relief cutout, depending on the shape of the cutout. Two examples are shown in FIGURE 21-7 and 21-8 to illustrate the possibilities.

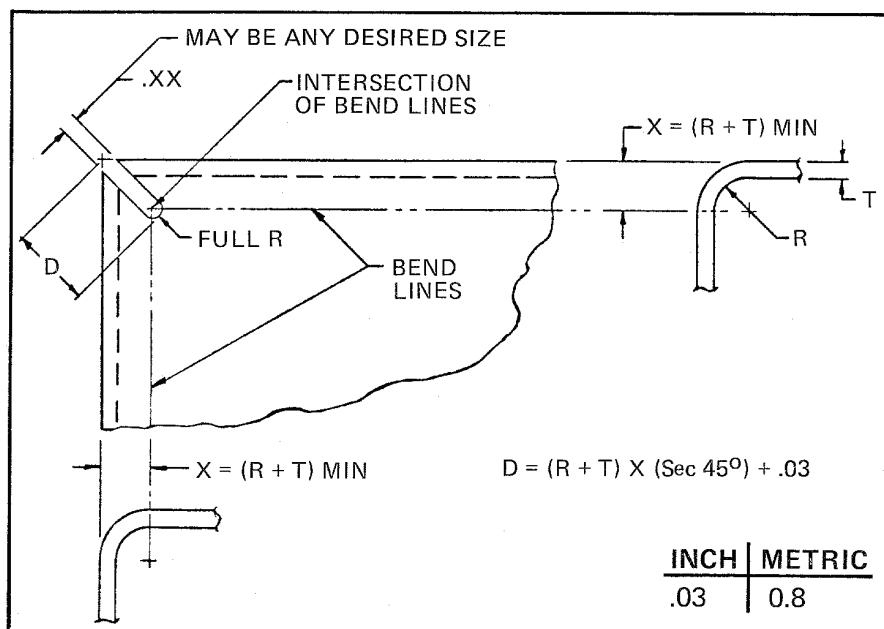

BOTH FLANGES BENT 90° WITH 90° CORNER

FIGURE 21-7

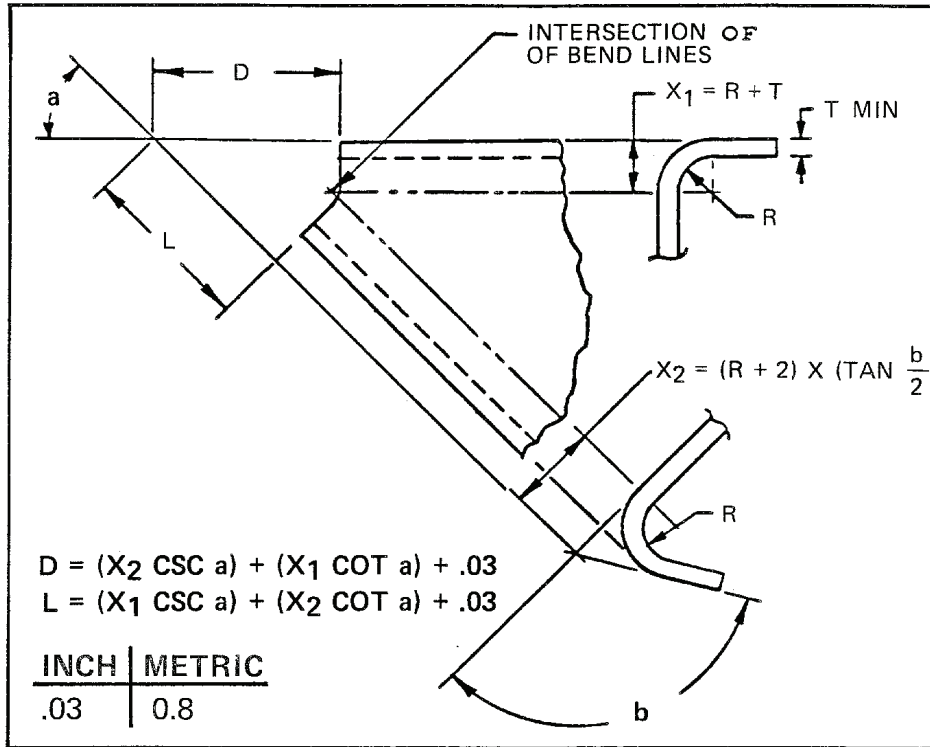

FLANGES BENT AT DIFFERENT ANGLES WITH CORNER OTHER THAN 90°

FIGURE 21-8

21.7 JOGGLES.

21.7.1 Joggle Dimensioning. Joggles are shown and dimensioned as shown in FIG. 21-9.

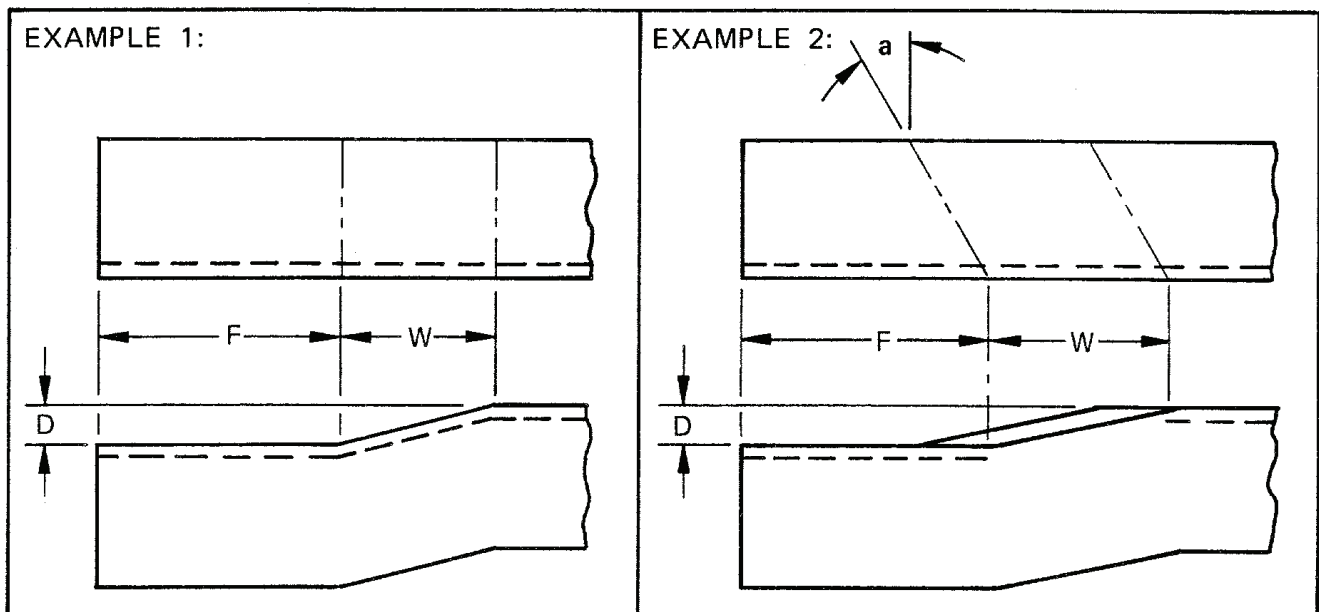

JOGGLES

FIGURE 21-9

21.7.2 Joggle Tolerances. Depending on the process(es) used, dimensions "F" and "W" should have a tolerance of not less than ± 0.03 , and dimension "D" should have a tolerance of not less than $\pm .010$. It is preferable to allow the flange to be displaced as well as the face of the part, but if this is not permissible, it may be shown as in FIGURE 21-10. In general larger tolerances are required for manually-performed operations than for CNC operations.

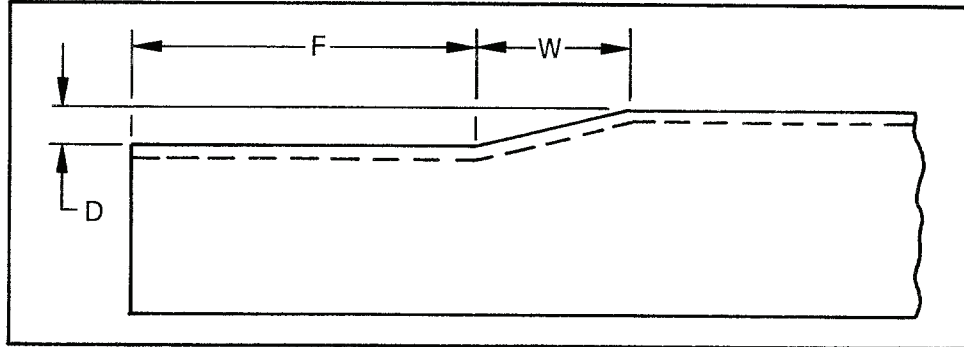

JOGGLE WITHOUT FLANGE DISPLACEMENT

FIGURE 21-10

21.7.3 Angles Other Than 90 In Joggles. When the angle in the face of the part is other than 90° to the mold line, the angle must be specified.

21.7.4 Flange Displacement In Joggles. It is preferable to allow the flange to be displaced as well as the face of the part, (see FIGURE 21-11) but if this is not permissible, it may be shown as in FIGURE 21-10.

21.7.5 Double Joggles. When both the face of a part and the flange are joggled in the same area, it is preferred to make both joggles coincide and use a washout length as determined by the deepest joggle. (See FIGURE 21-11).

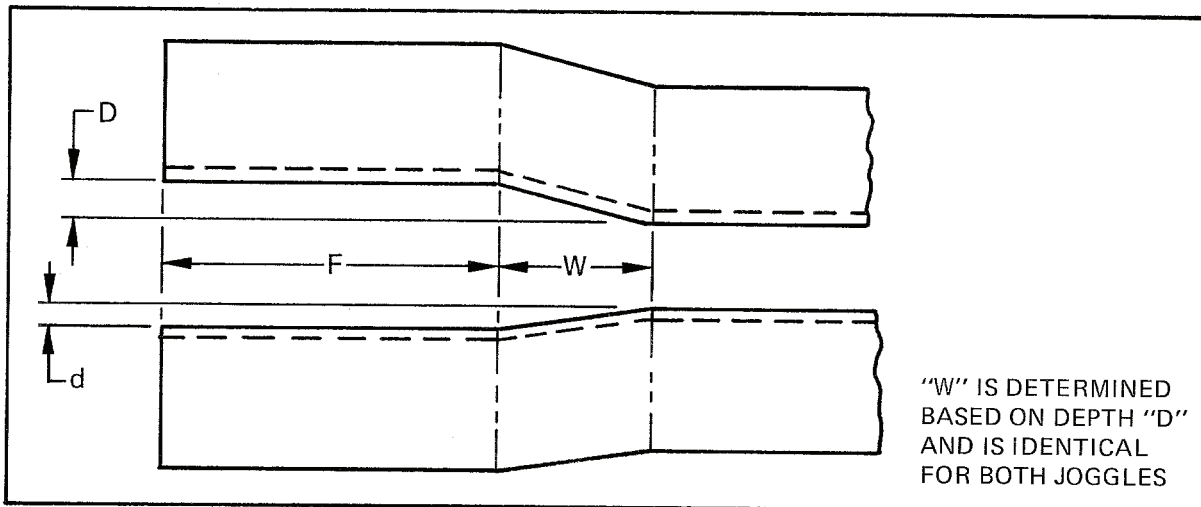

DOUBLE JOGGLE

FIGURE 21-11



21.7.6 Joggle Washout. The "W" dimension varies with different materials. It is greater for harder materials and is dependent on the depth of joggle. Joggle washout may be determined by using TABLE 21-1 and 21-2.

I N C H	THICKNESS	1010 (B=4)		1020 1095 (B=4)		4130, 4137, 4337, 8630 (B=4)				CORROSION-RESISTANT (B=4)			
						NORMALIZED		ANNEALED		ANNEALED		½ HARD	
		A	C	A	C	A	C	A	C	A	C	A	C
.016				.099	.157					.009	.157	.009	.157
.018	.009	.161		.010	.165	.017	.286			.009	.161	.017	.286
.020				.018	.300	.018	.300			.010	.165	.017	.290
.025	.010	.175		.018	.312					.010	.175	.018	.300
.031										.011	.187	.018	.312
.032	.011	.189											
.035	.019	.320		.019	.320	.034	.570			.019	.320	.026	.445
.042	.020	.334		.020	.334	.034	.584			.020	.334	.027	.459
.050	.021	.350		.028	.475	.035	.600			.021	.350	.035	.600
.063										.022	.376	.037	.626
.065	.022	.380		.030	.505	.037	.630			.022	.380	.037	.630
.078	.031	.531		.039	.656	.046	.781			.031	.531	.046	.781
.083				.039	.666	.047	.791						
.094										.033	.563	.055	.938
.095	.033	.565		.055	.940			.033	.565				
.109	.042	.718		.057	.968			.042	.718				
.125	.044	.750		.059	1.000			.044	.750	.044	.750	.074	1.250
.156	.063	1.062		.077	1.312			.055	.937				
.188	.066	1.125		.096	1.625			.066	1.125	.066	1.125		
.250	.088	1.500		.118	2.000			.088	1.500	.088	1.500		

M E T R I C	THICKNESS	1010 (B=4)		1020 1095 (B=4)		4130, 4137, 4337, 8630 (B=4)				CORROSION-RESISTANT (B=4)			
						NORMALIZED		ANNEALED		ANNEALED		½ HARD	
		A	C	A	C	A	C	A	C	A	C	A	C
0.41				0.23	3.99					0.23	3.99	0.23	3.99
0.46	0.23	4.09		0.25	4.19	0.43	7.26			0.23	4.09	0.43	7.26
0.51				0.46	7.62	0.46	7.62			0.25	4.19	0.43	7.37
0.64	0.25	4.44		0.46	7.92					0.25	4.44	0.46	7.62
0.79										0.28	4.75	0.46	7.92
0.81	0.28	4.80											
0.89	0.48	8.13		0.48	8.13	0.86	14.48			0.48	8.13	0.66	11.30
1.07	0.51	8.48		0.51	8.48	0.86	14.83			0.51	8.48	0.69	11.66
1.27	0.53	8.89		0.71	12.06	0.89	15.24			0.53	8.89	0.89	15.24
1.60										0.56	9.55	0.99	15.90
1.65	0.59	9.65		0.76	12.83	0.94	16.00			0.56	9.65	0.99	16.00
1.98	0.79	13.49		0.99	16.66	1.17	19.84			0.79	13.49	1.17	19.84
2.11				0.99	16.92	1.19	20.09						
2.39										0.84	14.30	1.40	23.82
2.41	0.84	14.35		1.40	23.88			0.84	14.35				
2.77	1.07	18.24		1.45	24.59			1.07	18.24				
3.05	1.12	19.05		1.50	25.40			1.12	19.05	1.12	19.05	1.88	31.75
3.96	1.60	26.97		1.96	33.32			1.40	23.80				
4.78	1.68	28.58		2.44	41.28			1.68	28.58	1.68	28.58		
6.35	2.24	38.10		3.00	50.80			2.24	38.10	2.24	38.10		

IF JOGGLE DEPTH IS GREATER "A"
WASHOUT = B X DEPTH

IF JOGGLE DEPTH IS LESS THAN "A"
WASHOUT = √DEPTH (C - DEPTH)

STANDARD JOGGLE WASHOUT FACTORS FOR STEEL

TABLE 21-1



I C O N	THICKNESS	2024-0 (B=3)		2024-T4 (B=4)		5052-0 6061-0 (B=3)		6061-T4 (B=4)		6061-T6 (B=4)		7075-0 (B=4)		7075-T6 (B=8)	
		A	C	A	C	A	C	A	C	A	C	A	C	A	C
		.012	.015	.149	.016	.274	.009	.152	.009	.152	.009	.152	.017	.282	.008
.016	.016	.157	.017	.282	.009	.160	.009	.160	.009	.160	.017	.290	.008	.540	
.020	.016	.165	.017	.290	.010	.168	.010	.168	.010	.168	.018	.300	.008	.550	
.025	.030	.300	.019	.300	.010	.178	.010	.178	.018	.300	.018	.300	.008	.550	
.032	.031	.314	.026	.439	.011	.192	.011	.192	.018	.314	.018	.314	.009	.564	
.040	.033	.330	.027	.455	.019	.330	.019	.330	.027	.455	.019	.330	.013	.830	
.051	.035	.352	.035	.602	.021	.352	.021	.352	.028	.477	.028	.477	.017	1.102	
.064	.050	.503	.044	.753	.022	.378	.030	.503	.037	.628	.030	.503	.021	1.378	
.072	.064	.644	.060	1.019	.023	.394	.038	.644	.045	.769	.045	.769	.025	1.644	
.081	.066	.662	.068	1.162	.032	.537	.046	.787	.054	.912	.054	.912	.030	1.912	
.091	.068	.682	.077	1.307	.033	.557	.055	.932	.062	1.057	.070	1.182	.034	2.182	
.102	.083	.892	.093	1.579	.041	.704	.063	1.079	.071	1.204	.086	1.454	.038	2.454	
.125	.100	1.000	.118	2.000	.052	.875	.074	1.250	.081	1.375	.096	1.625	.050	3.250	
.156	.131	1.312	.151	2.562	.062	1.062	.084	1.437	.099	1.687	.129	2.188	.062	4.062	
.188	.175	1.750	.221	3.750	.074	1.251	.110	1.876	.132	2.251	.155	2.625	.075	4.875	
.250	.237	2.375	.323	5.500	.096	1.625	.176	3.000	.176	3.000	.206	3.500	.100	6.500	

M E T R I C	THICKNESS	2024-0 (B=3)		2024-T4 (B=4)		5052-0 6061-0 (B=3)		6061-T4 (B=4)		6061-T6 (B=4)		7075-0 (B=4)		7075-T6 (B=8)	
		A	C	A	C	A	C	A	C	A	C	A	C	A	C
		0.30	0.38	3.78	0.41	6.96	0.23	3.86	0.23	3.86	0.23	3.86			
0.41	0.41	3.99	0.43	7.16	0.23	4.06	0.23	4.06	0.23	4.06	0.43	7.16	0.20	13.51	
0.51	0.41	4.19	0.43	7.37	0.25	4.27	0.25	4.27	0.25	4.27	0.43	7.37	0.20	13.72	
0.64	0.76	7.62	0.48	7.62	0.25	4.52	0.25	4.52	0.46	7.62	0.46	7.62	0.20	13.97	
0.81	0.79	7.98	0.66	11.15	0.28	4.88	0.28	4.88	0.46	7.98	0.46	7.98	0.23	14.33	
1.02	0.84	8.38	0.69	11.56	0.48	8.38	0.48	8.38	0.69	11.56	0.48	8.38	0.33	21.08	
1.30	0.89	8.94	0.89	15.29	0.53	8.94	0.53	8.94	0.71	12.12	0.71	12.12	0.43	27.99	
1.63	1.27	12.78	1.12	19.13	0.56	9.60	0.76	12.78	0.94	15.95	0.76	12.78	0.53	35.00	
1.83	1.63	16.36	1.52	25.88	0.58	10.01	0.96	16.36	1.14	19.53	1.14	19.53	0.64	41.76	
2.06	1.68	16.81	1.73	29.51	0.81	13.64	1.17	19.99	1.37	23.16	1.37	23.16	0.76	48.56	
2.31	1.73	17.32	1.96	33.20	0.84	14.15	1.40	23.67	1.57	26.85	1.78	30.02	0.86	55.42	
2.59	2.11	22.66	2.36	40.11	1.04	17.88	1.60	27.41	1.80	30.58	2.18	36.93	0.96	66.33	
3.18	2.54	25.40	3.00	50.80	1.32	22.22	1.88	31.75	2.06	34.92	2.44	41.28	1.27	82.55	
3.96	3.33	33.32	3.84	65.07	1.57	26.97	2.13	36.50	2.51	42.85	3.28	55.58	1.57	103.17	
4.78	4.44	44.45	5.61	95.25	1.88	31.78	2.79	47.65	3.35	57.18	3.94	66.68	1.90	123.82	
6.35	6.02	60.32	8.20	139.70	2.44	41.28	4.47	76.20	4.47	76.20	5.23	88.90	2.54	165.10	

STANDARD JOGGLE WASHOUT FACTORS FOR ALUMINUM ALLOYS

TABLE 21-2

21.8 BEADS.

21.8.1 Bead Dimensioning. Beads are raised or depressed areas in sheet metal parts, usually for the purpose of providing rigidity. It should be recognized that beads necessitate stretching the material and normally are formed into parts by using dies. The plan view shows an outline of the bead at the mold line in phantom lines. It is necessary to show sections or breakouts to dimension the bead depth and the bead radii. When there is a straight section between two bend radii, the angle must be dimensioned. FIGURE 21-12 illustrates dimensioning for a bead.

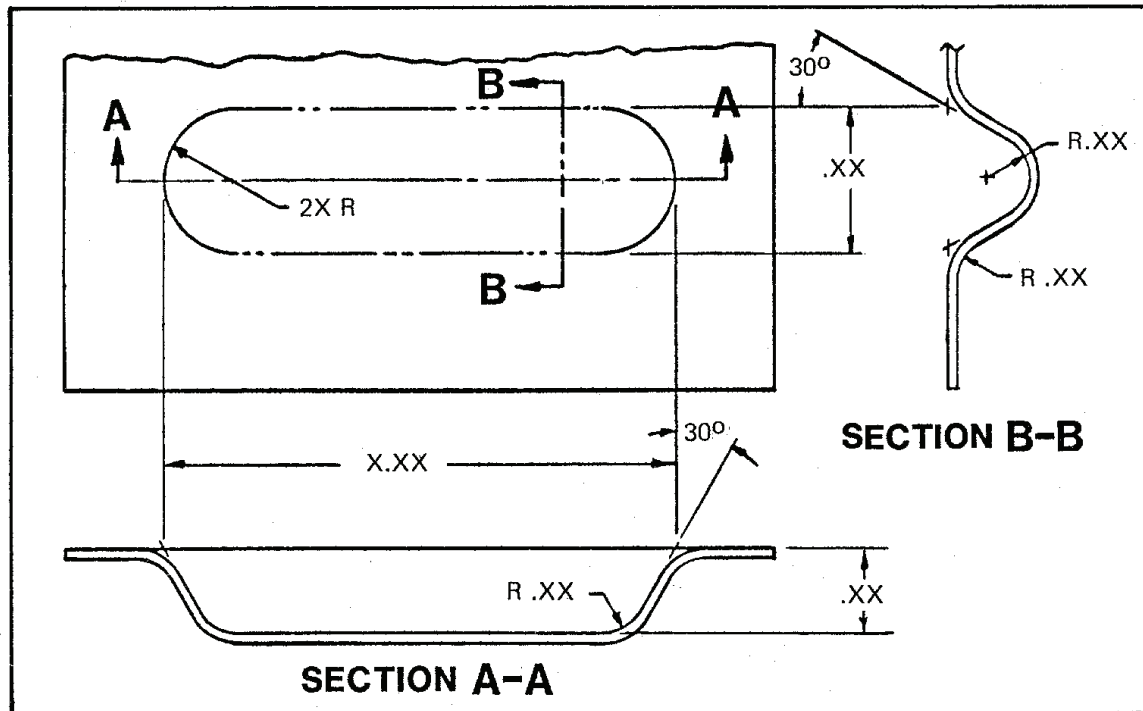

BEADS
 FIGURE 21-12

21.9 LIGHTENING HOLES.

21.9.1 Lightening Hole Dimensioning. Lightening holes are cutouts in sheet metal parts usually for the purpose of reducing weight. They may be plain round holes or of other shapes and are dimensioned in the same manner as other cutouts. If a bead is incorporated around the periphery, the bead is dimensioned as explained in PARAGRAPH 21.8, and the cutout is dimensioned to finished dimensions after forming the bead. It is not economical to specify hole size tolerances closer than $\pm .06$ on holes with beaded edges, and even larger tolerances should be specified if the hole is not circular. It should be recognized that cutouts with beaded edges require the use of dies.

21.10 DIMPLING AND COUNTERSINKING.

21.10.1 Dimpling And Countersink Hole Dimensioning. Dimpling and countersinking are the two methods used to install flat head fasteners in a flush condition. Thin materials are dimpled (See FIGURE 21-13) and thick materials are countersunk (See FIGURE 21-14). The determination whether to dimple or countersink can be made by consulting tables in MIL-STD-403 which show the minimum and maximum material thickness applicable to dimpling and the minimum for countersinking. There is some overlap between the maximum for dimpling and the minimum for countersinking, and the method used in this overlap area should be an engineering decision. All installations of flush head screws or rivets for rocket and missile structure should be prepared for 100° fasteners in accordance with the requirements of MIL-STD-403.

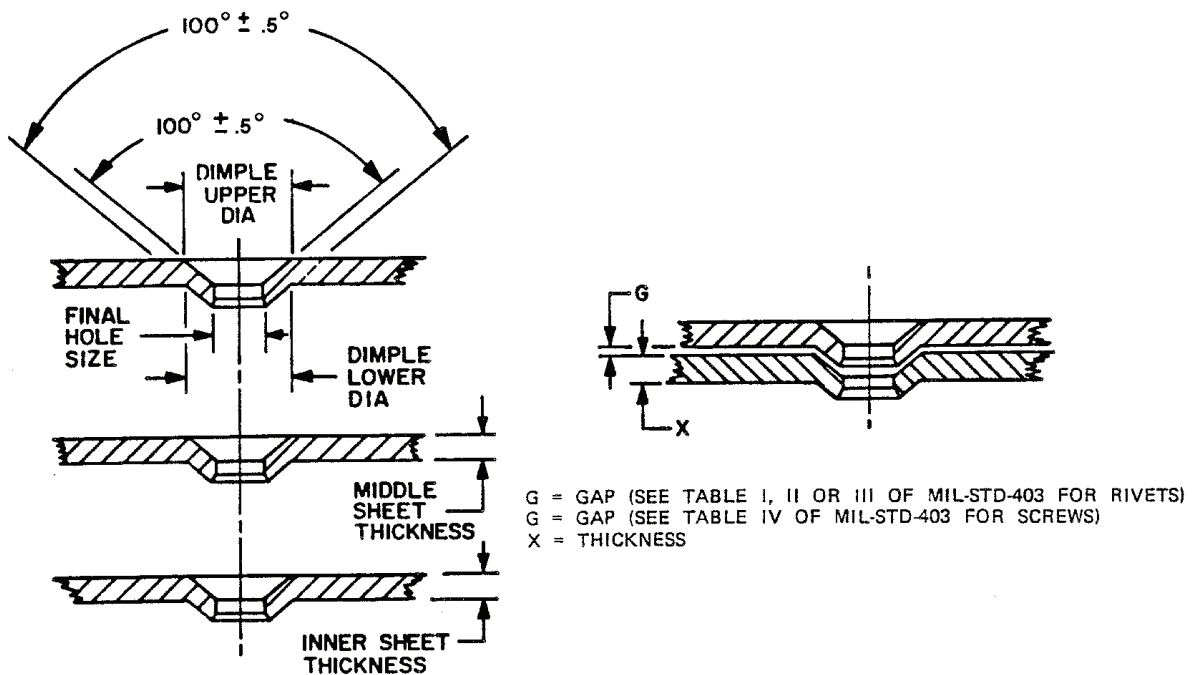

NOTES:

1. DIMPLE DIMENSIONS ARE THE SAME FOR INNER, MIDDLE AND OUTER SHEETS. SEE TABLE I, II OR III FOR RIVETS AND TABLE IV FOR SCREWS OF MIL-STD-403.
2. DIMPLE DIMENSIONS ARE CHOSEN SO THAT THE RIVET HEAD WILL BE "FLUSH" TO "HIGH" AFTER DRIVING. THIS MAY NECESSITATE SHAVING DEPENDING UPON SURFACE REQUIREMENTS.
3. DIMPLE DIMENSIONS ARE CHOSEN SO THAT THE SCREW HEAD WILL BE "FLUSH" TO "LOW" AFTER INSTALLATION.

THIN MATERIALS ARE DIMPLED FOR RIVETS AND SCREWS

FIGURE 21-13

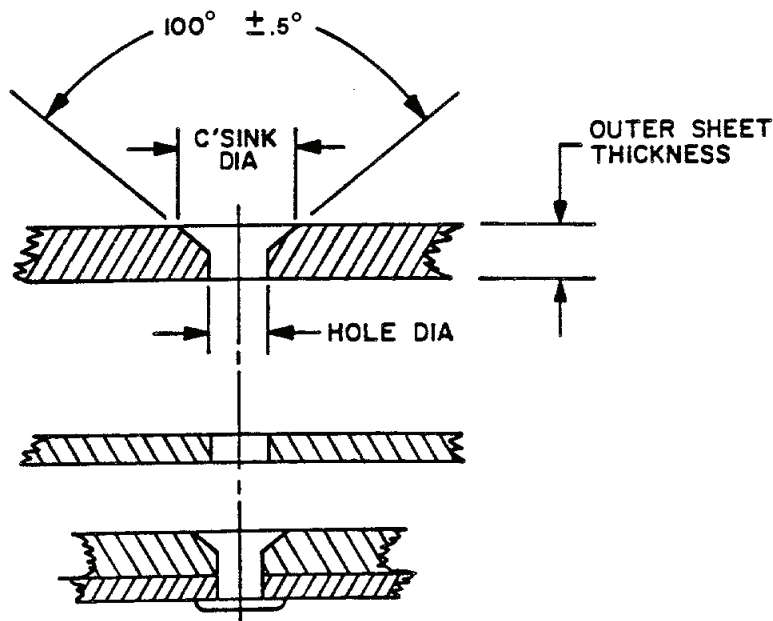

NOTES:

1. COUNTERSINK DIMENSIONS FOR RIVETS, SEE MIL-STD-403, TABLE I, II OR III.
2. COUNTERSINK DIMENSIONS ARE CHOSEN SO THAT RIVET HEAD WILL BE "FLUSH" TO "HIGH" AFTER DRIVING. THIS MAY NECESSITATE SHAVING DEPEND-UPON SURFACE REQUIREMENTS.
3. COUNTER SINK DIMENSIONS FOR SCREWS, SEE MIL-STD-403 TABLE IV.
4. COUNTERSINK DIMENSIONS ARE CHOSEN SO THAT THE SCREW HEAD WILL BE "FLUSH" TO "LOW" AFTER INSTALLATION.

THICK MATERIALS ARE COUNTERSUNK FOR RIVETS AND SCREWS

FIGURE 21-14

21.10.2 Drawing Callouts.

21.10.2.1 Method Of Matchdrilling, Dimpling And Countersinking Two Or More Sheets. When dimpling two or more sheets, or when combining a dimpled top sheet with a countersunk lower sheet, the dimple in the top sheet must nest perfectly in the dimple or countersink in the lower sheet. To achieve this fit, the sheets are matchdrilled with a pilot drill, dimpled, and then the hole is drilled to finished size. For this reason, dimples are called out only on assembly drawings where all dimpled parts are shown in their assembled position. The finished hole size only is specified. Finished hole sizes for dimpled parts are shown in MIL-STD-403. Dimples are not dimensioned but are called out as follows:



21.10.2.1 (Continued)

a. As a local note on the field of the drawing

- (1) DIMPLE FOR DIA .093 RIVET - ITEMS 1 AND 3 PER MIL-STD-403.
- (2) DIMPLE FOR DIA .250 SCREW - ITEMS 1 AND 3 PER MIL-STD-403.
- (3) DIMPLE FOR DIA .250 SCREW - ITEM 1 CSK 100°0' + 0°30' X DIA .523 – .513 - ITEM 3 PER MIL-STD-403.

b. Use of the "NAS FASTENER CODE SYSTEM". See FIGURE 21-16.

- (1) Definition of NAS Fastener Code Symbol Quadrants

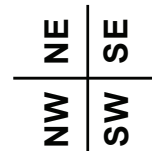
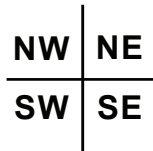

WHERE:

- NW = North West
- NE = North East
- SW = South West
- SE = South East

Symbols are oriented with the part definition on the drawing.



21.10.2.1 (Continued)

(2) Use NAS Fastener Code symbols.

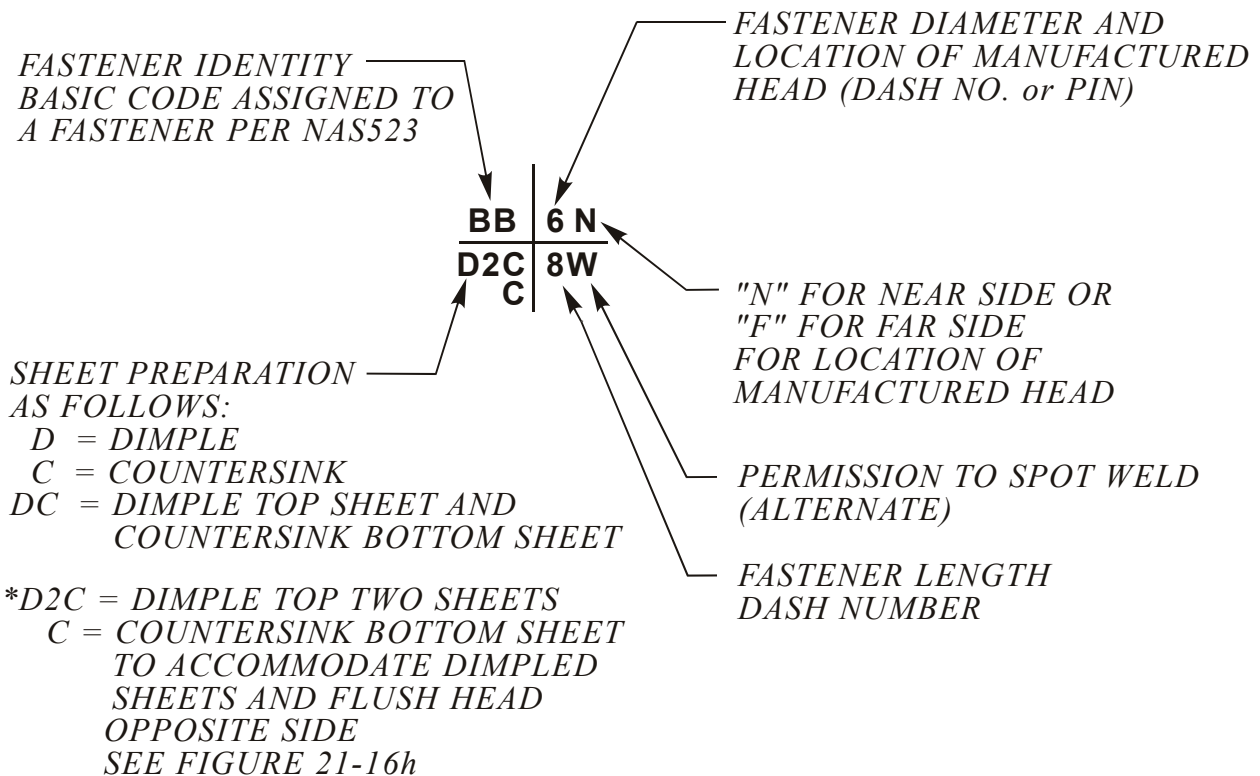

* No more than three (3) characters shall be shown on one line in the SW Quadrant. Use the top line to show sheet preparation for the manufactured head and the second line to show sheet preparation for the shop upset head. See FIGURE 21-16h.

(3) Pre-Printed forms and decals may be used on the first sheet of drawings which use the NAS Fastener Code System. A sample format is shown in FIGURE 21-17.

21.10.2.2 Plan And Sectional Views Of Dimples. Dimples are shown the same as countersinks in the plan view. In section views, dimples are shown as a depression in the metal, matching the contour of the fastener head. See FIGURE 21-15.

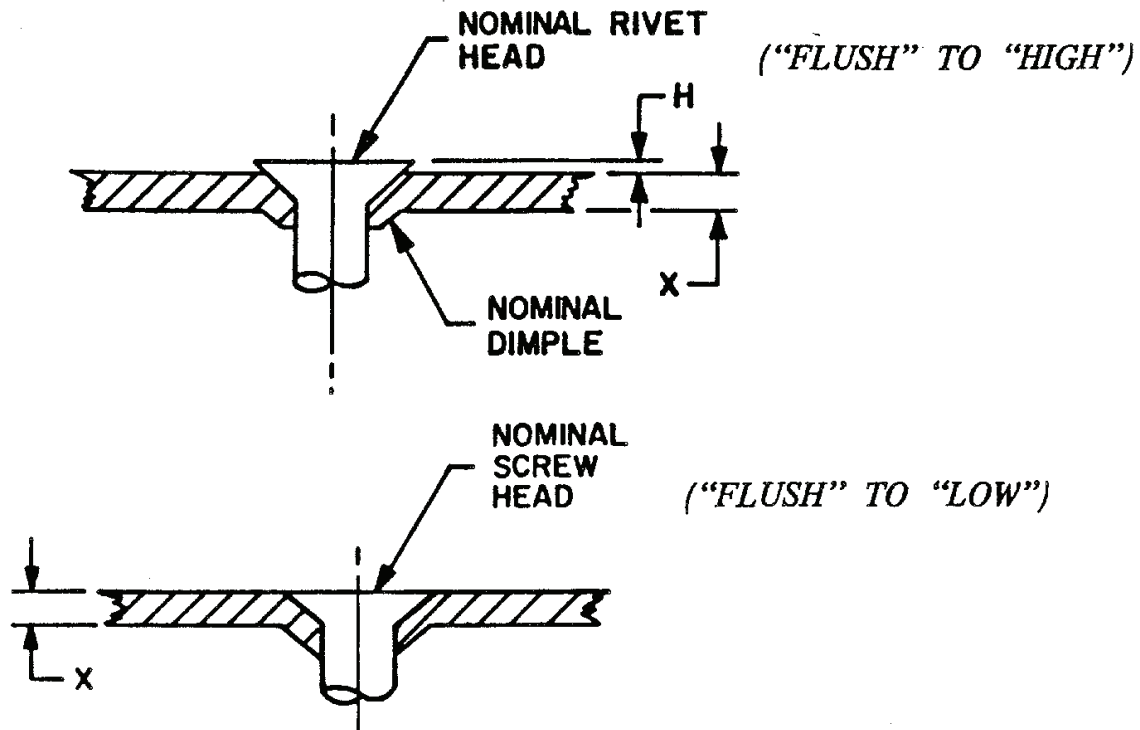

SECTIONAL VIEW OF DIMPLE WITH FASTENER

FIGURE 21-15

21.10.2.3 Countersink Dimensioning. Countersinks are shown and dimensioned as shown in SECTION 5. Dimensions for countersinks alone and countersinks used in combination with dimples are shown in MIL-STD-403.



21.10.2.4 Sheet Preparation Examples. See FIGURE 21-16a thru 21-16h.

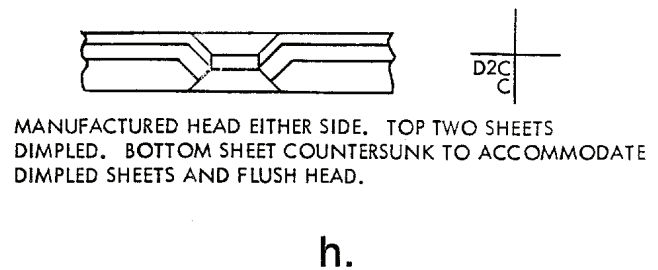
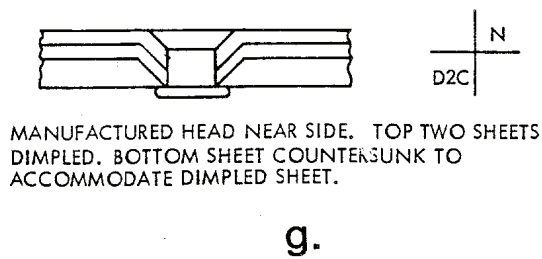
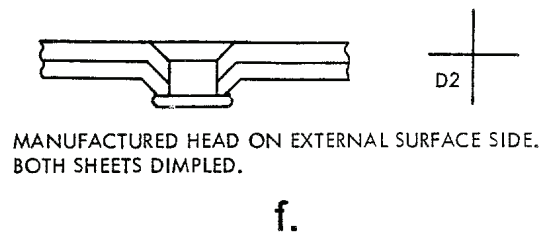
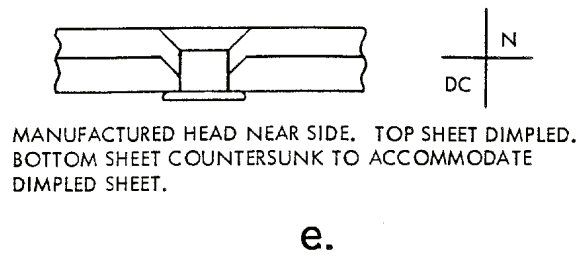
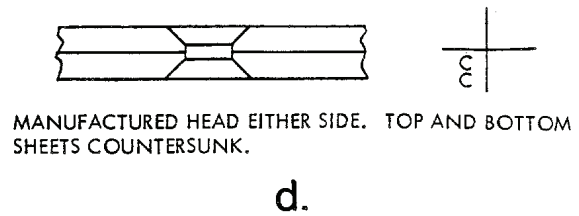
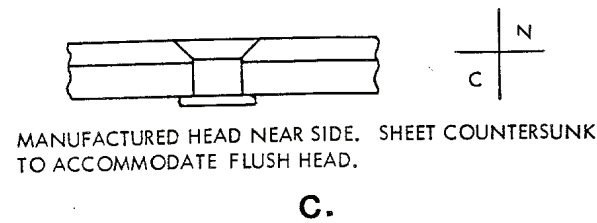
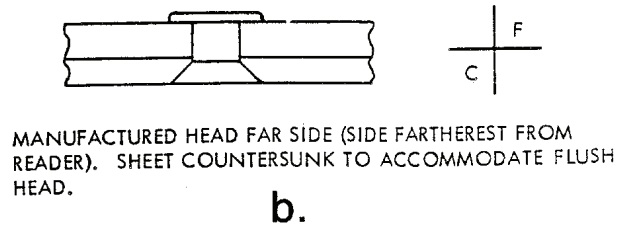
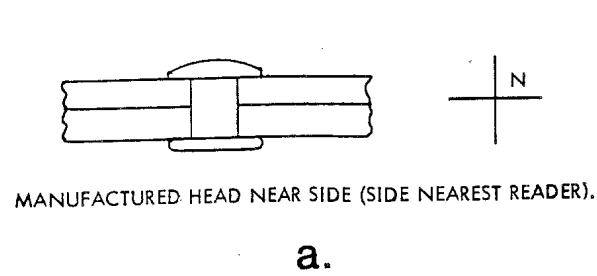

SHEET PREPARATION EXAMPLES

FIGURE 21-16



EXTEND COLUMNS AND ENTER
 ADDITIONAL NAS523 RIVET
 CODES AS REQUIRED.

OFTEN USED RIVET NOS.
 MAY BE PREPRINTED.

WHERE THE FASTENER CODE INCLUDES A
 COLLAR, LIST THE COLLAR NO. DIRECTLY
 ABOVE THE RIVET. INCLUDE THE ABBREVI-
 ATION "COL" AND A 45° ANGLE AS SHOWN.

	NAS528A COL	●	NAS1080C COL																																
KC	NAS1055	DY	NAS1424-NAS1432																																
BB	MS20426AD	BJ	MS 20470AD	LZ	NAS1097AD																														
CODE	RIVET	CODE	RIVET	CODE	RIVET																														
NAS523 RIVET CODE																																			
BASIC CODE			DIA DASH NO. AND LOCATION OF MFD HEAD																																
SHEET PREPARATION			LENGTH DASH NO.																																
D2C = DIMPLE SH 1 AND 2, CSK LWR SH			N = NEAR SIDE																																
DC = DIMPLE TOP SH, CSK LWR SH			F = FAR SIDE																																
D = DIMPLE																																			
C = CSK -- DOUBLE FLUSH HEAD																																			
C = CSK			□ = INSTL RIVET																																
<table border="1" style="width: 100%;"> <tr> <td colspan="6" style="text-align: center;">EXAMPLE:</td> </tr> <tr> <td style="text-align: center;">BB</td> <td style="text-align: center;">5</td> <td style="text-align: center;">N</td> <td colspan="3">NAS1399D5-5 RIVET</td> </tr> <tr> <td colspan="3"></td> <td colspan="3">INSTL RIVET</td> </tr> <tr> <td style="text-align: center;">D</td> <td style="text-align: center;">5</td> <td colspan="4">DIMPLE ALL SH</td> </tr> <tr> <td colspan="3"></td> <td colspan="3">INSTALL NEAR SIDE</td> </tr> </table>						EXAMPLE:						BB	5	N	NAS1399D5-5 RIVET						INSTL RIVET			D	5	DIMPLE ALL SH							INSTALL NEAR SIDE		
EXAMPLE:																																			
BB	5	N	NAS1399D5-5 RIVET																																
			INSTL RIVET																																
D	5	DIMPLE ALL SH																																	
			INSTALL NEAR SIDE																																

SAMPLE FASTENER CODE BLOCK FORMAT

FIGURE 21-17

21.11 DIMENSIONING AND TOLERANCING SHEET METAL PARTS.

21.11.1 Dimensioning And Tolerancing Parts With Straight Bends. Parts with straight bends which can be formed on a brake are dimensioned to outside mold lines and to inside bend radii. Dimensioning to inside mold lines is done only when the tolerance on the metal thickness cannot be allowed to affect the tolerance on the inside dimensions. When this condition exists, the part usually requires die forming to hold close tolerances. Larger parts to be formed on a brake should have tolerances of not less than ±.03 for bend radii and between bends. Tolerances larger than ±.03 are preferred. Smaller tolerances are possible for a dimension from a bend to the edge of the part, but trimming after forming is usually necessary in this case. FIGURE 21-18 shows acceptable methods for dimensioning brake formed parts.

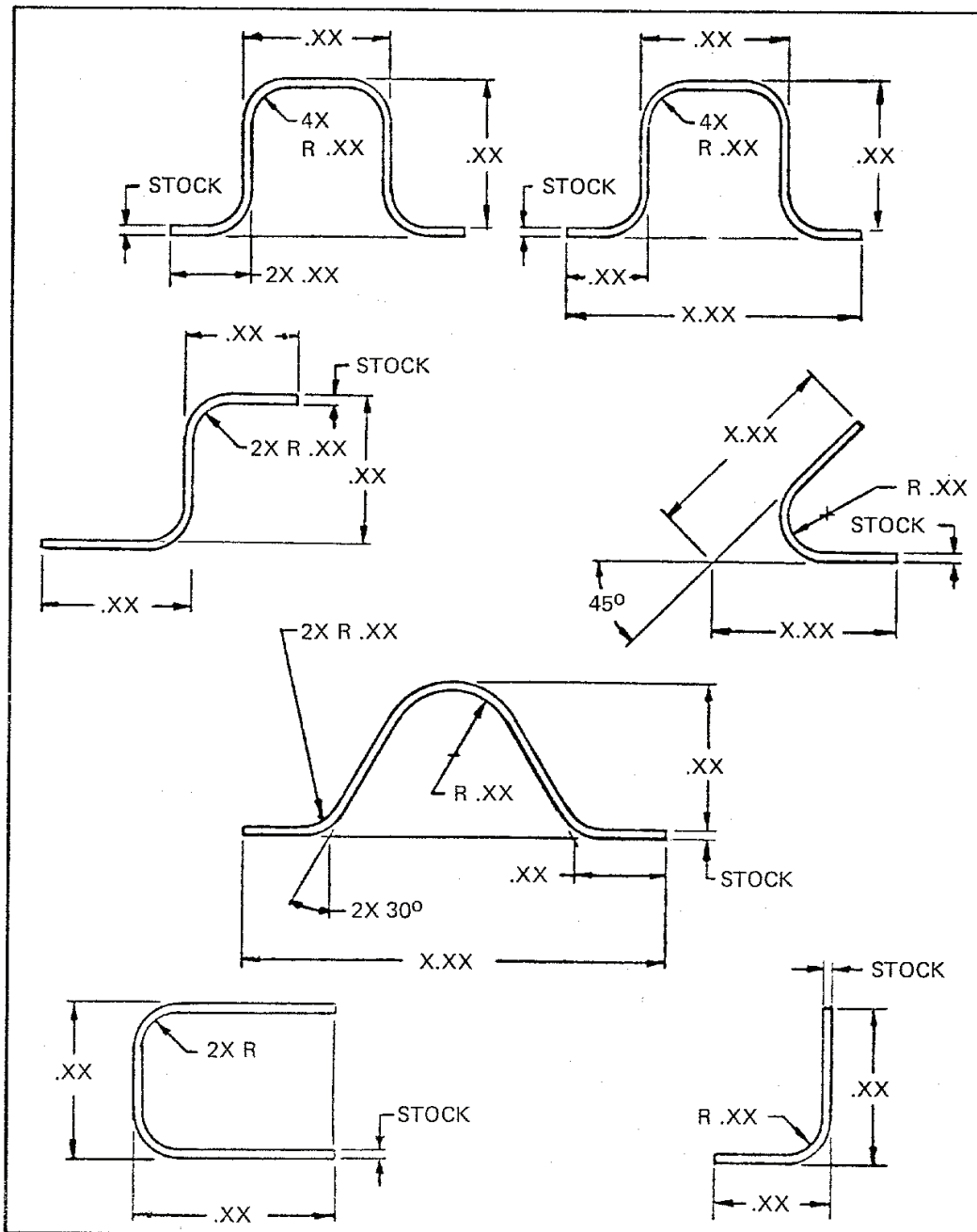

DIMENSIONING FOR BRAKE FORMING

FIGURE 21-18

21.11.2 Dimensioning And Tolerancing Drawn Parts Or Parts With Curved Bends. Parts which require stretching and/or compressing the material, as in deep drawn parts or those with bends which are not straight, are formed by means of dies or form blocks. Tolerances for larger size parts should be no less than $\pm .03$, and larger tolerances are preferred. Dimensions may be given to either inside or outside mold lines depending on design requirements, but all dimensions are given to the same side of the material. Bend radii are given to the inside of the bend. Acceptable methods of dimensioning drawn parts are shown in FIGURE 21-19.

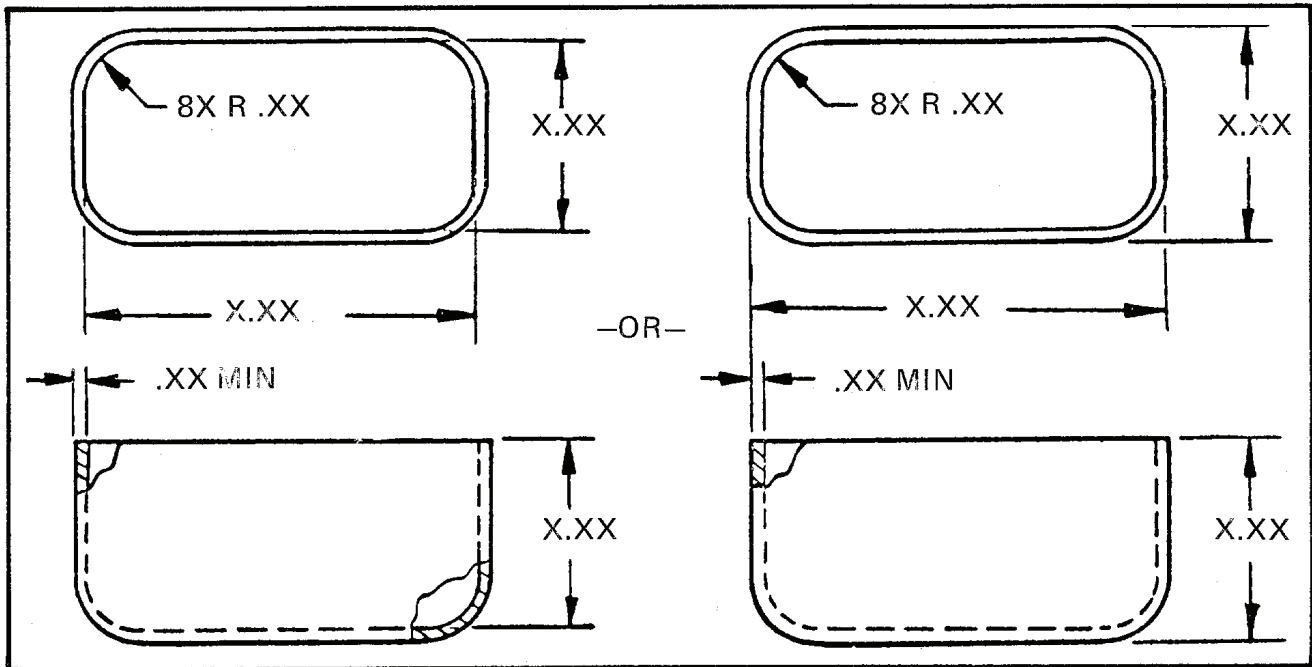

DRAWN PART DIMENSIONING

FIGURE 21-19

21.11.3 Dimensioning Spun Parts. Parts formed by spinning are dimensioned to the inside surface so that dimensions given can be used directly to make the spinning block. Small tolerances can be held with increased cost, but tolerances should be as large as the design will permit. Thickness tolerance depends on the severity of forming. It is preferred to specify thickness as the minimum acceptable limit.



21.11.3.1 Baseline Dimensioning. When it is not convenient to show dimension lines for each dimension, it is permissible to use baseline dimensions. In this method a group of dimensions are coming from zero in the "X" and "Y" direction. Zero may be applied to the edge of the part as shown in FIGURE 21-20, or zero may be applied to a single hole. Note that in the following example the zero dimension values are shown as basic dimensions, as they represent the origin of the other basic baseline dimensions. Dimensions coming from zero in the "X" direction may be rotated 90° so that they are read from the right side of the drawing as shown. This is only permitted with baseline dimensioning. If there are dimensions going in the negative direction from zero, a negative sign in front of each dimension is not needed unless there is a chance of misinterpretation.

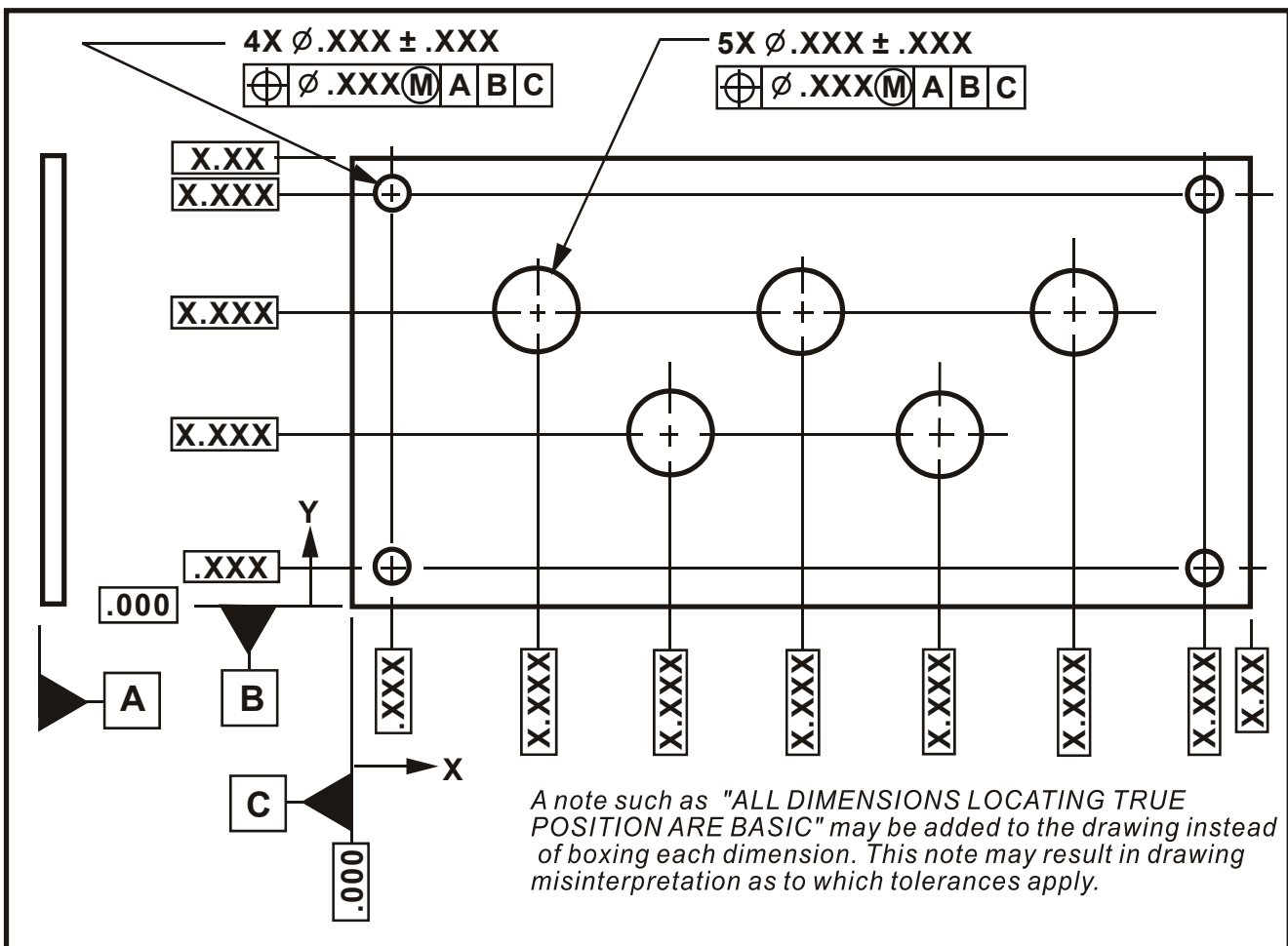

BASELINE DIMENSIONING
FIGURE 21-20

21.11.3.2 Tabular Dimensioning. When there are many holes in a part and it is not practical to use normal dimensioning methods, tabular dimensioning may be used. Datums are identified and arrowheads are used to indicate the "X" and "Y" directions. Each hole is identified with a letter and numeral. The same letter with a different numeral is assigned to all holes of identical size. A tabulation shows the hole size, number of holes, "X" and "Y" dimensions from datums and the positional tolerance for each hole. (See FIGURE 21-21.)

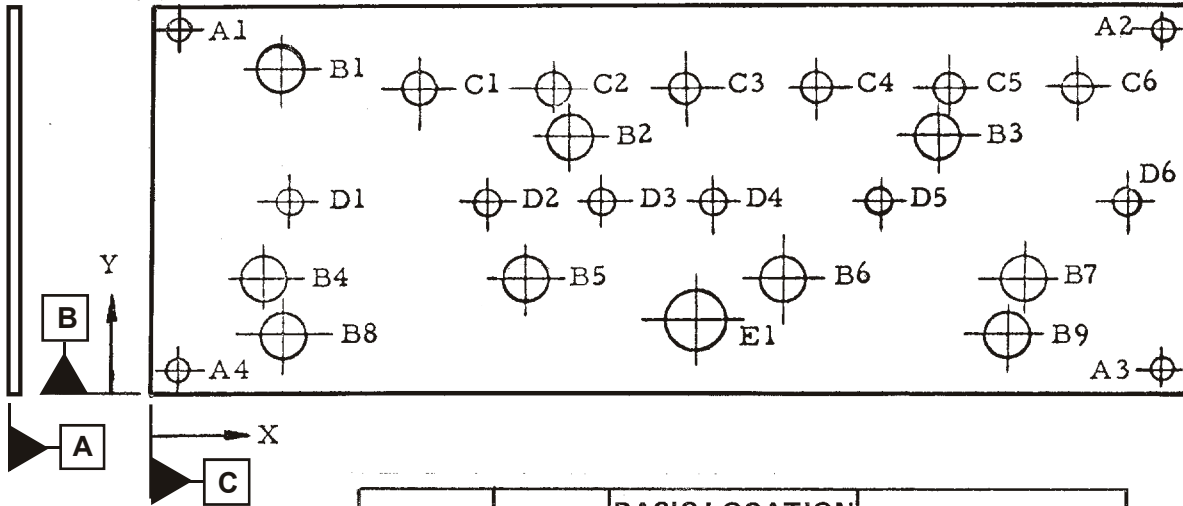

INCH	METRIC
.020	0.51
.030	0.76
.062	1.57
.121	3.07
.125	3.18
.221	5.61
.250	6.35
.281	7.14
.510	12.95
.625	15.88
.750	19.05
1.000	25.40
2.062	52.37
2.375	60.33
2.500	63.50
3.000	76.20
3.250	82.55
3.750	95.25
4.000	101.60
4.125	104.78
4.250	107.95
4.500	114.30
4.750	120.65
5.500	139.70
5.625	142.88
6.000	152.40
6.250	158.75
6.875	174.62
8.000	203.20
9.000	228.60
9.125	231.78
9.750	247.65
9.875	250.82
10.250	260.35
10.750	273.05

HOLE SYMBOL	HOLE DIA THRU	BASIC LOCATION		POSITION FEATURE CONTROL FRAME
		X →	Y ↑	
A1	.121	.250	4.750	⊕ ⌀.020 (M) A B C
A2		10.750		
A3			.250	
A4		.250		
B1	.510	.750	4.500	⊕ ⌀.125 (M) A B C
B2		4.125	3.250	
B3		9.000		
B4		.625	2.062	
B5		3.750		
B6		5.500		
B7		9.875		
B8		.750		
B9		9.750		
C1	.281	3.000	4.250	⊕ ⌀.062 (M) A B C
C2		4.500		
C3		5.625		
C4		6.875		
C5		9.125		
C6		9.750		
D1	.750	.875	2.500	⊕ ⌀.031 (M) A B C
D2		2.375		
D3		4.000		
D4		6.250		
D5		8.000		
D6		10.250		
E1	.221	6.000	1.000	⊕ ⌀.125 (M) A B C

TABULAR DIMENSIONING
 FIGURE 21-21



21.11.3.3 Pattern Of Holes. When a pattern (or group) of holes must mate with another part, it may be preferable to locate one hole in the pattern from established datums, use this hole to establish a local datum reference frame, and locate other holes in the pattern relative to this local datum reference frame. If overcrowded conditions exist in the area where this occurs or the pattern is repeated in other areas, show the local dimensioning and tolerancing in a detail view. (See Detail C in FIGURE 21-22.)

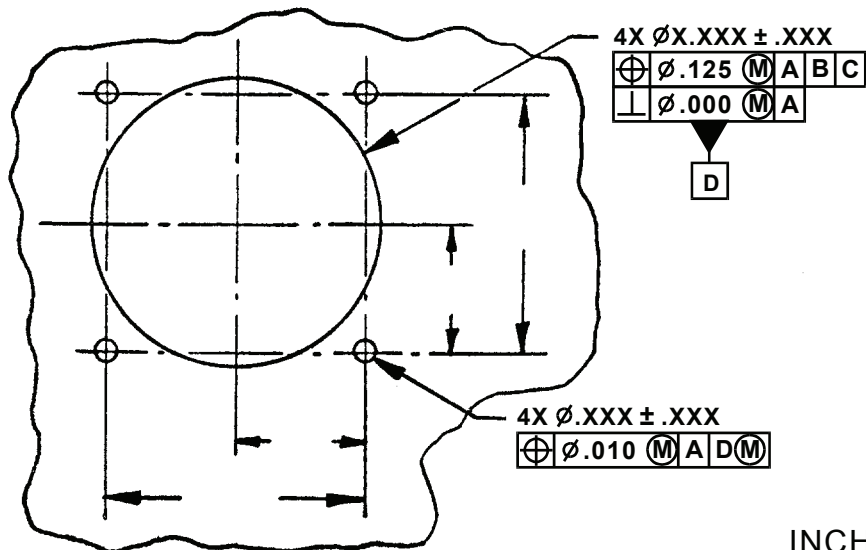
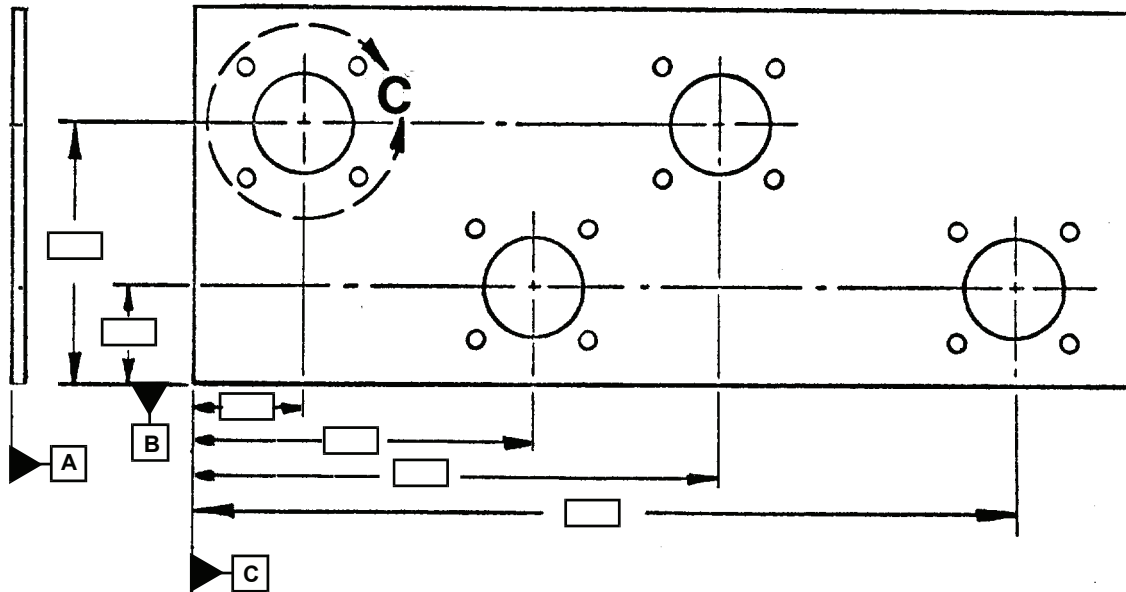

4X **DETAIL C**

INCH	METRIC
.010	.025
.125	3.175

HOLE PATTERN DIMENSIONING
FIGURE 21-22



21.12 LIMITATIONS IN FORMING SHEET METAL.

21.12.1 Minimum Flange Widths For Power Brake. Because of physical characteristics of power brakes, there are limitations on the minimum flange width that can be formed. The minimum flange widths depend on the material thickness and bend radius specified and are listed in TABLE 21-3.

21.12.2 Minimum Distance Between Bends For Power Brake. The minimum distance between bends formed by a power brake may be determined by adding the minimum flange width from TABLE 21-3 to the bend radius plus the material thickness.

		PARTS UP TO 48.00 LONG												
		BEND RADII												
GAGE	INCH	.03	.06	.09	.12	.16	.19	.22	.25	.28	.31	.38	.44	.50
		W												
.016		.080	.141	.203	.266	.328	.391	.453	.516	.578	.641			
.020		.091	.145	.207	.270	.332	.395	.457	.520	.582	.645	.770		
.025		.107	.150	.212	.275	.337	.400	.462	.525	.587	.651	.775	.900	1.025
.032		.128	.158	.219	.282	.344	.407	.469	.532	.594	.657	.782	.907	1.032
.040		.152	.182	.227	.290	.352	.415	.477	.540	.602	.665	.790	.915	1.040
.051			.215	.246	.301	.363	.426	.488	.551	.613	.676	.801	.926	1.051
.064				.285	.316	.376	.439	.501	.564	.626	.689	.814	.939	1.064
.072				.309	.340	.384	.447	.509	.572	.634	.697	.822	.947	1.072
.081					.367	.398	.456	.518	.581	.643	.706	.831	.957	1.081
.091					.397	.428	.466	.528	.591	.653	.716	.841	.966	1.091
.102						.462	.493	.539	.602	.664	.727	.852	.977	1.102
.125							.562	.593	.625	.687	.750	.875	1.000	1.125
.156									.717	.749	.781	.906	1.031	1.156
.188											.876	.938	1.063	1.188
.250												1.125	1.188	1.250

		PARTS UP TO 1219.2 LONG												
		BEND RADII												
GAGE	METRIC	0.8	1.5	2.3	3.0	4.1	4.8	5.6	6.4	7.1	7.9	9.6	11.2	12.7
		W												
0.41		2.03	3.58	5.16	6.76	8.33	9.93	11.51	13.11	14.68	16.28			
0.51		2.31	3.68	5.26	6.86	8.43	10.03	11.61	13.21	14.78	16.38	19.56		
0.64		2.72	3.81	5.38	6.98	8.56	10.16	11.73	13.34	14.91	16.54	19.68	22.86	26.04
0.81		3.25	4.01	5.56	7.16	8.74	10.34	11.91	13.51	15.09	16.69	19.86	23.04	26.21
1.02		3.86	4.62	5.77	7.37	8.94	10.54	12.12	13.72	15.29	16.89	20.07	23.24	26.42
1.30			5.46	6.25	7.65	9.22	10.82	12.40	14.00	15.57	17.17	20.35	23.52	26.70
1.63				7.24	8.03	9.55	11.15	12.73	14.33	15.90	17.50	20.68	23.85	27.03
1.83				7.85	8.64	9.75	11.35	12.93	14.53	16.10	17.70	20.88	24.05	27.23
2.06					9.32	10.11	11.58	13.16	14.76	16.33	17.93	21.11	24.31	27.46
2.31					10.08	10.87	11.84	13.41	15.01	16.59	18.19	21.36	24.54	27.71
2.59						11.73	12.52	13.69	15.29	16.87	18.47	21.64	24.82	27.99
3.18							14.27	15.06	15.88	17.45	19.05	22.22	25.40	28.58
3.96									18.21	19.02	19.84	23.01	26.19	29.36
4.78											22.25	23.83	27.00	30.18
6.35												28.58	30.18	31.75

MINIMUM DISTANCE BETWEEN BENDS (L) FORMED ON POWER BRAKE

		INCH	METRIC
EXAMPLE:	T (THICKNESS)	= .051	= 1.30
	R (BEND RADIUS)	= .25	= 6.35
	W (MIN) FROM TABLE 21-3	= .55	= 13.97
	L (MIN)	= W + R + T	= W + R + T
		= .55 + .25 + .05	= 13.97 + 6.35 + 1.27
		= .85	= 21.59

MINIMUM FLANGE WIDTHS FORMED ON POWER BRAKE

TABLE 21-3



21.12.3 Minimum Bend Radius. Refer to TABLE 21-4 through 21-8 for the minimum bend radius to be used for any specific material and material thickness. Whenever possible, use larger radii than the minimum values shown. Use the same bend radius for all bends in a part to avoid additional setup time for fabrication.

Material	Minimum Bend Radius t = Material Thickness
Commercial Brass, Soft	2t
Commercial Brass, 1/2 hard	3.5t
Copper, Soft	2t
Copper, Hard	11t
Beryllium Copper, Annealed	2t
Beryllium Copper, 1/4 Hard	4t
Beryllium Copper, 1/2 Hard	8t
Beryllium Copper, Hard	15t
Phosphor Bronze, Spring	25t

RECOMMENDED MINIMUM BEND RADII
BRASS, COPPER AND BRONZE
 TABLE 21-4

INCH	METRIC
.016	0.41
.031	0.79
.125	1.57
.188	3.18
.250	4.78
.375	6.35
.500	12.70

ALLOY	TEMPER	RADII FOR VARIOUS THICKNESSES EXPRESSED IN TERMS OF THICKNESS							
		"T" .016	.032	.062	.125	.188	.250	.375	.500
1100	-0	0	0	0	0	0	0	0	1t-2t
	-H12	0	0	0	0	0-1t	0-1t	0-1t	1t-3t
	-H14	0	0	0	0	0-1t	0-1t	0-1t	2t-3t
	-H16	0	0	0-1t	.5t-1.3t	1t-2t	1.5t-3t	2.5t-3.5t	3t-4t
	-H18	0-1t	.5t-1.5t	1t-2t	1.5t-3t	2t-4t	2t-4t	3t-5t	3t-6t
ALCLAD 2024	-0	0	0	0	0	0-1t	0-1t	1.5t-3t	3t-5t
	-T3	1t-2t	1.5t-3t	2t-4t	3t-5t	4t-6t	4t-6t	5t-7t	5.5t-8t
	-T4	1t-2t-3t	2t-4t	3t-5t	4t-6t	4t-6t	5t-7t	5.5t-8t	
	-T6	2t-4t	3t-5t	3t-5t	4t-6t	5t-7t	6t-10t	7t-10t	8t-11t
2024	-0 2/	0	0	0	0	0-1t	0-1t	1.5t-3t	3t-5t
	-T3 2/3/	1.5t-3t	2t-4t	3t-5t	4t-6t	4t-6t	5t-7t	6t-8t	6t-9t
	-T36 2/	2t-4t	3t-5t	4t-6t	5t-7t	5t-7t	6t-10t	7t-10t	8t-11t
	-T4 2/	1.5t-3t	2t-4t	3t-5t	4t-6t	4t-6t	5t-7t	6t-8t	6t-9t
	-2t-5t	4.5t-6t	5t-7t	6.5t-8t	7t-9t	8t-10t	9t-11t	9t-12t	
	-T86	4t-5.5t	5t-7t	6t-8t	7t-10t	8t-11t	9t-11t	10t-13t	10t-13t
3003	-0	0	0	0	0	0	0	0	1t-2t
	-H12	0	0	0	0	0-1t	0-1t	0-1t	1t-3t
	-H14	0	0	0	0-1t	0-1t	.5t-1.5t	1t-2.5t	1.5t-3t
	-H16	0-1t	0-1t	.5t-1.5t	1t-2t	1.5t-3t	2t-4t	2.5t-4t	3t-5t
	-H18	.5t-1.5t	1t-2t	1.5t-3t	2t-4t	3t-5t	4t-6t	4t-7t	5t-8t
3004	-0	0	0	0	0	0-1t	0-1t	.5t-1.5t	1t-2t
	-H32	0	0	0	0-1t	0-1t	.5t-1.5t	1t-2t	1.5t-2.5t
	-H34	0	0	0-1t	.5t-1.5t	1t-2t	1.5t-3t	2t-3t	2.5t-3.5t
	-H36	0-1t	.5t-1.5t	1t-2t	1.5t-3t	2t-4t	2t-4t	2.5t-5t	3t-5.5t
	-H38	.5t-1.5t	1t-2t	1.5t-3t	2t-4t	3t-5t	4t-6t	4t-7t	5t-8t

APPROXIMATE BEND RADII FOR 90 DEGREE COLD BEND ALUMINUM ALLOYS

TABLE 21-5 (Continued on next page)



TABLE 21-5
(Continued)

ALLOY	TEMPER	RADIИ FOR VARIOUS THICKNESSES EXPRESSED IN TERMS OF THICKNESS							
		.016	.031	.062	.125	.188	.250	.375	.500
5005	-0	0	0	0	0	0	0	0	1t-2t
	-H12	0	0	0	0	0	0	0	1t-3t
	-H14	0	0	0	0-1t	0-1t	.5t-1.5t	1t-2.5t	1.5t-3t
	-H16	0-1t	0-1t	.5t-1.5t	1t-2t	1.5t-3t	2t-4t	2.5t-4t	3t-5t
	-H18	.5t-1.5t	1t-2t	1.5t-3t	2t-4t	3t-5t	4t-6t	4t-7t	5t-8t
	-H32	0	0	0	0	0-1t	0-1t	0-1t	1t-3t
	-H34	0	0	0	0-1t	0-1t	.5t-1.5t	1t-2.5t	1.5t-3t
	-H36	0-1t	0-1t	.5t-1.5t	1t-2t	1.5t-3t	2t-4t	2.5t-4t	3t-5t
	-H38	.5t-1.5t	1t-2t	1.5t-3t	2t-4t	3t-5t	4t-6t	4t-7t	5t-8t
5050	-0	0	0	0	0	0	—	—	—
	-H32	0	0	0	0	0-1t	.5t-1.5t	2t-3.5t	2.5t-4t
	-H34	0	0	0	0-1t	.5t-1.5t	1t-2t	2t-4t	3t-4t
	-H36	0-1t	0-1t	.5t-1.5t	1t-2t	1.5t-3t	2t-4t	2.5t-4t	3t-5t
	-H38	.5t-1.5t	1t-2t	1.5t-3t	2t-4t	3t-5t	4t-6t	4t-7t	5t-8t
5052	-0	0	0	0	0	0-1t	.5t-1.5t	1t-2t	1.5t-2.5t
	-H32	0	0	0	0-1t	0-1t	.5t-1.5t	1t-2t	1.5t-2.5t
	-H34	0	0	0-1t	.5t-1.5t	1t-2t	1.5t-3t	2t-3t	2.5t-3.5t
	-H36	0-1t	.5t-1.5t	1t-2t	1.5t-3t	2t-4t	2t-4t	2.5t-5t	3t-5.5t
	-H38	.5t-1.5t	1t-2t	1.5t-3t	2t-4t	3t-5t	4t-6t	4t-7t	5t-8t
5083	-0	—	—	0-5t	0-1t	0-1t	.5t-1.5t	1.5t-2t	1.5t-2.5t
5086	-0	0	0	0	0-1t	0-1t	.5t-1t	.5t-1t	.5t-1.5t
	-H32	0-5t	0-1t	.5t-1.5t	1t-2t	1.5t-2t	1.5t-2.5t	2t-2.5t	2.5t-3t
	-H34	0-1t	.5t-1.5t	1t-1.5t	1.5t-2.5t	2t-3t	2t-3t	2.5t-3.5t	3t-4t
	-H36	—	—	—	2t-3.5t	2.5t-4t	3t-4.5t	3t-5t	3.5t-5.5t
	-H112	0-5t	0-5t	.5t-1t	.5t-1.5t	1t-1.5t	1t-2t	1t-2t	1.5t-2.5t
5154	-0	0	0	0	0-1t	0-1t	.5t-1.5t	.5t-1.5t	1t-2t
	-H32	0	0	0-1t	.5t-1.5t	1t-2t	1.5t-3t	2t-4t	2.5t-5t
	-H34	0-1t	0-1t	.5t-1.5t	1t-2t	1.5t-3t	2t-4t	2.5t-4.5t	3t-5t
	-H36	0-1t	.5t-1.5t	1t-2t	1.5t-3t	2t-4t	2t-4t	2.5t-5t	3t-6t
	-H38	1t-2t	1.5t-3t	2t-4t	3t-5t	4t-6t	4t-6t	5t-8t	5t-8t
	-H112	—	—	—	—	—	1.5t-3t	2.5t-4t	3t-5t
	-H321	—	—	—	0-1t	.5t-1t	.5t-1t	.5t-1.5t	.5t-2t
-H323	—	—	1t-2t	1.5t-3t	1.5t-3.5t	2t-4t	—	—	
-H343	—	—	1t-2t	1.5t-3t	2t-4t	2.5t-4.5t	—	—	
5457	-0	0	0	0	0	0	0	0	1t-2t
	-H38	.5t-1.5t	1t-2t	1.5t-3t	2t-4t	3t-5t	4t-6t	4t-7t	5t-8t
6061	-0	0	0	0	0	0-1t	0-1t	.5t-2t	1t-2.5t
	-T4 <u>2/</u>	0-1t	0-1t	.5t-1.5t	1t-2t	1.5t-3t	2t-4t	2.5t-4t	3t-5t
	-T6 <u>2/</u>	0-1t	.5t-1.5t	1t-2t	1.5t-3t	2t-4t	3t-4t	3.5t-5.5t	4t-6t
7075	-0	0	0	0-1t	.5t-1.5t	1t-2t	1.5t-3t	2.5t-4t	3t-5t
	-T6 <u>2/</u>	2t-4t	3t-5t	4t-7t	5t-7t	6t-10t	7t-11t	7t-11t	7t-12t
7079	-0	0	0	0-1t	.5t-1.5t	1t-2t	1.5t-3t	2.5t-4t	3t-5t
	-T6 <u>2/</u>	2t-4t	3t-5t	4t-6t	5t-7t	5t-7t	6t-10t	7t-11t	7t-12t
7178	-0	0	0	0-1t	.5t-1.5t	1t-2t	1.5t-3t	2.5t-4t	3t-5t
	-T6 <u>2/</u>	2t-4t	3t-5t	4t-6t	5t-7t	5t-7t	6t-10t	7t-11t	7t-12t

1/ MINIMUM PERMISSIBLE RADIUS OVER WHICH SHEET MAY BE BENT VARIES WITH NATURE OF FORMING OPERATION, TYPE OF FORMING EQUIPMENT, DESIGN AND CONDITION OF TOOLS. MINIMUM WORKING RADIUS FOR A GIVEN MATERIAL OR HARDEST ALLOY AND TEMPER FOR A GIVEN RADIUS CAN BE ASCERTAINED ONLY BY ACTUAL TRIAL UNDER CONTEMPLATED CONDITIONS OF FABRICATION.

2/ ALCLAD SHEET CAN BE BENT OVER SLIGHTLY SMALLER RADIИ THAN THE CORRESPONDING TEMPERS OF THE UNCOATED ALLOY.

3/ IMMEDIATELY AFTER QUENCHING, THIS ALLOY CAN BE FORMED OVER APPRECIABLY SMALLER RADIИ.

INCH	METRIC
.016	0.41
.031	0.79
.125	1.57
.188	3.18
.250	4.78
.375	6.35
.500	12.70

APPROXIMATE BEND RADIИ FOR 90 DEGREE COLD BEND ALUMINUM ALLOYS

TABLE 21-5 (Continued from previous page)



T (THICKNESS)		19-9DI & 17-7PH 18-8, ANNEALED STABILIZED AND UNSTABILIZED		18-8, 1/4 H		18-8, 1/2 H		18-8, HARD			
INCH	METRIC	INCH	METRIC	INCH	METRIC	INCH	METRIC	INCH	METRIC		
.010	0.25	.03	0.8	.03	0.8	.03	0.8	.09	2.3		
.012	0.30										
.016	0.41										
.018	0.46										
.020	0.51										
.022	0.56			.06	1.5	.06	1.5	.12	3.0		
.025	0.64										
.028	0.71										
.032	0.81										
.036	0.91										
.040	1.02	.06	1.5	.06	1.5	.09	2.3	.16	4.1		
.045	1.14										
.050	1.27										
.063	1.60										
.071	1.80										
.080	2.03			.09	2.3	.09	2.3	.12	3.0	.25	6.4
.090	2.29										
.100	2.54										
.112	2.84										
.125	3.18										
.160	4.06	.12	3.0	.12	3.0	.16	4.1	.31	7.9		
.188	4.78										
.250	6.35										
		.16	4.1	.16	4.1	.19	4.8	.38	9.7		
		.19	4.8	.19	4.8	.22	5.6	.41	10.4		
		.25	6.4	.25	6.4	.28	7.1	.47	11.9		
		.31	7.9	.31	7.9	.38	9.7	.50	12.7		
		.38	9.7	.38	9.7	.44	11.2	.56	14.2		
		.50	12.7	.50	12.7	.59	15.0	.62	15.7		
		.59	15.0	.59	15.0	.78	19.8	.78	19.8		
		.94	23.9	.94	23.9	1.25	31.8	1.25	31.8		

RECOMMENDED MINIMUM BEND RADII
CORROSION RESISTANT ALLOYS
 TABLE 21-6



T (THICKNESS)		SAE		ALLOYS	
		950 1010	1020 1025	4130 COND N	
INCH	METRIC	INCH	METRIC	INCH	METRIC
.020	0.51	.06	1.5	.06	1.5
.025	0.64	.06	1.5	.06	1.5
.032	0.81	.06	1.5	.09	2.3
.036	0.91	.06	1.5	.09	2.3
.040	1.02	.06	1.5	.12	3.0
.050	1.27	.09	2.3	.12	3.0
.063	1.60	.12	3.0	.16	4.1
.080	2.03	.16	4.1	.22	5.6
.090	2.29	.19	4.8	.25	6.4
.112	2.84	.22	5.6	.28	7.1
.125	3.18	.25	6.4	.31	7.9
.160	4.06	.31	7.9	.41	10.4
.188	4.78	.38	9.7	.47	11.9
.250	6.35	.50	12.7	.62	15.7
.375	9.52	.75	19.0	.94	23.9

RECOMMENDED MINIMUM BEND RADII
STEEL AND STEEL ALLOYS

TABLE 21-7

T (THICKNESS)		FS1-0 AMS 52S-0		FS1-H24 AMS 52S-H24	
		INCH	METRIC	INCH	METRIC
.012	0.30	.06	1.5	.12	3.0
.016	0.41	.09	2.3	.16	4.1
.020	0.51	.09	2.3	.19	4.8
.025	0.64	.12	3.0	.25	6.4
.032	0.81	.16	4.1	.31	7.9
.040	1.02	.19	4.8	.41	10.4
.050	1.27	.25	6.4	.50	12.7
.063	1.60	.31	7.9	.66	16.8
.071	1.80	.38	9.7	.75	19.0
.080	2.03	.41	10.4	.81	20.6
.090	2.29	.47	11.9	.91	23.1
.100	2.54	.50	12.7	1.03	26.2
.125	3.18	.62	15.7	1.25	31.8
.160	4.06	.78	19.8	1.56	39.6
.188	4.78	.94	23.9	1.88	47.8
.250	6.35	1.25	31.8	2.50	63.5
.375	9.52	1.88	47.8	3.75	95.2
.500	12.70	2.50	63.5	5.00	127.0

RECOMMENDED MINIMUM BEND RADII
MAGNESIUM ALLOYS

AT 70° F (ROOM TEMPERATURE)

TABLE 21-8



21.12.4 Tooling Or Pin Holes. When tooling holes or pin holes are required, the drawing shall contain one of the following notes:

i.e.  TOOLING HOLES PERMISSIBLE, LOCATION OPTIONAL.

OR: As a local note on the field of the drawing.

i.e. TOOLING HOLES PERMISSIBLE THIS SURFACE ONLY. 

21.13 UNDIMENSIONED DRAWINGS.

21.13.1 Undimensioned Drawing Description. An undimensioned drawing shows, to precise full scale, on environmentally stable material, a part or assembly of parts.

21.13.2 Uses And Advantages. This type of drawing may be used for any kind of part, but has been most successfully applied to assembly drawings containing a large percentage of sheet metal and extruded parts which are joined with rivets or screws. The most significant advantages gained by using undimensioned drawings are:

- a. Holes for joining parts are automatically coordinated for all parts being joined.
- b. The drawing provides all template information so that no intermediate step is necessary to lay out templates.
- c. Clearances, edge distances and interferences show more clearly, reducing the number of changes after release.

21.13.3 Drawing Requirements. The assembly is shown with all detail parts correctly located and drawn in the finished form to an accuracy of $\pm .005$ inch. The flanges of all sheet metal parts are then unfolded in flat pattern, using phantom lines, to the same accuracy. If parts are to be formed on form blocks, the form block line (FBL) is shown. All information required to make the necessary fabrication templates is shown, including location of rivet, screw or tooling holes, direction and angle of bends, bend radii and cutouts. (See FIGURE 21-23.)

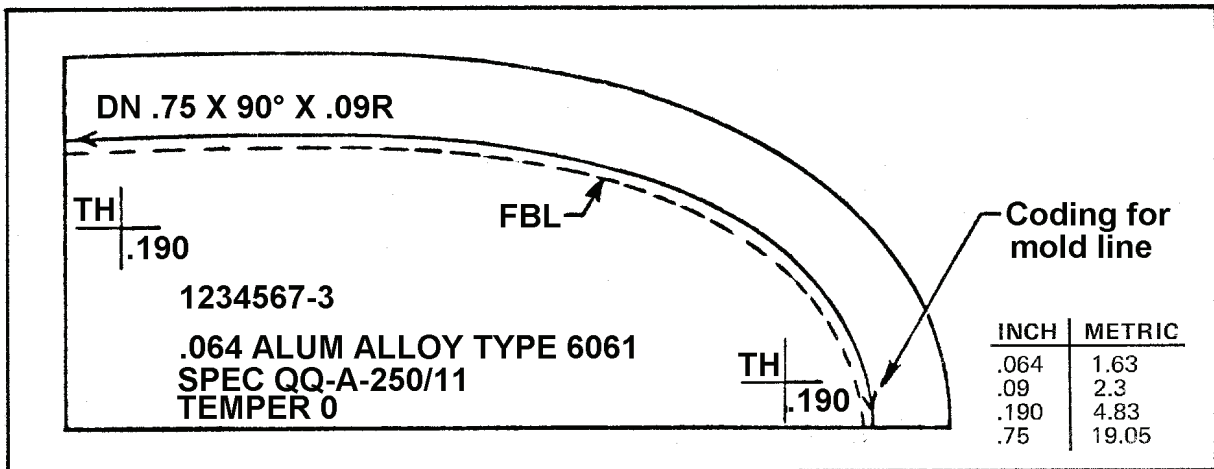

FORMING INFORMATION

FIGURE 21-23

21.13.2.1 Holes. Rivet holes are shown as intersecting center lines and coded in accordance with NAS523. Screw holes are shown as circles with crossing center lines and are called out with a leader line. Tool holes are shown as crossing center lines with the letters "TH" in the upper left hand quadrant and the diameter in decimals in the lower right hand quadrant.

21.13.2.2 Forming Information. In a flat pattern drawing, the direction of bend (up or down), the width of the flange, the bend angle and the bend radius are shown in the flange flat pattern. The mold line is coded and, if a form block line (FBL) is shown, identified. (See FIGURE 21-23.)

21.13.3.3 Cutouts. Cutouts are drawn to an accuracy of $\pm .005$ inch, with the note "CUTOUT IN (Part No.);" placed in the cutout area. If necessary for clarity, arrowheads are shown with leaders from the note to points on the periphery of the cutout.

21.14 Using 3D Solid Model Data for Sheet Metal Applications. 3D solid model data may be used similarly to an undimensioned drawing to represent the nominal or as-intended geometry for sheet metal applications. Refer to SECTION 26 in this manual for more information on using 3D solid model data as part of a design package or technical data package.



NOTES: